



SPEED SLEEVE CP 653

Product description

- Re-penetrable cable management device for electrical and telecom professionals

Product features

- Fast installation
- Easy penetration and re-penetration
- industry’s best “Air Movement” ratings
- Low L-ratings
- Withstands the rigors of usage and time
- Can be installed in wall and floor applications
- Buy American Compliant
- May be “ganged” together

Areas of application

- Cable and cable bundles

For use with

- Concrete floor rated up to 3 hours
- Gypsum walls rated up to 4 hours

Examples

- Electrical wiring
- Premise wiring
- Low voltage and datacom

Installation instructions

- See Hilti Literature or third-party listings for complete application and installation details

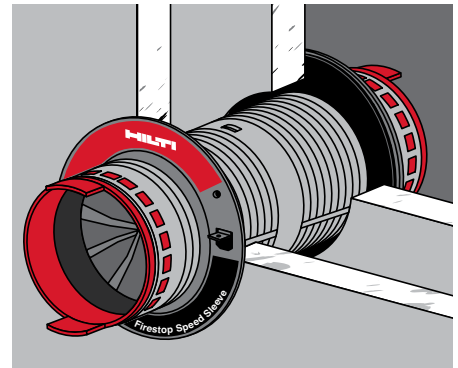

Technical Data

	2" (50 mm)	4" (102 mm)
OD (device only)	2.3" (60 mm)	4.3" (110 mm)
OD (flange)	4.7" (120 mm)	6.7" (170 mm)
ID	1.7" (48 mm)	3.6" (92 mm)
Total length	12.4" (315 mm)	12.4" (315 mm)
Weight (device and flanges)	1.5 lbs	2.6 lbs
Temperature resistance	-22° F to 212° F (-6° C to 100° C)	
Intumescent activation	Approx. 320° F (160° C)	
Expansion ratio (unrestricted)	1:40	
Metal	Steel with zinc coating	
Plastic	ABS	
Fabric	Glass-fiber	
Tested in accordance with	UL 1479 , ASTM E 814, CAN/ULC-S115	

