

BRASS PIPE AND TUB FITTINGS THROUGH CONCRETE FLOOR ASSEMBLY

F-RATING = 2-HR.

FT, FT AND FTH-RATINGS = 0-HR.

NOTE : TESTED WITH A 50 Pa PRESSURE DIFFERENTIAL

cUL FA1003a.110305

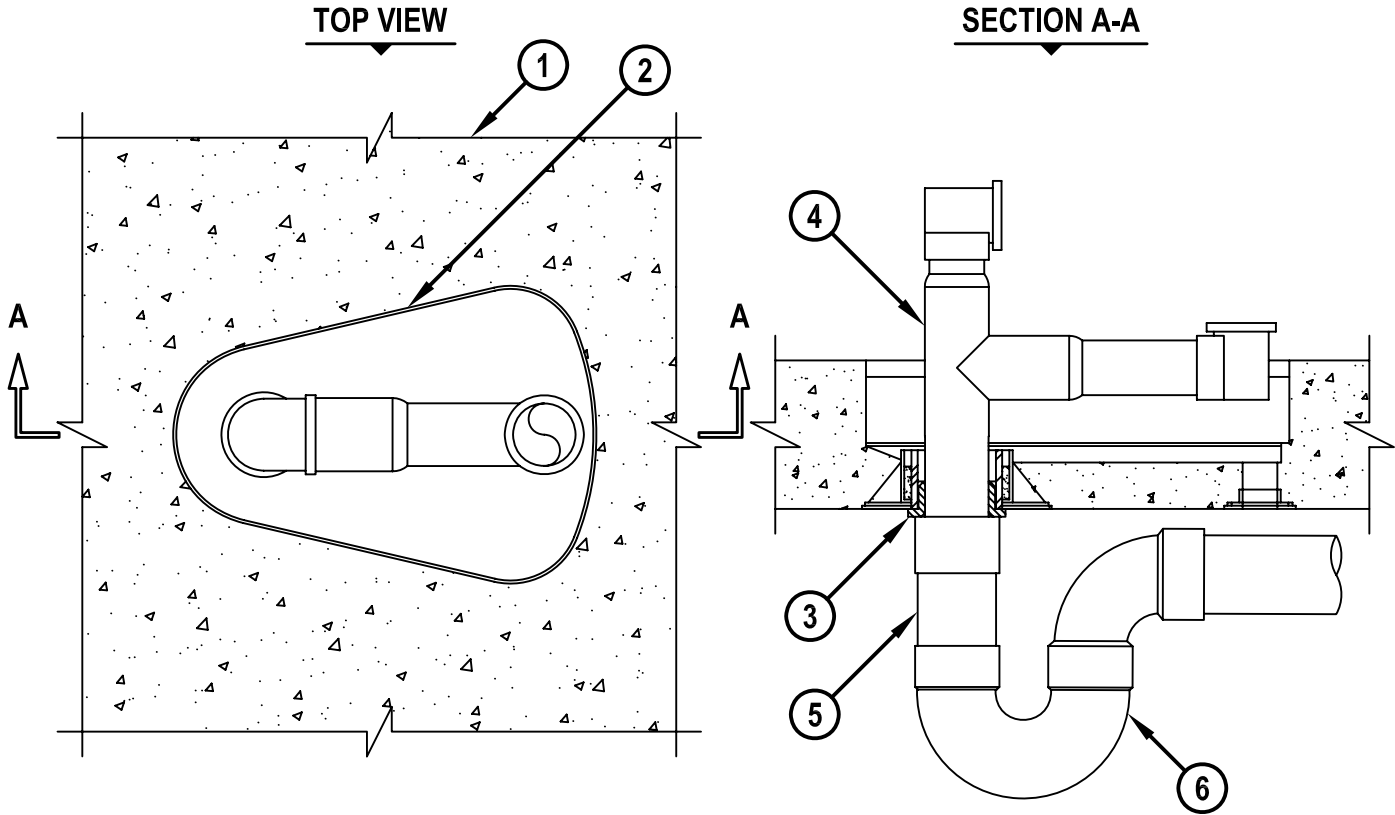

1. LIGHTWEIGHT OR NORMAL WEIGHT CONCRETE FLOOR ASSEMBLY (MINIMUM 4-1/2" THICK) (3-HR. FIRE-RATING).
2. HILTI CP 681 TUB BOX KIT, CONSISTING OF 8-1/2" x 12" x 2" DEEP ABS TUB BOX WITH ADJUSTABLE LEGS AND INTUMESCENT COUPLING, FASTENED TO FORM WORK AND PERMANENTLY EMBEDDED DURING CONCRETE PLACEMENT. MINIMUM 2" OF CONCRETE SHALL BE MAINTAINED BELOW TUB BOX.
3. ELASTOMERIC RUBBER BUSHING (PROVIDED BY HILTI, INC.) INSERTED INTO BOTTOM OF DEVICE. ELASTOMERIC BUSHING SIZED TO PROVIDE TIGHT FIT AROUND DRAIN PIPE (ITEM NO. 4).
4. MAXIMUM 1-1/2" NOMINAL DIAMETER BRASS WASTE/OVERFLOW FITTINGS.
5. MAXIMUM 2" NOMINAL DIAMETER PVC PLASTIC PIPE (SCHD 40) SECURED TO BRASS PIPE (ITEM NO. 4).
6. PVC OR CAST IRON P-TRAP PROPERLY SECURED TO DRAIN PIPING (ITEM NO. 5).

NOTE : DRAIN PIPING AND P-TRAPS (ITEMS NO. 4 AND NO. 5) SHOULD BE PROPERLY SUPPORTED AWAY FROM THE TUB BOX WITH SUITABLE HANGERS.



HILTI, Inc.
Tulsa, Oklahoma USA (918) 252-6000

Sheet	1 of 1
Scale	11/64" = 1"
Date	Nov. 03, 2005

Drawing No.
cUL
FA1003a