



The following excerpt are pages from the [North American Product Technical Guide Volume 3: Modular Support Systems Technical Guide, Edition 1](#) .

Please refer to the publication in its entirety for complete details on this product including load values, approvals/listings, general suitability, finishes, quality, etc.

To consult directly with a team member regarding our modular support system products, contact Hilti's team of technical support specialists between the hours of 7:00am – 6:00pm CST.

US: 877-749-6337 or HNATechnicalServices@hilti.com

CA: 1-800-363-4458, ext. 6 or CATechnicalServices@hilti.com

3.0 MODULAR SUPPORT SYSTEM

3.2 MT COMPONENTS

3.2.7 MT BRACKETS

Table 213 - Material Specifications and Ordering Information

Description	Material Specifications ^{1,2}	F _y ksi (MPa)	F _u ksi (MPa)	Type of Coating	Finish	Quantity Piece(s)	Item No.
MT-BR-30 300	EN-10025-2 S235 JR	34.08 (235)	53.66 (370)	Indoor	Electro-Galvanized	12	2271288
MT-BR-30 300 OC	EN-10025-2 S235 JR	34.08 (235)	53.66 (370)	Outdoor	Hot Dipped Galvanized	12	2271289
MT-BR-30 450	EN-10025-2 S235 JR	34.08 (235)	53.66 (370)	Indoor	Electro-Galvanized	16	2271440
MT-BR-30 450 OC	EN-10025-2 S235 JR	34.08 (235)	53.66 (370)	Outdoor	Hot Dipped Galvanized	16	2271441
MT-BR-40 300	GB/T 700 Q235 B	34.08 (235)	53.66 (370)	Indoor	Electro-Galvanized	10	2271442
MT-BR-40 300 OC	GB/T 700 Q235 B	34.08 (235)	53.66 (370)	Outdoor	Hot Dipped Galvanized	10	2271443
MT-BR-40 450	GB/T 700 Q235 B	34.08 (235)	53.66 (370)	Indoor	Electro-Galvanized	10	2271444
MT-BR-40 450 OC	GB/T 700 Q235 B	34.08 (235)	53.66 (370)	Outdoor	Hot Dipped Galvanized	10	2271445
MT-BR-40 600	GB/T 700 Q235 B	34.08 (235)	53.66 (370)	Indoor	Electro-Galvanized	10	2271451
MT-BR-40 600 OC	GB/T 700 Q235 B	34.08 (235)	53.66 (370)	Outdoor	Hot Dipped Galvanized	10	2271452
MT-BR-40 1000	GB/T 700 Q235 B	34.08 (235)	53.66 (370)	Indoor	Electro-Galvanized	10	2271446
MT-BR-40 1000 OC	GB/T 700 Q235 B	34.08 (235)	53.66 (370)	Outdoor	Hot Dipped Galvanized	10	2271447
MT-BR-40 O4 600 OC	GB/T 700 Q235 B	34.08 (235)	53.66 (370)	Outdoor	Hot Dipped Galvanized	4	2271455
MT-BR-40 O4 1000 OC	GB/T 700 Q235 B	34.08 (235)	53.66 (370)	Outdoor	Hot Dipped Galvanized	4	2271456
MT-BR-40D 600	GB/T 700 Q235 B	34.08 (235)	53.66 (370)	Indoor	Electro-Galvanized	6	2271448
MT-BR-40D 600 OC	GB/T 700 Q235 B	34.08 (235)	53.66 (370)	Outdoor	Hot Dipped Galvanized	6	2271449
MT-BR-40D 1000	GB/T 700 Q235 B	34.08 (235)	53.66 (370)	Indoor	Electro-Galvanized	6	2271450
MT-BR-40D 1000 OC	GB/T 700 Q235 B	34.08 (235)	53.66 (370)	Outdoor	Hot Dipped Galvanized	6	2271453
MT-BR-40D O4 600 OC	GB/T 700 Q235 B	34.08 (235)	53.66 (370)	Outdoor	Hot Dipped Galvanized	4	2271459
MT-BR-40D O4 1000 OC	GB/T 700 Q235 B	34.08 (235)	53.66 (370)	Outdoor	Hot Dipped Galvanized	4	2271461
MT-BR-40D O4 1500 OC	GB/T 700 Q235 B	34.08 (235)	53.66 (370)	Outdoor	Hot Dipped Galvanized	2	2271287

1. Mechanical properties of EN-10025-2 Grade S235 JR meet or exceed the mechanical properties of ASTM A1011 SS Grade 33.

2. Mechanical properties of GB/T 700 Grade Q235 B meet or exceed the mechanical properties of ASTM A1011 SS Grade 33.

3.0 MODULAR SUPPORT SYSTEM

3.2 MT COMPONENTS

3.2.7 MT BRACKETS

Table 214 - MT Bracket Dimensions

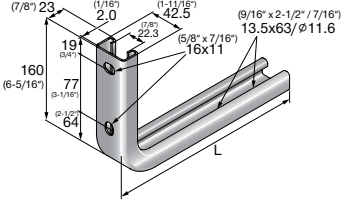
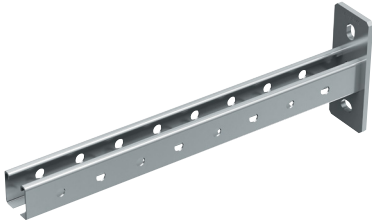
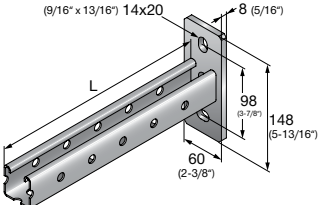
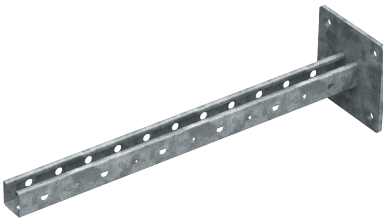
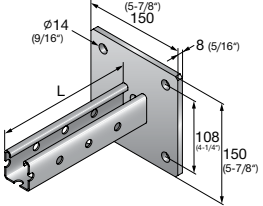
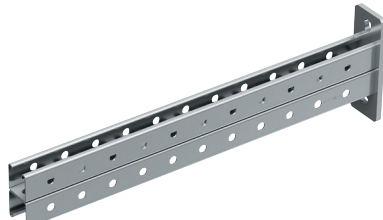
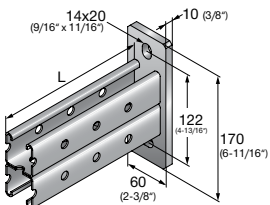
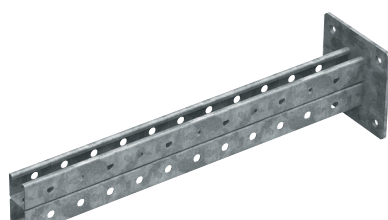
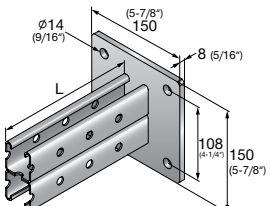
<p>MT-BR-30 300, MT-BR-30 300 OC MT-BR-30 450, MT-BR-30 450 OC Bent bracket – 13/16" (14 gauge) equivalent channel</p>		 <p>mm (in)</p>
<p>MT-BR-40 300, MT-BR-40 300 OC MT-BR-40 450, MT-BR-40 450 OC MT-BR-40 600, MT-BR-40 600 OC MT-BR-40 1000, MT-BR-40 1000 OC Cantilever arm with 1-5/8" (14 gauge) equivalent channel</p>		 <p>mm (in)</p>
<p>MT-BR-40 O4 600 OC MT-BR-40 O4 1000 OC 4-hole channel bracket – 1-5/8" (14 gauge) equivalent channel</p>		 <p>mm (in)</p>
<p>MT-BR-40D 600, MT-BR-40D 600 OC MT-BR-40D 1000, MT-BR-40D 1000 OC 2-hole channel bracket – back-to-back 1-5/8" (14 gauge) equivalent channel</p>		 <p>mm (in)</p>
<p>MT-BR-40D O4 600 OC MT-BR-40D O4 1000 OC MT-BR-40D OC 1500 OC 4-hole channel bracket – back-to-back 1-5/8" (14 gauge) equivalent channel</p>		 <p>mm (in)</p>

*See Instructions For Use (IFU), packaged with the product, for special Installation parameters and additional hardware required.

3.0 MODULAR SUPPORT SYSTEM

3.2 MT COMPONENTS

3.2.7 MT BRACKETS

Figure 81 - MT-BR-30

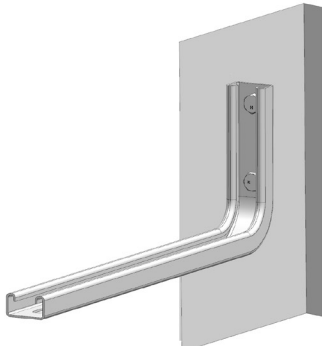

Figure 82 - MT-BR-40

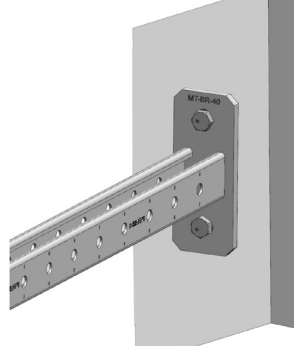
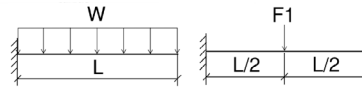
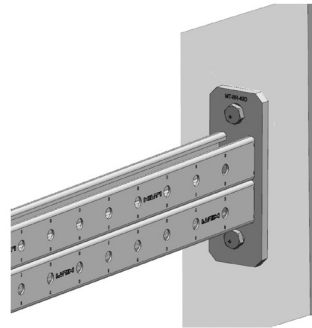

Figure 83 - MT-BR-40D

Table 216 - Limit State Design (LSD) Load Data^{1,5,6,7}

Bracket	Weight lbs (kg)	L in (mm)	W lb/in (N/cm)	F1 lb (kN)
MT-BR-30 300 (OC)²	1.43 (0.65)	11-13/16 (300)	30.46 (53.86)	360 (1.62)
MT-BR-30 450 (OC)²	1.93 (0.88)	17-11/16 (450)	13.67 (23.94)	240 (1.08)
MT-BR-40 300 (OC)²	2.49 (1.13)	11-13/16 (300)	99.86 (174.89)	1,180 (5.25)
MT-BR-40 450 (OC)²	3.15 (1.43)	17-11/16 (450)	44.31 (77.73)	785 (3.50)
MT-BR-40 600 (OC)²	3.84 (1.74)	23-5/8 (600)	24.97 (43.72)	590 (2.62)
MT-BR-40 1000 (OC)²	5.64 (2.56)	39-3/8 (1000)	8.89 (15.74)	350 (1.57)
MT-BR-40 O4 600 OC	5.69 (2.58)	23-5/8 (600)	27.52 (48.34)	650 (2.90)
MT-BR-40 O4 1000 OC	7.50 (3.40)	39-3/8 (1000)	9.91 (17.40)	390 (1.74)
MT-BR-40D 600 (OC)^{3,4}	3.84 (1.74)	23-5/8 (600)	75.57 (132.45)	1,785 (7.95)
MT-BR-40D 1000 (OC)^{3,4}	5.64 (2.56)	39-3/8 (1000)	27.18 (47.68)	1,070 (4.77)
MT-BR-40D O4 600 OC	8.40 (3.81)	23-5/8 (600)	75.57 (132.45)	1,785 (7.95)
MT-BR-40D O4 1000 OC	12.02 (5.45)	39-3/8 (1000)	27.18 (47.68)	1,070 (4.77)
MT-BR-40D O4 1500 OC	16.49 (7.48)	59-1/16 (1500)	12.10 (21.19)	715 (3.18)

1. Maximum resistance factor, Ω , for tabulated values is 0.65.
2. No reductions to tabulated loads need to be applied for bracket attachment to channel.
3. For bracket attachment to 14 gauge vertical channel, multiply tabulated load values by 0.52.
4. For bracket attachment to 12 gauge (e.g. MT-50) vertical channel, multiply tabulated load values by 0.57.
5. The loads apply only when channel profile opening is facing upward or downward.
6. The bracket's self-weight has been accounted for in the table load values.
7. Load values are for bracket only. Design professional is responsible for checking base material and fastener strength.