

TOP OF WALL JOINT : GYPSUM WALL ASSEMBLY

ASSEMBLY RATING = 1-HR. OR 2-HR.

CLASS II MOVEMENT CAPABILITIES - 40% COMPRESSION OR EXTENSION

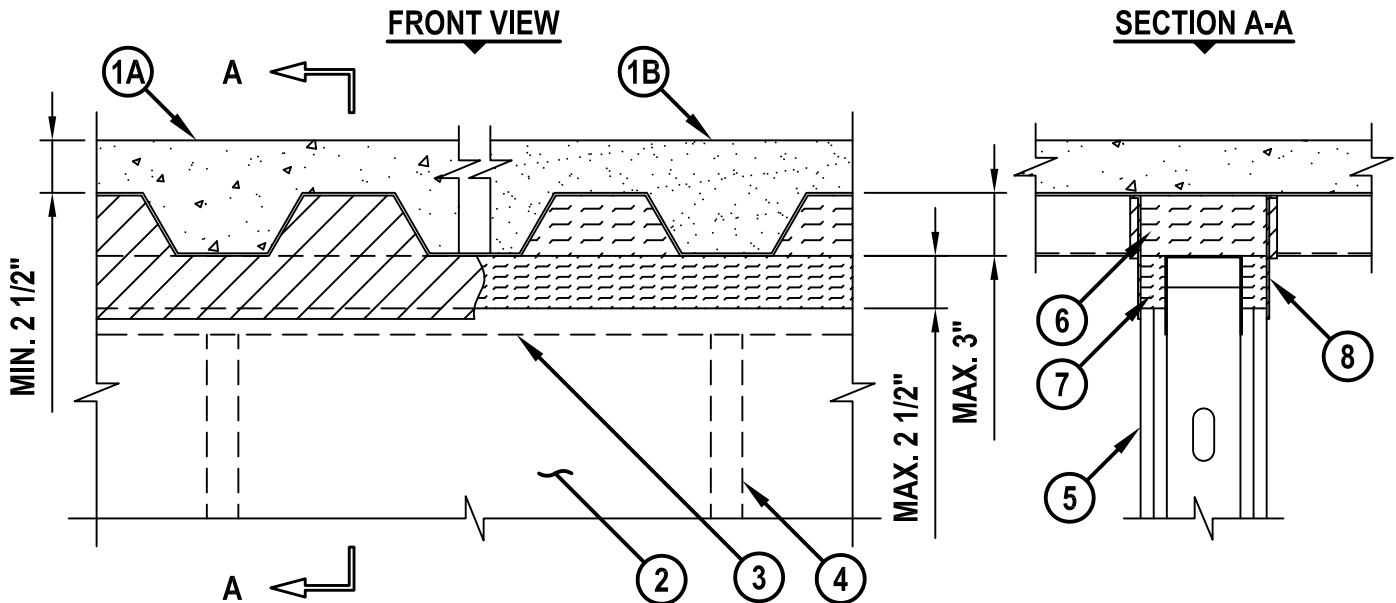

HWD1006c.052510

1. FLOOR OR ROOF ASSEMBLY (1-HR. OR 2-HR. FIRE-RATING) :
 - A. LIGHTWEIGHT OR NORMAL WEIGHT CONCRETE FLOOR (MIN. 2-1/2" THICK) OVER METAL DECKING (UL/cUL CLASSIFIED D900 SERIES).
 - B. INSULATING CONCRETE (MIN. 2-1/4" THICK) OVER METAL DECKING (UL/cUL CLASSIFIED P900 SERIES).
2. GYPSUM WALL ASSEMBLY (UL/cUL CLASSIFIED U400 OR V400 SERIES) (1-HR. OR 2-HR. FIRE-RATING).
3. CEILING RUNNER (MIN. 25 GA., FLANGE HEIGHT OF CEILING RUNNER SHALL BE MINIMUM 1/4" GREATER THAN MAXIMUM EXTENDED JOINT WIDTH) FASTENED TO UNDERSIDE OF DECK WITH STEEL MASONRY ANCHORS, STEEL FASTENERS, OR WELDS (SPACED MAX. 24" O.C.).
4. STEEL STUDS (MINIMUM 3-1/2" WIDE), CUT 1-1/4" TO 1-1/2" LESS IN LENGTH THAN ASSEMBLY HEIGHT, NESTING IN CEILING RUNNER WITHOUT ATTACHMENT.
5. 5/8" OR 1-1/4" THICKNESS GYPSUM WALLBOARD AS SPECIFIED IN THE INDIVIDUAL UL DESIGN. TOP ROW OF SCREWS SHALL BE INSTALLED INTO STUDS 5" BELOW THE BOTTOM PLANE OF FLOOR/ROOF.
6. HILTI CP 777 SPEED PLUGS FRICTION FITTED TO COMPLETELY FILL FLUTE, FLUSH WITH BOTH SIDES OF WALL (SEE NOTE BELOW).
7. HILTI CP 767 SPEED STRIPS COMPRESSED 50% AND INSERTED INTO JOINT, FLUSH WITH BOTH SIDES OF GYPSUM WALL (SEE NOTE BELOW).
8. MINIMUM 1/8" (WET) THICKNESS HILTI CFS-SP WB FIRESTOP JOINT SPRAY OR HILTI CP 672 SPEED SPRAY TO COMPLETELY COVER MINERAL WOOL AND TO OVERLAP A MINIMUM 1/2" ONTO GYPSUM WALL AND METAL DECKING ON BOTH SIDES OF GYPSUM WALL ASSEMBLY.

NOTE : AS AN ALTERNATE TO HILTI CP 767 SPEED STRIPS, AND/OR CP 777 SPEED PLUGS, MINERAL WOOL (MIN. 4 PCF DENSITY) COMPRESSED 50% MAY BE USED.



HILTI, Inc.
Tulsa, Oklahoma USA (800) 879-8000

Sheet	1 of 1
Scale	7/64" = 1"
Date	May 25, 2010

Drawing No.
**HWD
1066c**