

cUL SYSTEM NO. W-L-2845

# PLASTIC PIPE THROUGH GYPSUM WALL ASSEMBLY

F-RATING = 1-HR. OR 2-HR.

FT-RATING = 0-HR. OR 1-HR.

FH AND FTH-RATINGS = 0-HR.

NOTE : TESTED WITH A 50 Pa PRESSURE DIFFERENTIAL



cUL WL2845a.081623

AUXILIARY VIEW

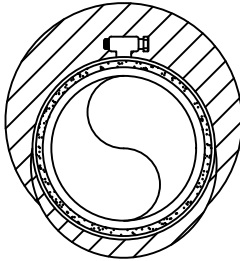

CROSS-SECTIONAL VIEW

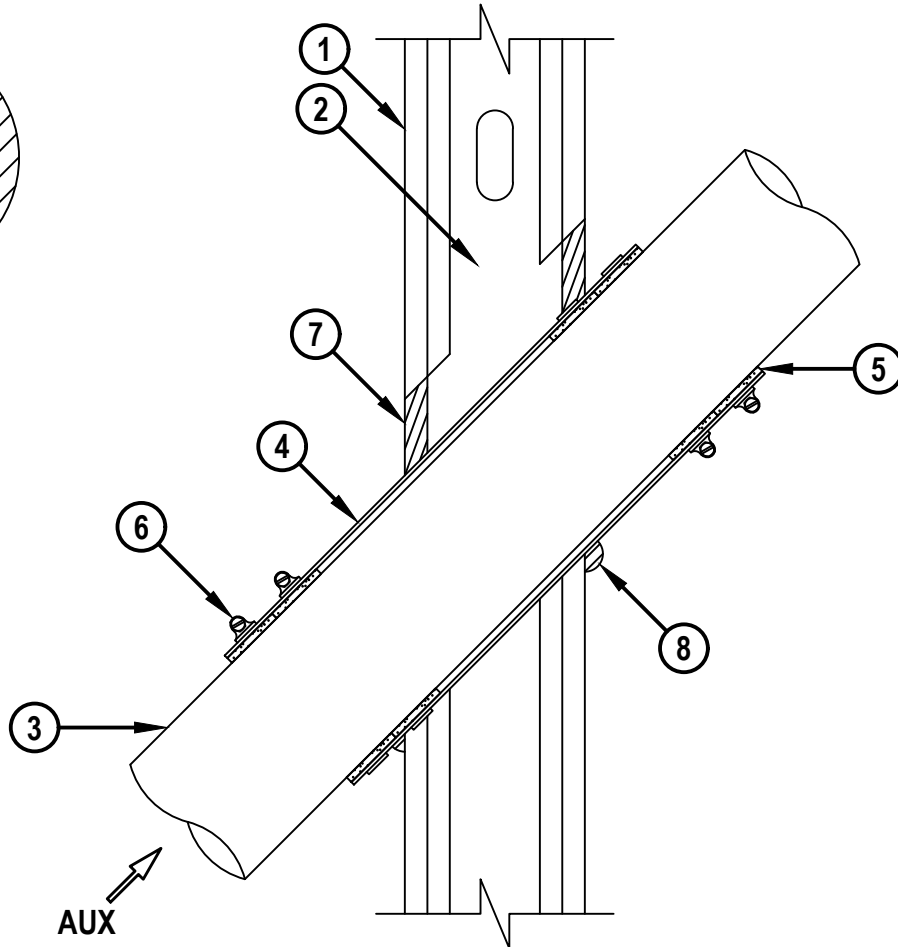

HILTI, Inc.  
Plano, Texas USA (800) 879-8000

Sheet	1 of 2
Scale	3/16" = 1"
Date	Aug. 16, 2023

Drawing No.  
**cUL**  
**WL2845a**

*Saving Lives through Innovation and Education*

cUL SYSTEM NO. W-L-2845



# PLASTIC PIPE THROUGH GYPSUM WALL ASSEMBLY

F-RATING = 1-HR. OR 2-HR.

FT-RATING = 0-HR. OR 1-HR.

FH AND FTH-RATINGS = 0-HR.

NOTE : TESTED WITH A 50 Pa PRESSURE DIFFERENTIAL

cUL WL2845a.081623

1. GYPSUM WALL ASSEMBLY (UL/cUL CLASSIFIED U400, V400, OR W400 SERIES) (1-HR. OR 2-HR. FIRE-RATING) (2-HR. SHOWN).
2. STEEL STUDS TO BE MINIMUM 2-1/2" WIDE (SPACED MAXIMUM 24" O/C).
3. PENETRATING ITEM TO BE ONE OF THE FOLLOWING AND INSTALLED AT AN ANGLE NOT GREATER THAN 45° FROM PERPENDICULAR :
  - A. MAXIMUM 4" NOMINAL DIAMETER XFR-PVC PLASTIC PIPE (SCHEDULE 40) (SOLID CORE) (CLOSED OR VENTED PIPING SYSTEM).
4. MAXIMUM 5-1/4" NOMINAL DIAMETER SHEET METAL SLEEVE (MIN. 28 GA.) HAVING A MINIMUM 1" LAP ALONG LONGITUDINAL SEAM. LENGTH OF SLEEVE TO EXTEND 2" BEYOND EACH SURFACE OF WALL. SLEEVE TO BE COMPRESSED AROUND THE PIPE (ITEM 3) AND WRAP STRIP (ITEM 5) USING HOSE CLAMPS (ITEM 6).
5. HILTI CP 648E WRAP STRIP (NOMINAL 3/16" THICK x 1-3/4" WIDE) CONTINUOUSLY WRAPPED AROUND THE OUTER CIRCUMFERENCE OF THE PIPE, IN TWO ADJACENT SINGLE-LAYER STACKS, AND HELD IN PLACE WITH TAPE. WRAP STRIP IS INSTALLED FLUSH WITH ENDS OF SHEET METAL SLEEVE.
6. NOMINAL 1/2" WIDE STAINLESS STEEL HOSE CLAMP(S) FASTENED AROUND SHEET METAL SLEEVE AT THE CENTER OF EACH WRAP STRIP.
7. MINIMUM 5/8" DEPTH HILTI FS-ONE MAX INTUMESCENT FIRESTOP SEALANT.
8. MINIMUM 1/2" BEAD HILTI FS-ONE MAX INTUMESCENT FIRESTOP SEALANT APPLIED AT POINT OF CONTACT.

NOTES : 1. MAXIMUM DIMENSIONS OF OVAL OPENING ARE 6" WIDE BY 8-3/4" TALL.  
 2. ANNULAR SPACE BETWEEN SLEEVE AND PERIPHERY OF OPENING = MINIMUM 0", MAXIMUM 1-1/2".



HILTI, Inc.  
 Plano, Texas USA (800) 879-8000

Sheet	2 of 2
Scale	-
Date	Aug. 16, 2023

Drawing No.  
**cUL**  
**WL2845a**