



Classified by
Underwriters Laboratories, Inc.
to UL 1479 and CAN/ULC-S115

System No. W-L-7321

WL 7321

ANSI/UL1479 (ASTM E814)	CAN/ULC S115
F Rating — 1 and 2 Hr (See Item 1)	F Rating — 1 and 2 Hr (See Item 1)
T Rating — 1/2 Hr	FT Rating — 1/2 Hr
L Rating At Ambient — 1 CFM/ft ²	FH Rating — 1 and 2 Hr (See Item 1)
L Rating At 400 F — Less Than 1 CFM/ft ²	FTH Rating — 1/2 Hr
	L Rating At Ambient — Less than 5.1 L/s/m ²
	L Rating At 204 C — Less Than 5.1 L/s/m ²

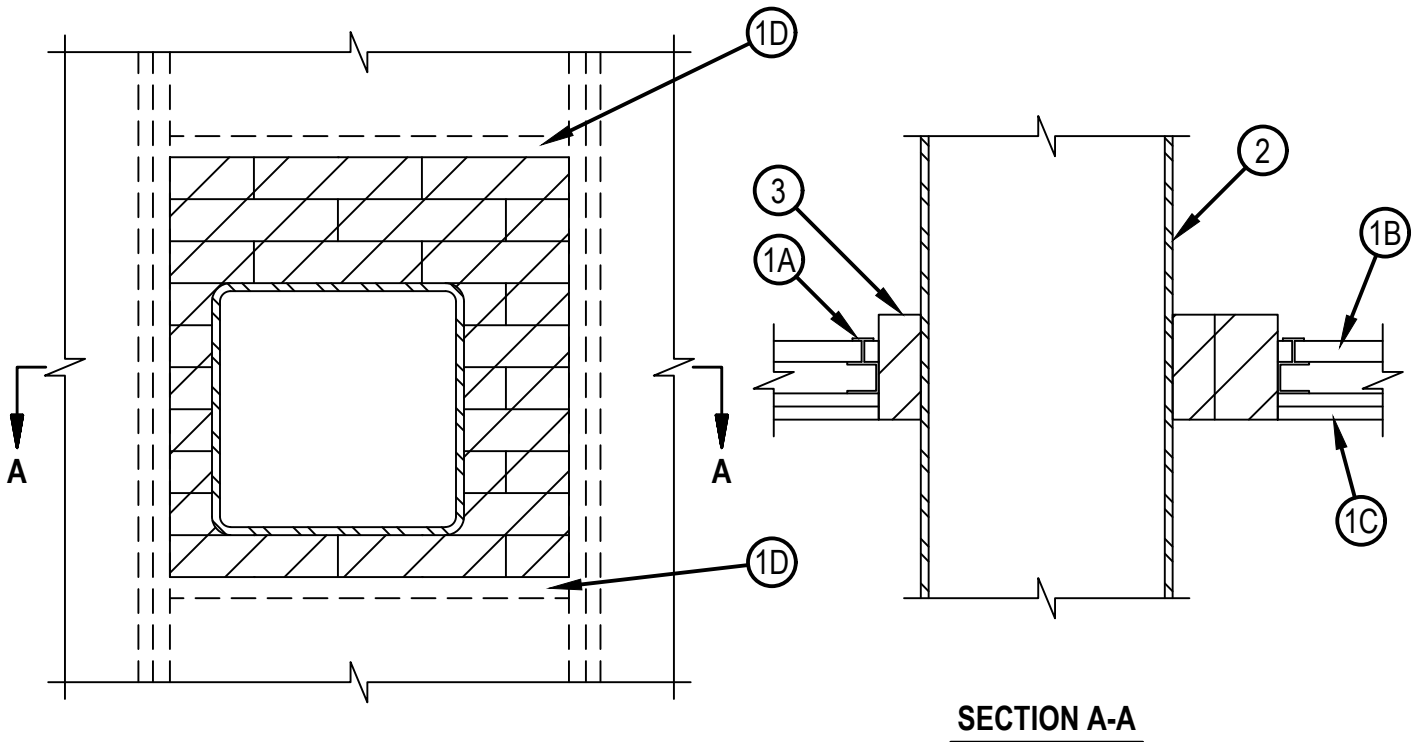

Reproduced by HILTI, Inc. Courtesy of
Underwriters Laboratories, Inc.
June 29, 2021

1. Wall Assembly —The 1 or 2 hr fire rated gypsum board/stud wall assembly shall be constructed of the materials and in the manner specified in the individual U400, V400, or W400 Series Wall and Partition Designs in the UL Fire Resistance Directory and shall include the following construction features:
 - A. Steel Studs —"C-H" or "C-T" shaped studs, min 2-1/2 in. (64 mm) wide by 1-1/2 in. (38 mm) deep, fabricated from min No. 20 gauge galv steel, spaced max 24 in. (610 mm) OC. Steel studs to frame the vertical sides of the opening when opening width exceeds 20 in. (508 mm).
 - B. Gypsum Board* —1 in. (25 mm) thick, 24 in. (610 mm) wide gypsum liner panels installed vertically. When the opening spans the entire distance between studs, an additional 5/8 in. (13 mm) wide strip of the 1 in. (25 mm) thick liner panel is to be installed within the open portion of the C-H /C-T studs framing the opening.
 - C. Gypsum Board* —1/2 in. or 5/8 in. (13 or 16 mm) thick, 48 in. (1.2 m) wide gypsum boards. The gypsum board type, thickness, number of layers, fastener type and sheet orientation shall be as specified in the individual Wall and Partition Design. The maximum opening is 22-5/8 in. (575 mm) wide by 25 in. (635 mm) high.
 - D. J-Runner —Min 2-1/2 in. (64 mm) wide, 20 gauge (or heavier) galvanized steel runner used as the horizontal framing of the opening. Runner to be secured to C-H/C-T studs on each side of opening with min 1-1/2 in. (38 mm) long Type S steel screws. Steel runner used to frame the vertical sides of the opening and shall be attached to the horizontal runners with min 1-1/2 in. (38 mm) long Type S steel screws when opening width is 20 in. (508 mm) or less.

The F and FH Ratings are equal to the hourly rating of the wall.

2. Through Penetrant —One nom 18 by 18 in. (457 by 457 mm) (or smaller) by min 0.38 in. (9.65 mm) thick structural steel tube service support to be installed within the firestop system. An annular space of min 1-1/4 in. (32 mm) to max 5-1/4 in. (133 mm) is required between the steel tube and the periphery of the opening. Steel tube may be filled with concrete, grout or mortar. Steel tube to be rigidly supported on both sides of wall assembly.
3. Fill Void or Cavity Materials* - Fire Blocks — Fire blocks installed with 5 in. (127 mm) dimension projecting through opening, flush with the finished side of the wall. Blocks to be firmly packed and completely fill the entire area of opening.
HILTI CONSTRUCTION CHEMICALS, DIV OF HILTI INC — CFS-BL Firestop Block
4. Fill, Void or Cavity Material* — Sealant (Optional, Not Shown)— If surface voids larger than 1/4 in. (6 mm) within firestop block exist, fill material applied to the maximum extent possible to fill any voids within the annular space around the penetrant, on either surface of wall assembly.
HILTI CONSTRUCTION CHEMICALS, DIV OF HILTI INC — FS-ONE MAX Intumescent Sealant

* Indicates such products shall bear the UL or cUL Certification Mark for jurisdictions employing the UL or cUL Certification (such as Canada), respectively.

