



Classified by
Underwriters Laboratories, Inc.
to UL 1479 and CAN/ULC-S115

System No. F-A-5084

FA 5084

ANSI/UL1479 (ASTM E814)	CAN/ULC S115
F Rating — 3 Hr	F Rating — 3 Hr
T Ratings — 0, 1/2, 3/4, 1, 3 Hr (See Item 3)	FT Ratings — 0, 3/4, 1, 3 Hr (See Item 3)
L Rating at Ambient – See Item 3	FH Rating — 3 Hr
L Rating at 400°F – See Item 3	FTH Ratings — 0, 3/4, 1, 3 Hr (See Item 3)
	L Rating at Ambient – See Item 3
	L Rating at 204°C – See Item 3

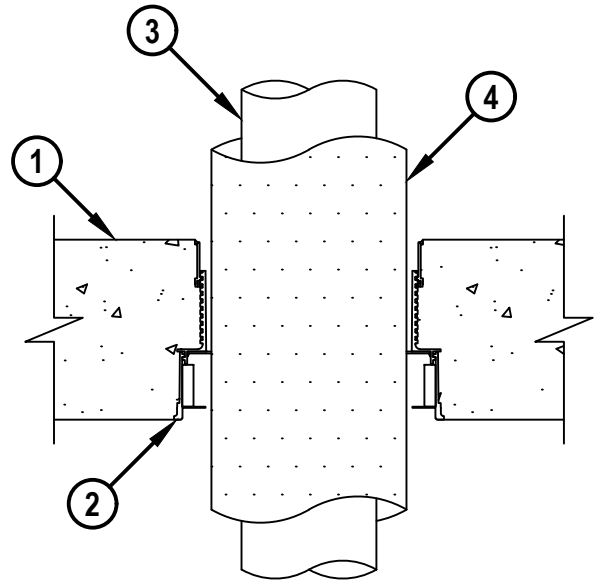
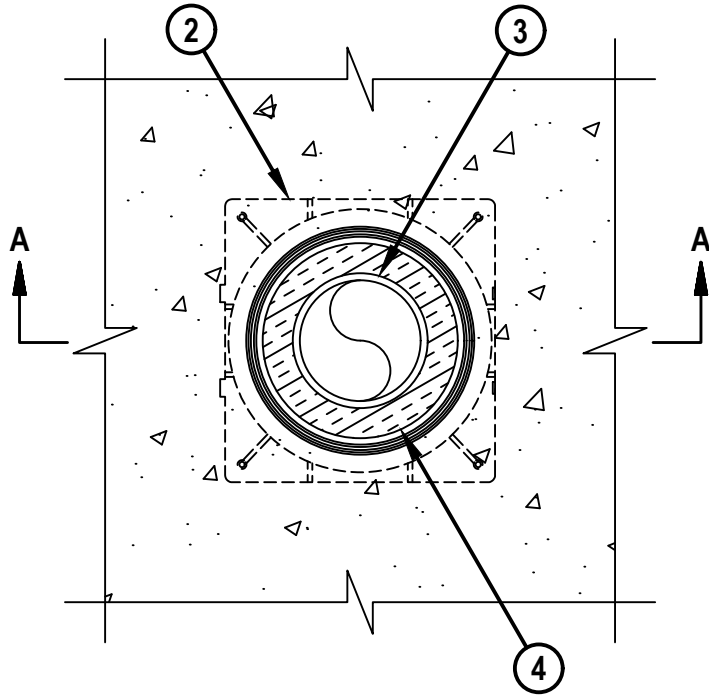

SECTION A-A

1. Floor Assembly — Min 4-1/2 in. (114 mm) thick reinforced lightweight or normal weight (100-150 pcf or 1600-2400 kg/m³) concrete.
2. Firestop Device* — Cast in place firestop device with optional accessories including sleeve extension permanently embedded during concrete placement or grouted in concrete floor assembly in accordance with accompanying installation instructions with a max 2 in. (51 mm) projection above the top surface of the concrete.
HILTI CONSTRUCTION CHEMICALS, DIV OF HILTI INC — CFS-CID U 2", CFS-CID U 2" CA, CFS-CID U 3", CFS-CID U 4", CFS-CID U 6"
3. Through Penetrants — One metallic pipe or tubing to be installed within the firestop device. Pipe or tubing to be rigidly supported on both sides of floor assembly. The following types of pipe or tubing may be used:
 - A. Steel Pipe — Nom 4 in. (102 mm) diam (or smaller) Schedule 10 (or heavier) steel pipe.
 - B. Iron Pipe — Nom 4 in. (102 mm) diam (or smaller) cast or ductile iron pipe
 - C. Copper Tubing — Nom 4 in. (102 mm) diam (or smaller) Type L (or heavier) copper tubing.
 - D. Copper Pipe — Nom 4 in. (102 mm) diam (or smaller) Regular (or heavier) copper pipe.

The firestop device, metallic penetrant and pipe covering shall be sized as follows :



Hilti Firestop Systems

Reproduced by HILTI, Inc. Courtesy of
Underwriters Laboratories, Inc.
September 25, 2023

System No. F-A-5084

FA 5084

Nom Pipe Diameter, in. (mm)	Nom Thick of Pipe Covering, in. (mm)	Firestop Device	T, FT and FTH Ratings, Hr	L Rating at Ambient CFM/sq ft (L/s/m ²)	L Rating at 400F (204°C) CFM/sq ft (L/s/m ²)
1/2 (13)	1 (25)	CFS-CID U 2" CFS-CID U 2" CA	2-1/2	3 (15.2)	1.5 (7.6)
1/2 (13)	1 (25)	CFS-CID U 2" CFS-CID U 2" CA	2-3/4	3 (15.2)	1.5 (7.6)
1 (25)	1 (25)	CFS-CID U 3"	1-3/4	3 (15.2)	1.5 (7.6)
1 (25) (See Item 5)	1-1/2 (38)	CFS-CID U 4"	3	N/A	N/A
2 (51)	1 (25)	CFS-CID U 4"	1-3/4	3 (15.2)	1.5 (7.6)
2 (51)	1 (25)	CFS-CID U 4"	2-3/4	3 (15.2)	1.5 (7.6)
2 (51)	2 (51)	CFS-CID U 6"	2-3/4	Less Than 1(Less Than 5.1)	Less Than 1(Less Than 5.1)
4 (102)	1 (25)	CFS-CID U 6"	2	3 (15.2)	1.5 (7.6)

4. Pipe Covering* — Nom 1, 1-1/2 and 2 in. (25, 38 and 51 mm) thick hollow cylindrical heavy density (min 3.5 pcf or 56 kg/m³) glass fiber units, jacketed on the outside with an all service jacket. Longitudinal joints sealed with metal fasteners or factory-applied SSL tape. Transverse joints secured with metal fasteners or with butt tape supplied with the product.

See Pipe and Equipment Covering-Materials (BRGU) category in the Building Materials Directory for names of manufacturers. Any pipe covering material meeting the above specifications and bearing the UL Classification Marking with a Flame Spread Index of 25 or less and a Smoke Developed Index of 50 or less may be used.

5. Packing Material — When using a 1 in. (25 mm) diam pipe with 1-1/2 in. (38 mm) thick glass fiber pipe insulation in a 4 in. (102 mm) device, a min 2 in. (51 mm) thickness of min 4 pcf (64 kg/m³) mineral wool batt insulation shall be firmly packed into the top of device, flush with the top of the device. When pipe sizes are less than those shown in the table in Item 3, min 4 in. (102 mm) thickness of min 4 pcf (64 kg/m³) mineral wool insulation shall be firmly packed to the fullest extent possible within the device flush with top surface of device.

6. Fill, Void or Cavity Material*- Sealant — (optional) Min ¼ in (6mm) thickness of sealant applied within the annulus, flush with the top surface of the floor.

HILTI CONSTRUCTION CHEMICALS, DIV OF HILTI INC – CFS-S SIL GG or CFS-S SIL SL Sealant

* Indicates such products shall bear the UL or cUL Certification Mark for jurisdictions employing the UL or cUL Certification (such as Canada), respectively.



Hilti Firestop Systems

Reproduced by HILTI, Inc. Courtesy of
Underwriters Laboratories, Inc.
September 25, 2023