



Classified by
Underwriters Laboratories, Inc.
to CAN/ULC-S115

System No. F-A-2012



FA 2012

- F Ratings — 1, 2 and 3 Hr (See Item 3)**
FT Ratings — 0, 1/4, 3/4 and 2 Hr (See Items 2, 3 and 4)
FH Ratings — 0 and 3 Hr (See Item 3)
FTH Ratings — 0 and 2 Hr (See Items 2 and 3)
L Rating At Ambient — Less Than 1 CFM/sq ft (See Item 2)
L Rating At 400 F — Less Than 1 CFM/sq ft (See Item 2)

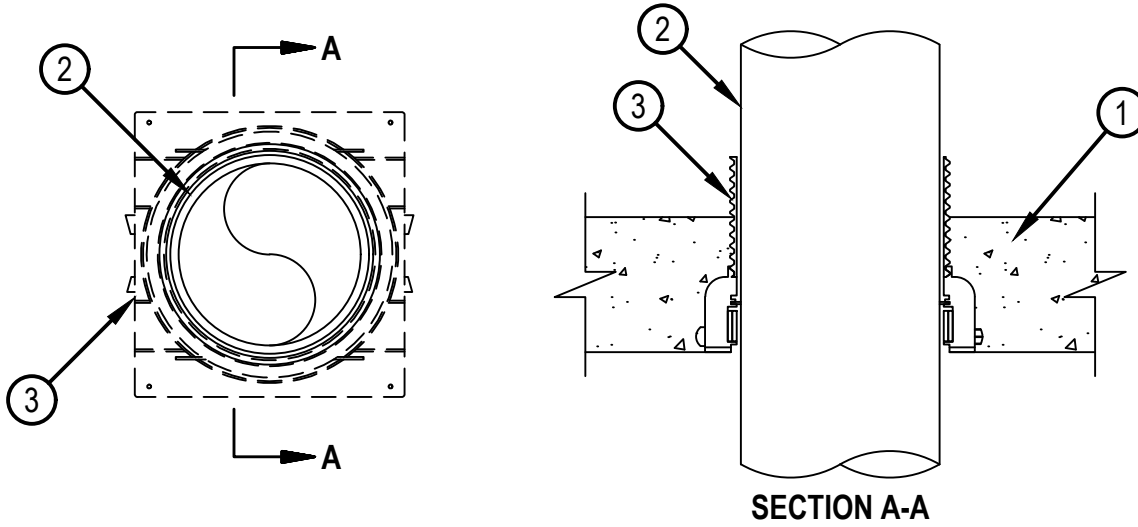

System tested with a pressure differential of 50 Pa between the exposed and the unexposed surfaces with the higher pressure on the exposed side.
 1. Floor Assembly — Min 64, 114 or 152 mm (2-1/2, 4-1/2 or 6 in.) thick normal weight concrete (2400 kg/m³ or 150 pcf). See Items 2D and 2E and Table in Item 3.

1A. Floor Assembly — (Optional — Not Shown) - The fire-rated unprotected concrete and steel deck floor assembly shall be constructed of the materials and in the manner specified in the individual D900 Series designs in the UL Fire Resistance Directory and as summarized below.

- A. Concrete — Min 64, 114 or 152 mm (2-1/2, 4-1/2 or 6 in.) thick normal weight concrete (2400 kg/m³ or 150 pcf). See table in Item 3.
- B. Steel Floor and Form Units — Composite or non-composite, max 76 mm (3 in.) deep galv steel fluted units as specified in the individual floor-ceiling design.

2. Through Penetrant — One nonmetallic pipe to be centered within the firestop system. Pipe to be rigidly supported on both sides of floor assembly. The following types and sizes of pipe may be used:

- A. Polyvinyl Chloride (PVC) Pipe — Schedule 40 solid or cellular core PVC for use in closed (process or supply) or vented (drain, waste or vent) piping systems. See Table under Item 3 for pipe size.
- B. Chlorinated Polyvinyl Chloride (CPVC) Pipe — SDR11, SDR 13.5 or SDR17 CPVC for use in closed (process or supply) or vented (drain, waste or vent) piping systems. See Table under Item 3 for pipe size.
- C. Chlorinated Polyvinyl Chloride (CPVC) Pipe — Nom 152 mm (6 in.) diam (or smaller) SDR 11 CPVC for use in closed (process or supply) piping systems.
IPEX INC — AquaRise
- D. Acrylonitrile Butadiene Styrene (ABS) Pipe — Nom 102 mm (4 in.) diam (or smaller) Schedule 40 cellular or solid core pipe for use in closed (process or supply) or vented (drain, waste or vent) piping systems. Minimum floor thickness is 114 mm (4-1/2 in.) when ABS pipe is used. FT and FTH Ratings are 0 hr for ABS pipe.
- E. Fire Retardant Polypropylene (FRPP) Pipe — Nom 156 mm (6 in.) diam (or smaller) Schedule 40 FRPP pipe for use in closed (process or supply) or vented (drain, waste or vent) piping systems. Minimum floor thickness is 114 mm (4-1/2 in.) when FRPP pipe is used. FT and FTH Ratings are 0 hr for FRPP pipe.
- F. Rigid Nonmetallic Conduit+ — Nom 102mm (4 in.) diam (or smaller) Schedule 40 PVC conduit installed in accordance with the National Electrical Code (NFPA No. 70).
- G. Polyvinyl Chloride (PVC) Pipe — Nom 152 mm (6 in.) diam (or smaller) Schedule 40 solid or cellular core PVC for use in closed (process or supply) or vented (drain, waste or vent) piping systems.
IPEX INC — System 15 piping



Hilti Firestop Systems

Reproduced by HILTI, Inc. Courtesy of
Underwriters Laboratories, Inc.
July 31, 2024

System No. F-A-2012



FA 2012

3. Firestop Device* — Cast in place firestop device permanently embedded during concrete placement or grouted in concrete assembly in accordance with accompanying installation instructions with a max 51 mm (2 in.) projection above the top surface of the concrete.

HILTI CONSTRUCTION CHEMICALS, DIV OF HILTI INC — CP 680-75/2.5"N, CP 680-110/4"N, CP 680-160/6"N, CP 680-P 2", CP 680-P 3", CP 680-P 4", CP 680-P 6", CP 680-PX 2", CP 680-PX 3"

The ratings of the firestop systems are dependent on the size of the device, type and size of the penetrant, and the thickness of the concrete assembly as specified in the table below.

Min Concrete Thickness, mm (in.)	Nom Pipe Diam, mm (in.)	Penetrant Type (See Item 2)	Firestop Device	Rating, hr			
				F	FT	FH	FTH
64 (2-1/2)	51 (2)	All*	CP680-75/2.5"N CP 680-P 2" CP 680-PX 2"	2	3/4	0	0
64 (2-1/2)	76 (3)	All	CP 680-P 3" CP 680-PX 3"	2	0	0	0
64 (2-1/2)	102 (4)	All	CP680-110/4"N CP 680-P 4"	2	0	0	0
64 (2-1/2)	152 (6)	All	CP680-160/6"N CP 680-P 6"	2	0	0	0
114 (4-1/2)	38 (1.5)	All*	CP680 - 75/2.5"N CP 680-P 2" CP 680-PX 2"	2	2	0	0
114 (4-1/2)	76 (3)	All*	CP680-110/4"N CP 680-P 4"	3	2	3	2
114 (4-1/2)	76 (3)	All	CP 680-P 3" CP 680-P 3"	3	0	0	0
114 (4-1/2)	102 (4)	All	CP680-160/6"N CP 680-P 6"	1	0	0	0
114 (4-1/2)	51 (2)	All*	CP680-75/2.5"N CP 680-P 2" CP 680-PX 2"	2	2	0	0
114 (4-1/2)	102 (4)	All*	CP680-110/4"N CP 680-P 4"	3	2	3	2
114 (4-1/2)	152 (6)	All	CP680-160/6"N CP 680-P 6"	2	0	0	0
152 (6)	76 (3)	A, B, C, G	CP 680-P 3" CP 680-PX 3"	2	2	2	2

* When ABS or FRPP pipe is used, FT and FTH Ratings are 0 hr.



Hilti Firestop Systems

Reproduced by HILTI, Inc. Courtesy of
Underwriters Laboratories, Inc.
July 31, 2024

System No. F-A-2012



FA 2012

++ L Rating applies only to CP 680-P(X) devices and only when the nom diam of pipe equals size of device (2 in. diam pipe in 2" device etc.) Also applies only to PVC and CPVC pipes. L Rating does not apply when pipe covering and packing material are used.

4. Pipe Covering* — (Optional, Not Shown) - Min 13 mm (1/2 in.) thick hollow cylindrical glass fiber units with an all service jacket installed around 76 mm (3 in.) diam (or smaller) ABS or PVC pipe at the top of the floor and extending min 305 mm (12 in.) above floor surface or device. Longitudinal joints sealed with metal fasteners or factory-applied self-sealing lap tape. Transverse joints secured with metal fasteners or with butt tape supplied with the product. Prior to installation of pipe covering, packing material specified in Item 5 shall be installed as required. When pipe covering is used, FT Rating is 2 Hr.

See Pipe and Equipment Covering Materials (BRGU) category in the Building Materials Directory for names of manufacturers. Any pipe covering meeting the above specifications and bearing the UL Classification Marking with a Flame Spread Index of 25 or less and a Smoke Developed Index of 50 or less may be used.

5. Packing Material — (Not Shown) - Required as noted in Item 4 above for 2 hr FT Rating. When nom pipe size is less than device size (ie, nom 76 mm (3 in.) diam pipe in 102 mm (4 in.) device), min 32 mm (1-1/4 in.) thickness of min 64 kg/m³ (4 pcf) mineral wool batt insulation tightly packed to fill annular space between pipe and device, flush with top of device.

* Indicates such products shall bear the UL or cUL Certification Mark for jurisdictions employing the UL or cUL Certification (such as Canada), respectively.

+Bearing the UL Listing Mark



Hilti Firestop Systems

Reproduced by HILTI, Inc. Courtesy of
Underwriters Laboratories, Inc.
July 31, 2024

Page: 3 of 3