



Classified by
Underwriters Laboratories, Inc.
to CAN/ULC-S115

System No. F-A-5005

F Rating - 2 Hr

FT Ratings - 1/2 and 3/4 Hr (See Item 3)

FH Rating - 0 Hr

FTH Rating - 0 Hr



FA 5005

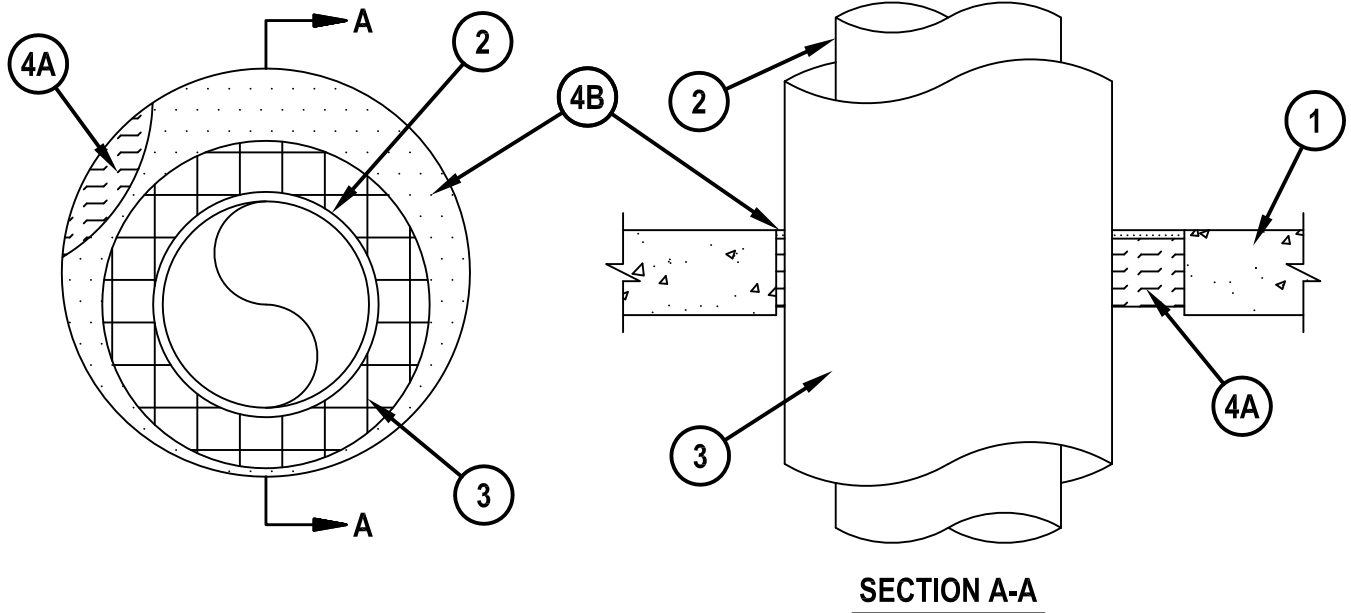

1. Floor Assembly — Min 64 mm (2-1/2 in) thick reinforced lightweight or normal weight 1600-2400 kg/m³ concrete. Max diam of opening is 203 mm (8 in).
2. Metallic Pipes — One metallic pipe or tubing to be installed eccentrically or concentrically within the firestop system. Pipe or tubing to be rigidly supported on both sides of the floor assembly.
 - A. Steel Pipe — Nom 102 mm (4 in.) diam (or smaller) Schedule 10 (or heavier) steel pipe.
 - B. Copper Tube — Nom 102 mm (4 in.) diam (or smaller) Type L (or heavier) copper tube.
 - C. Copper Pipe — Nom 102 mm (4 in.) diam (or smaller) Regular (or heavier) copper pipe.
 - D. Iron Pipe — Nom 102 mm (4 in.) diam (or smaller) cast iron or ductile iron pipe.
3. Pipe Covering* — Nom 38 or 25 mm (1-1/2 or 1 in.) thick hollow cylindrical heavy density min 56 kg/m³ (3.5 pcf) glass fiber units jacketed on the outside with an all service jacket. Longitudinal joints sealed with metal fasteners or factory-applied self-sealing lap tape. Transverse joints secured with metal fasteners or with butt tape supplied with the product. The annular space within the firestop system shall be min 6 mm (1/4 in.) to a max 130 mm (5-1/8 in.) is required within the firestop system.
See Pipe and Equipment Covering Materials (BRGU) category in the Building Materials Directory for names of manufacturers. Any pipe covering material meeting the above specifications and bearing the UL Classification Marking with a Flame Spread value of 25 or less and a Smoke Developed value of 50 or less may be used.
- B. Pipe Covering Materials* — Nom 38 or 25 mm (1-1/2 or 1 in.) thick unfaced mineral fiber pipe insulation having a nom density of 56 kg/m³ (3.5 pcf) or heavier and sized to fit the outside diam of pipe or tube. Pipe insulation secured with min 18 SWG steel wire spaced 305 mm (12 in.) OC. The annular space within the firestop system shall be min 6 mm (1/4 mm) to max 130 mm (5-1/8 in.).
IIG MINWOOL L L C — High Temperature Pipe Insulation 1200, High Temperature Pipe Insulation BWT and High Temperature Pipe Insulation Thermaloc

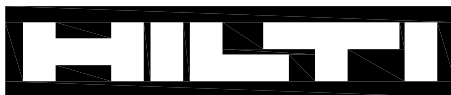

Hilti Firestop Systems

Reproduced by HILTI, Inc. Courtesy of
Underwriters Laboratories, Inc.
December 26, 2013

System No. F-A-5005



FA 5005

3B1. Sheathing Material — (Not shown) — Optionally, used in conjunction with Item 3B. Foil-scrim-kraft or all service jacket material shall be wrapped around the outer circumference of the pipe covering material (Item 3B) with the kraft side exposed. Longitudinal joints sealed with metal fasteners.

See Sheathing Materials (BVDV) category in the Building Materials Directory for names of manufacturers. Any sheathing material meeting the above specifications and bearing the UL Classification Marking with a Flame Spread value of 25 or less and a Smoke Developed value of 50 or less may be used.

The T Rating of the firestop system is dependent upon the thickness of the pipe covering material as shown in the table below:

Nom Thickness of Pipe Covering, mm	T Rating, Hr
38	3/4
25	1/2

4. Firestop System — The firestop system shall consist of the following:

A. Packing Material — Min 51 mm (2 in.) thickness of min 64 kg/m³ (4 pcf) mineral wool batt insulation tightly packed into opening as a permanent form. Packing material to be recessed from top surface of floor to accommodate the required thickness of fill material.

B. Fill, Void or Cavity Material* — Sealant Min 6 mm (1/4 in.) thickness of fill material applied within the annulus, flush with the top surface of floor.

HILTI CONSTRUCTION CHEMICALS, DIV OF HILTI INC — CP 604 Self-Leveling Firestop Sealant, CFS-S SIL GG or CFS-S SIL SL Sealant

*Bearing the UL Classification Mark



Hilti Firestop Systems

Reproduced by HILTI, Inc. Courtesy of
Underwriters Laboratories, Inc.
December 26, 2013