



Classified by
Underwriters Laboratories, Inc.
to CAN/ULC-S115

System No. FW-D-1001

F Rating — 2 Hr

FT Ratings — 1-3/4 Hr

FH Ratings — 2 Hr

FTH Ratings — 1-3/4 Hr

Nominal Joint Width — 152 mm (6 in.)

Class II Movement Capabilities — 10% Compression or Extension



FWD 1001

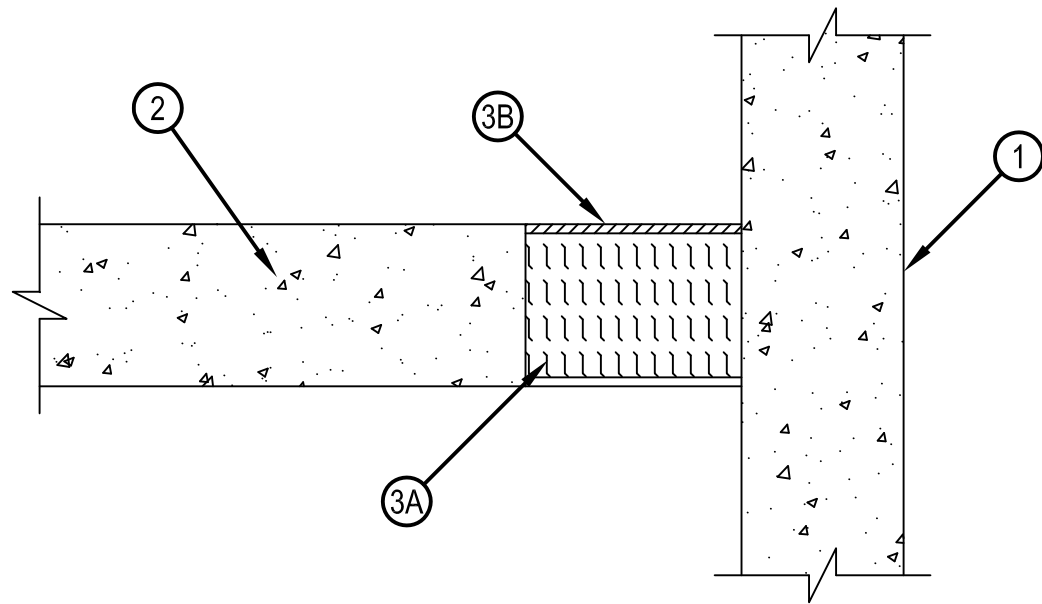

1. Wall Assembly — Min 114 mm (4-1/2 in.) thick reinforced lightweight or normal weight 1600-2400 kg/cu m (100-150 pcf) structural concrete. Wall may also be constructed of any UL Classified Concrete Blocks*.

See Concrete Blocks (CAZT) category in the Fire Resistance Directory for names of manufacturers.

2. Floor Assembly — Min 114 mm (4-1/2 in.) thick reinforced lightweight or normal weight 1600-2400 kg/cu m (100-150 pcf) structural concrete.

3. Joint System — Max separation between edge of floor and face of wall (at time of installation of joint system) is 152 mm (6 in.). The joint system is designed to accommodate a max 10 percent compression or extension from its installed width. The joint system shall consist of the following:

A. Forming Material — Min 64 kg/cu m (4 pcf) mineral wool batt insulation installed in joint opening as a permanent form. Pieces of batt cut to min width of 102 mm (4 in.) and installed edge first into joint opening, parallel with joint direction, such that batt sections are compressed min 50 percent in thickness and that the compressed batt sections are recessed a min of 6 mm (1/4 in.) from top surface of the floor to accommodate the required thickness of fill material. Adjoining lengths of batt to be tightly-butted with butted seams spaced min 610 mm (24 in.) apart along the length of the joint.

THERMAFIBER INC — Type SAF

B. Fill Void or Cavity Material* - Sealant — Min 6 mm (1/4 in.) thickness of fill material applied within the joint, flush with top surface of floor.

HILTI CONSTRUCTION CHEMICALS, DIV OF HILTI INC — CP604 Self-Leveling Firestop Sealant, CFS-S SIL GG or CFS-S SIL SL Sealant.

*Bearing the UL Classification Mark



Hilti Firestop Systems

Reproduced by HILTI, Inc. Courtesy of
Underwriters Laboratories, Inc.

December 19, 2013