

BLANK OPENING THROUGH GYPSUM WALL ASSEMBLY

F-RATING = 1-HR. OR 2-HR.

T-RATING = 0-HR. OR 1 3/4-HR.

L-RATING AT AMBIENT = LESS THAN 1 CFM / SQ FT

L-RATING AT 400°F = LESS THAN 1 CFM / SQ FT

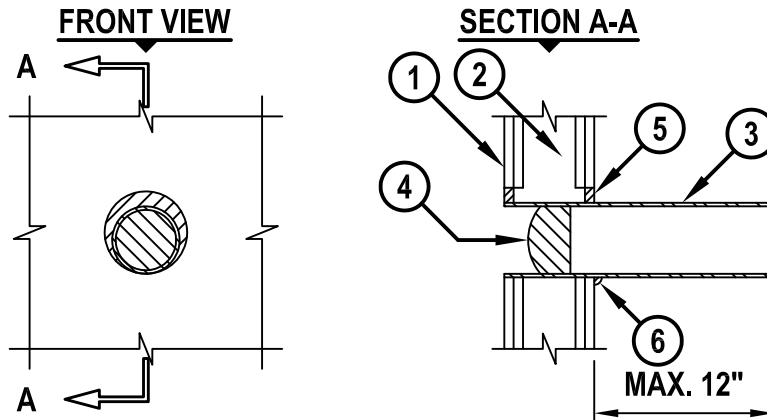

WL0019d.011015

1. GYPSUM WALL ASSEMBLY (UL/cUL CLASSIFIED U300, U400 OR V400 SERIES) (1-HR. OR 2-HR. FIRE-RATING) (2-HR. SHOWN).
2. [NOT SHOWN] WOOD STUDS TO CONSIST OF NOMINAL 2" x 4" LUMBER. STEEL STUDS TO BE MINIMUM 3-1/2" WIDE.
3. MAXIMUM 4" NOMINAL DIAMETER STEEL PIPE SLEEVE (SCHEDULE 5 OR HEAVIER). SLEEVE MAY EXTEND UP TO 12" BEYOND EITHER OR BOTH WALL SURFACE (SEE TABLE BELOW) (SEE NOTE NO. 3 BELOW).
4. HILTI CFS-PL FIRESTOP PLUG OR HILTI CP 658T FIRESTOP PLUG FRICTION FITTED WITHIN SLEEVE AND CENTERED WITHIN WALL.
5. MINIMUM 5/8" DEPTH HILTI FS-ONE MAX OR FS-ONE INTUMESCENT FIRESTOP SEALANT TO BE APPLIED WHEN ANNULAR SPACE EXISTS.
6. MINIMUM 1/2" BEAD HILTI FS-ONE MAX OR FS-ONE INTUMESCENT FIRESTOP SEALANT APPLIED AT SLEEVE/WALL INTERFACE WHEN SLEEVE EXTENDS PAST WALL.

SLEEVE/OPENING DIAM IN. (MM)	NOM PLUG SIZE, IN. (MM)	
	CP 658T	CFS-PL
1-1/2 (38)	2.5 (63) *	2 (51) *
2 (51)	2.5 (63) *	2 (51)
3 (76)	4 (102) *	4 (102) *
4 (102)	4 (102)	4 (102)

* CUT WEDGE FROM PLUG TO FIT SLEEVE/OPENING SIZE. SEE HILTI INSTALLATION INSTRUCTIONS FOR SPECIFIC SIZE OF WEDGE CUTS REQUIRED.

NOTES : 1. MAXIMUM DIAMETER OF OPENING = 5-1/2".
 2. ANNULAR SPACE = MINIMUM 0", MAXIMUM 1".
 3. SLEEVE TO BE RIGIDLY SUPPORTED WHEN EXTENDING MORE THAN 2" BEYOND WALL SURFACE.



HILTI, Inc.
 Tulsa, Oklahoma USA (800) 879-8000

Sheet	1 of 1
Scale	5/64" = 1"
Date	Jan. 10, 2015

Drawing No.
WL
0019d