



Classified by  
Underwriters Laboratories, Inc.  
to CAN/ULC-S115

# System No. F-B-1034

F Rating — 2 Hr

FT Ratings — 0 and 1/2 Hr (See Item 3)

FH Rating — 0 and 2 Hr (See Item 5)

FTH Ratings — 0 and 1/2 Hr (See Item 3 and 5)

L Rating At Ambient - Less Than 1 L/s per device

L Rating At 204°C- Less Than 1 L/s per device



FB 1034

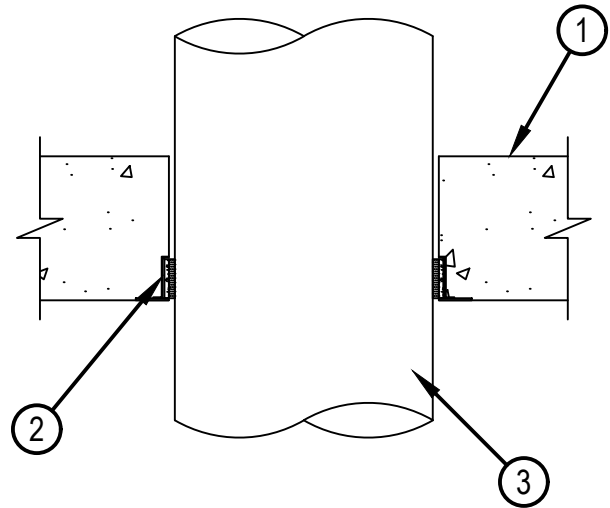
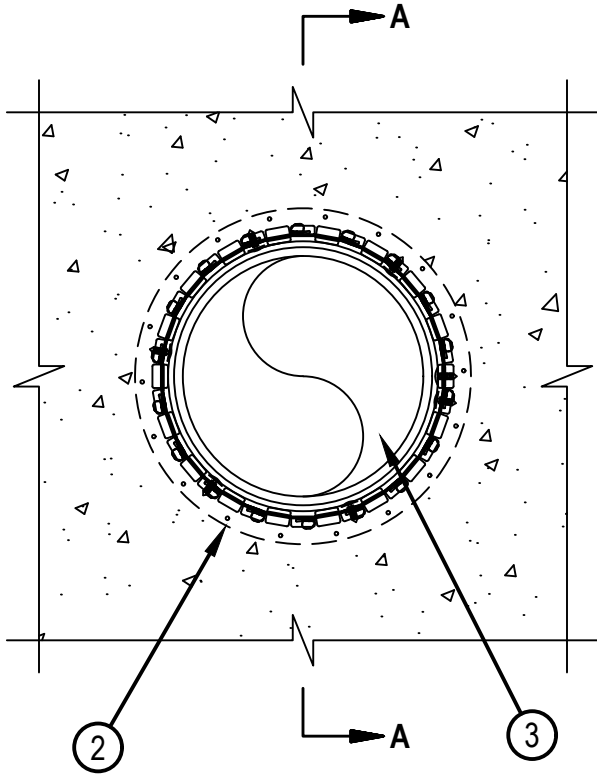

SECTION A-A



**Hilti Firestop Systems**

Reproduced by HILTI, Inc. Courtesy of  
Underwriters Laboratories, Inc.  
April 22, 2021

# System No. F-B-1034



FB 1034

1. Floor or Wall Assembly — Min 6 in. (152 mm) thick reinforced lightweight or normal weight (100-150 pcf or 1600-2400 kg/m<sup>3</sup>) concrete floor.
2. Firestop Device\* — Cast in place firestop device permanently embedded during the concrete pour or grouted into the concrete assembly in accordance with the accompanying installation instructions. Device to be sized for nom diam of through penetrant except as noted below.  
HILTI CONSTRUCTION CHEMICALS, DIV OF HILTI INC — CFS-CID M 10", CFS-CID M 8", CFS-CID P 8"
3. Through Penetrants — One metallic pipe to be installed within the firestop system. Pipe to be rigidly supported on both sides of the floor assembly. The following types and sizes of the metallic pipes may be used:
  - A. Steel Pipe — Nom 10 in. (254 mm) diam (or smaller) Schedule 40 (or heavier) steel pipe.
  - B. Iron Pipe — Nom 10 in. (254 mm) diam (or smaller) cast iron pipe.
  - C. Conduit — Nom 6 in. (152 mm) diam (or smaller) steel conduit.
  - D. Copper Tubing — Nom 4 in. (102 mm) diam (or smaller) Type L (or heavier) copper tubing.
  - E. Copper Pipe — Nom 4 in. (102 mm) diam (or smaller) Regular (or heavier) copper pipe.

The T, FT and FTH Ratings are dependent on the pipe diam and device used as noted in Table below. In addition, T, FT and FTH Ratings are 0 hr for copper pipe and tubes (Items 3D, 3E).

Max. Pipe Diam In. (mm) See Item 4.	Device	T, FT, FTH Rating	L Rating @ Ambient ++
10 (254 mm)	CFS-CID M 10"	1/2	Less Than 1 CFM per device Less Than 1 L/s per device
8 (203 mm)	CFS-CID M 8"	1/2	Less Than 1 CFM per device Less Than 1 L/s per device
8 (203 mm)	CFS-CID P 8"	0	1.47 CFM per device Less Than 1 L/s per device

++ For L Rating when the nom diam of pipe does not equal size of device, the mineral wool packing material (Item 4) is required.

4. Packing Material — When the nom pipe diam does not equal the device size, min 4 in. (102 mm) thickness of packing material shall be tightly packed within the annular space around the pipe flush with top of floor, or recessed from top of floor to accommodate the fill material (Item 5). When pipe diam equals device size, packing material is optional and min 2-1/2 in. (64 mm) thickness of min 4 pcf (64 kg/m<sup>3</sup>) mineral wool batt insulation may be firmly packed into top of opening as a permanent form. Packing material to be recessed from top surface of floor to accommodate the required thickness of fill material. Packing material shall not extend into the wrap strip layers.
5. Fill, Void or Cavity Material\* - Sealant — (Optional, not shown) — Min 1/2 in. (13 mm) thickness of fill material applied within the annulus, flush with top surface of floor. The FH and FTH Ratings are 0 hr when sealant is not used.  
HILTI CONSTRUCTION CHEMICALS, DIV OF HILTI INC — CP 601S, CFS-S SIL GG, CFS-S SIL SL Sealant or FS-ONE MAX Intumescent Sealant

\* Indicates such products shall bear the UL or cUL Certification Mark for jurisdictions employing the UL or cUL Certification (such as Canada), respectively.



**Hilti Firestop Systems**

Reproduced by HILTI, Inc. Courtesy of  
Underwriters Laboratories, Inc.  
April 22, 2021