



Classified by Underwriters Laboratories, Inc. to UL 1479 and CAN/ULC-S115

# System No. C-AJ-1630

ANSI/UL1479 (ASTM E814)	CAN/ULC S115
F Ratings — 2, 3 & 4 Hr (See Item 4)	F Rating — 2, 3 & 4 Hr (See Item 4)
T Rating — 0 Hr	FT Rating — 0 Hr
L Rating At Ambient — Less Than 1 CFM/sq ft	FH Rating — 2, 3 & 4 Hr (See Item 4)
L Rating At 400 F — Less Than 1 CFM/sq ft	FTH Rating — 0 Hr
W Rating — Class 1 (See Item 4)	L Rating At Ambient — Less Than 1 CFM/sq ft
	L Rating At 400 F — 4 CFM/sq ft

## CONFIGURATION A

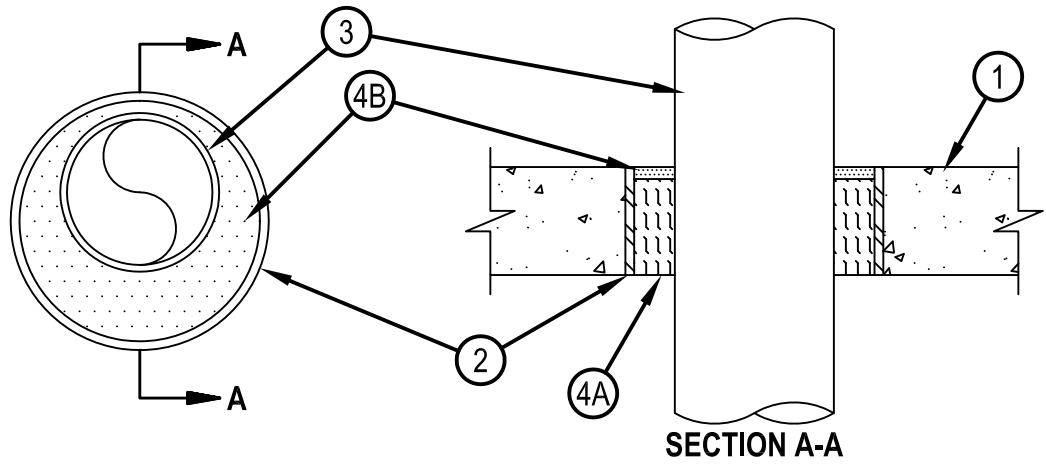

## CONFIGURATION B

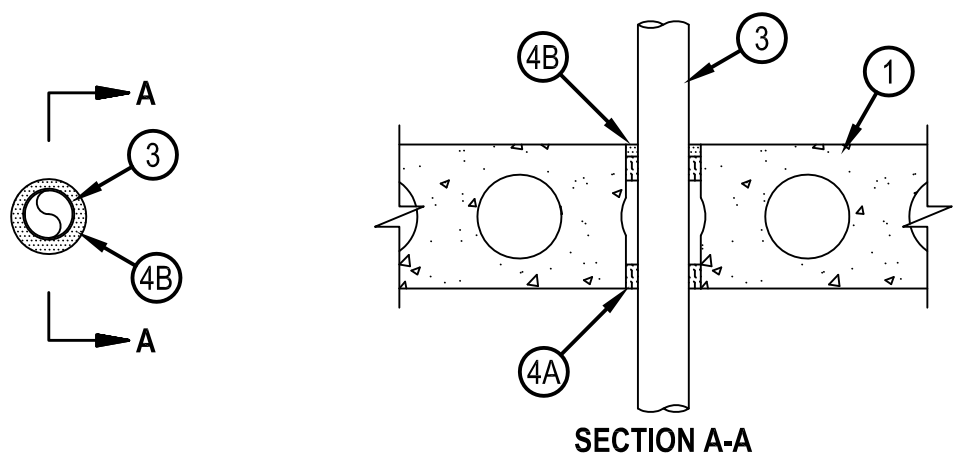

- 1. Floor or Wall Assembly — See Configuration A above. Reinforced lightweight or normal weight (100-150 pcf or 1600-2400 kg/cu meter) concrete as specified in the Table in Item 4 below. Wall may also be constructed of any UL Classified Concrete Blocks\*. Max diam of sleeved opening is 32 in. (813 mm).  
See Concrete Blocks (CAZT) category in the Fire Resistance Directory for names of manufacturers.
- 1A. Floor Assembly — See Configuration B above. Min 6 in. (152 mm) thick UL Classified hollow-core Precast Concrete Units\*. Max diam of opening is 7 in. (178 mm).  
See Precast Concrete Units (CFTV) category in the Fire Resistance Directory for names of manufacturers.



Reproduced by HILTI, Inc. Courtesy of Underwriters Laboratories, Inc. December 20, 2013

2. Steel Sleeve (Optional) — Nom 32 in. (813 mm) diam (or smaller) Schedule 10 (or heavier) steel pipe sleeve cast or grouted into floor or wall assembly, flush with both surfaces of floor or wall. As an option, sleeve may extend max 2 in. above top surface of floor or beyond one or both surfaces of wall. Steel sleeve may be used in 2 and 3 hr F Rated systems only.
3. Through Penetrants — One metallic pipe, conduit or tubing to be installed either concentrically or eccentrically within the firestop system. Pipe, conduit or tubing to be rigidly supported on both sides of floor or wall assembly. See Table in Item 4 for sizes of penetrants A, B, D and E that may be used. See Item 3C below for size of conduit that may be used. The annular space shall be as specified in Table in Item 4 below. The following types and sizes of metallic pipes, conduits or tubing may be used:
  - A. Steel Pipe — Schedule 10 (or heavier) steel pipe.
  - B. Iron Pipe — Cast or ductile iron pipe.
  - C. Conduit — Nom 4 in. (102 mm) diam (or smaller) steel electrical metallic tubing or nom 6 in. (152 mm) diam (or smaller) steel conduit.
  - D. Copper Tubing — Type L (or heavier) copper tubing.
  - E. Copper Pipe — Regular (or heavier) copper pipe.
4. Firestop System — The F Rating of the system is dependent upon the type of concrete, thickness of concrete, annular space, fill and packing material thickness, packing material density and penetrant size as shown in the Table below. W Rating applies to annular spaces of min 0 in. (point contact) to max 1-7/8 in. and to Configuration A detail only.

F Rating hr	Min Thick Concrete In. (mm)	Annular Space In. (mm)	Min Thick Packing Mtl In. (mm)	Min Density Packing Mtl pcf (kg/cu meter)	Min Thick Fill Mtl, In. (mm)	Penetrant Size, In. (mm) Diam (or Smaller)	
						D, E Copper	A, B (Steel Iron)
2	5-1/2 (140)	0 to 1-7/8 (0 to 48)	5 (127)	4 (64)	1/2 (13)	4 (102)	16 (406)
3	4-1/2 (114)	0 to 2-1/8 (0 to 54)	4-1/4 (108)	4 (64)	1/4 (6)	6 (152)	30 (762)
4	5-1/2 (140)	0 to 1-7/8 (0 to 48)	5 (127)	4 (64)	1/2 (13)	4 (102)	8 (203)

- A. Packing Material — Min 4-1/4 or 5 in. (108 or 127 mm) thickness of min 4.0 pcf (64 kg/cu meter) mineral wool batt insulation firmly packed into opening as a permanent form as specified in the Table above. Packing material to be recessed from top surface of floor or top end of sleeve, or from both surfaces of wall or ends of sleeve, as required to accommodate the required thickness of fill material. For hollow-core floor applications as shown in Configuration B, one half of the required thickness of mineral wool packing material shall be installed flush with the bottom surface of the floor and the remaining half of the mineral wool packing material installed at the top of the opening and recessed from the top surface of the floor to accommodate the required thickness of the fill material.
- B. Fill, Void or Cavity Material\* — Caulk — Min 1/4 or 1/2 in. (6 or 13 mm) thickness of fill material as specified in the Table above applied within the annulus, flush with top surface of floor or top end of sleeve, or with both surfaces of wall or ends of sleeve. At the point contact location between pipe and concrete or sleeve, a min 1/2 in. (13 mm) diam bead of fill material shall be applied. As an option, for hollow-core floors, the packing material (Item 4A) on the bottom surface of the floor may be recessed to accommodate a 1/4 in. (6 mm) depth of fill material installed flush with bottom surface of floor.

HILTI CONSTRUCTION CHEMICALS, DIV OF HILTI INC — CFS-S SIL GG (floors or walls) and CFS-S SIL SL (floors only)

\*Bearing the UL Classification Mark

