

PLASTIC PIPE THROUGH HOLLOW-CORE CONCRETE FLOOR ASSEMBLY

F-RATING = 3-HR.

FT-RATING = 0-HR. OR 1/2-HR.

FH-RATING = 3-HR.

FTH-RATING = 0-HR. OR 1/2-HR.

L-RATING AT AMBIENT = LESS THAN 1 CFM / SQ FT (SEE NOTE NO. 2 BELOW)

L-RATING AT 400°F = LESS THAN 1 CFM / SQ FT (SEE NOTE NO. 2 BELOW)

W-RATING = CLASS I (SEE NOTE NO. 2 BELOW)

NOTE : TESTED WITH A 50 Pa PRESSURE DIFFERENTIAL

cUL FB2051c.022714

TOP VIEW

SECTION A-A

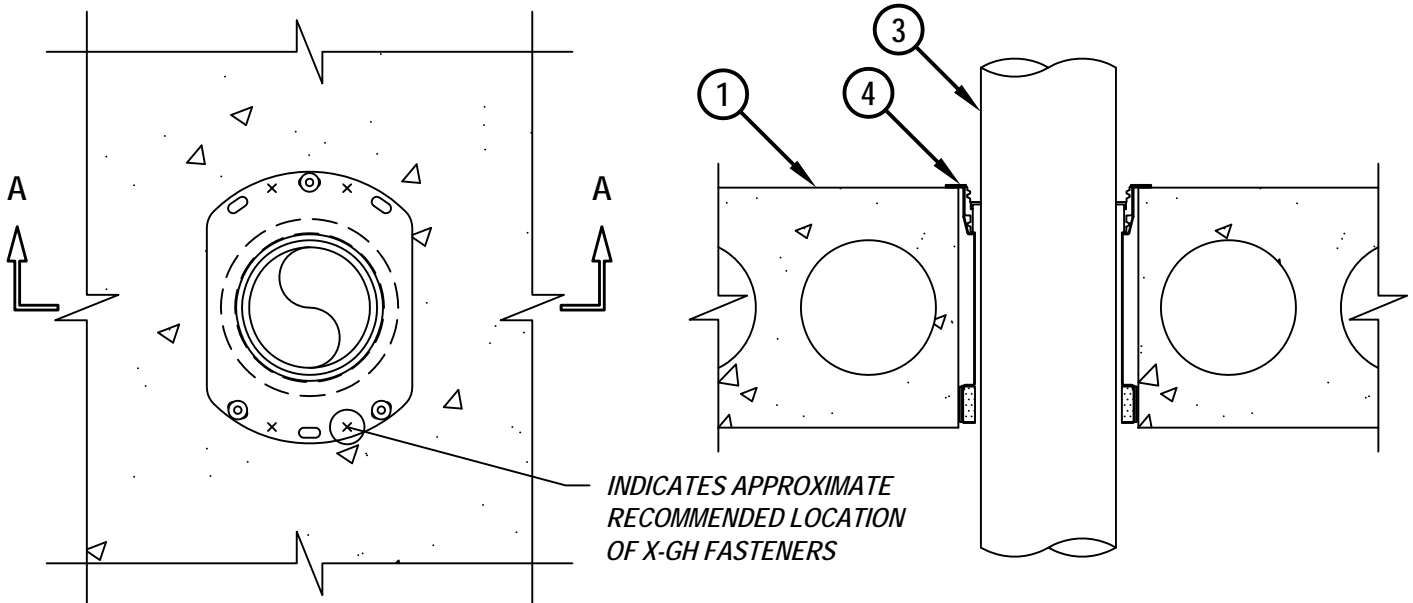

INDICATES APPROXIMATE RECOMMENDED LOCATION OF X-GH FASTENERS

1. ANY UL CLASSIFIED PRECAST HOLLOW-CORE FLOOR ASSEMBLY (MINIMUM 6" TO MAXIMUM 12-1/2" THICK) (3-HR. FIRE-RATING).
2. [OPTIONAL - NOT SHOWN] NOMINAL 4", 5", OR 6" DIAMETER GALVANIZED STEEL SLEEVE (MIN. 26 GA.), HAVING A MINIMUM 2" LAP ALONG THE LONGITUDINAL SEAM, INSERTED INTO THE OPENING. SLEEVE MAY EXTEND A MAXIMUM 4" BELOW BOTTOM SURFACE OF FLOOR AND SIT FLUSH WITH TOP SURFACE OF FLOOR.
3. PENETRATING ITEM TO BE ONE OF THE FOLLOWING :
 - A. MAXIMUM 4" NOMINAL DIAMETER PVC PLASTIC PIPE (CELLULAR OR SOLID CORE).
 - B. MAXIMUM 4" NOMINAL DIAMETER ABS PLASTIC PIPE (CELLULAR OR SOLID CORE).
 - C. MAXIMUM 4" NOMINAL DIAMETER CPVC PLASTIC PIPE.
 - D. MAXIMUM 4" NOMINAL DIAMETER FRPP PLASTIC PIPE.
 - E. MAXIMUM 4" NOMINAL DIAMETER AQUARISE CPVC PLASTIC PIPE (SDR 11) MANUFACTURED BY IPEX, INC. (CLOSED PIPING SYSTEM ONLY).
 - F. MAXIMUM 4" NOMINAL DIAMETER XFR 15/50 PVC PLASTIC PIPE (SOLID CORE).



HILTI, Inc.
Tulsa, Oklahoma USA (800) 879-8000

Sheet	1 of 2
Scale	5/32" = 1"
Date	Feb. 27, 2014

Drawing No.
**cUL
FB2051c**

PLASTIC PIPE THROUGH HOLLOW-CORE CONCRETE FLOOR ASSEMBLY

F-RATING = 3-HR.

FT-RATING = 0-HR. OR 1/2-HR.

FH-RATING = 3-HR.

FTH-RATING = 0-HR. OR 1/2-HR.

L-RATING AT AMBIENT = LESS THAN 1 CFM / SQ FT (SEE NOTE NO. 2 BELOW)

L-RATING AT 400°F = LESS THAN 1 CFM / SQ FT (SEE NOTE NO. 2 BELOW)

W-RATING = CLASS I (SEE NOTE NO. 2 BELOW)

NOTE : TESTED WITH A 50 Pa PRESSURE DIFFERENTIAL

cUL FB2051c.022714

4. HILTI CFS-DID FIRESTOP DROP-IN DEVICE INSERTED INTO OPENING (SEE TABLE BELOW) AND SECURED TO TOP OF FLOOR WITH THREE HILTI 1/4" (6mm) DIAMETER BY 1-1/4" (32mm) LONG KWIK-CON II+ CONCRETE SCREW ANCHORS, HILTI 1/4" (6mm) DIAMETER BY 1-3/4" (45mm) LONG KWIK BOLT 3 STEEL EXPANSION ANCHORS, OR HILTI 1/4" (6mm) BY 3/4" (19mm) LONG METAL HIT ANCHORS (INSTALLED IN A TRIANGULAR FASHION THROUGH HOLES PROVIDED). IN ADDITION, FOR NOMINAL 2", 3", AND 4" DEVICES, FOUR 11/16" (18mm) LONG HILTI X-GH P18 MX STEEL FASTENERS MAY BE INSTALLED THROUGH THE STEEL FLANGE, TWO ON EACH SIDE.

CORE HOLE OR SLEEVE DIAM	FIRESTOP DEVICE	NOM DIAM OF THROUGH PENETRANT	FLOOR THICKNESS (MIN. MAX.)
4"	CFS-DID 2" C	2" OR SMALLER+	6" to 6-1/2"
5"	CFS-DID 3" C	3"	6" to 6-1/2"
6"	CFS-DID 4" C	4"	6" to 6-1/2"
4"	CFS-DID 2" HC8	2" OR SMALLER+	7-1/2" to 8-1/2"
5"	CFS-DID 3" HC8	3"	7-1/2" to 8-1/2"
6"	CFS-DID 4" HC8	4"	7-1/2" to 8-1/2"
4"	CFS-DID 2" HC10	2" OR SMALLER+	9-1/2" to 10-1/2"
5"	CFS-DID 3" HC10	3"	9-1/2" to 10-1/2"
6"	CFS-DID 4" HC10	4"	9-1/2" to 10-1/2"
4"	CFS-DID 2" HC12	2" OR SMALLER+	11-1/2" to 12-1/2"
5"	CFS-DID 3" HC12	3"	11-1/2" to 12-1/2"
6"	CFS-DID 4" HC12	4"	11-1/2" to 12-1/2"

+ FOR PIPE SMALLER THAN NOMINAL 2" DIAMETER, AN ADAPTER AND HILTI IPS OR CPS TOP SEAL PLUG MUST BE USED IN CONJUNCTION WITH THE CFS-DID 2" C, HC8, HC10, AND HC12 DEVICES.

NOTES : 1. CLOSED OR VENTED PIPING SYSTEM (PVC, ABS, FRPP, XFR 15/50 PVC = SCH 40; CPVC = SDR 13.5).
 2. [OPTIONAL] TO ACHIEVE W-RATING AND/OR L-RATING, WATER BARRIER MODULES MAY BE THREADED ON TOP OF CFS-DID DEVICES FOR NOMINAL 2", 3", AND 4" PIPES (LISTED ABOVE).



HILTI, Inc.
 Tulsa, Oklahoma USA (800) 879-8000

Sheet	2 of 2
Scale	-
Date	Feb. 27, 2014

Drawing No.
**cUL
 FB2051c**