

**Design No. HI/BP 135-01**  
**PERIMETER FIRE BARRIER SYSTEM**

Hilti, Inc.  
**ASTM E 2307**

**Table 1**

	FIRESTOP JOINT SPRAY CFS-SP WB	SILICONE JOINT SPRAY CFS-SP SIL
F-RATING	2 1/4-HR.	2 1/4-HR.
T-RATING	2 1/4-HR.	2 1/4-HR.
APPLICATION THICKNESS	1/8" WET FILM (1/16" DRY)	2mm (0.079") WET FILM
CYCLING (%) HORIZONTAL VERTICAL SEE NOTE 1	± 12.5 ± 5	± 7.5 ± 5

**L-Rating <1.0 SCFM/LF**

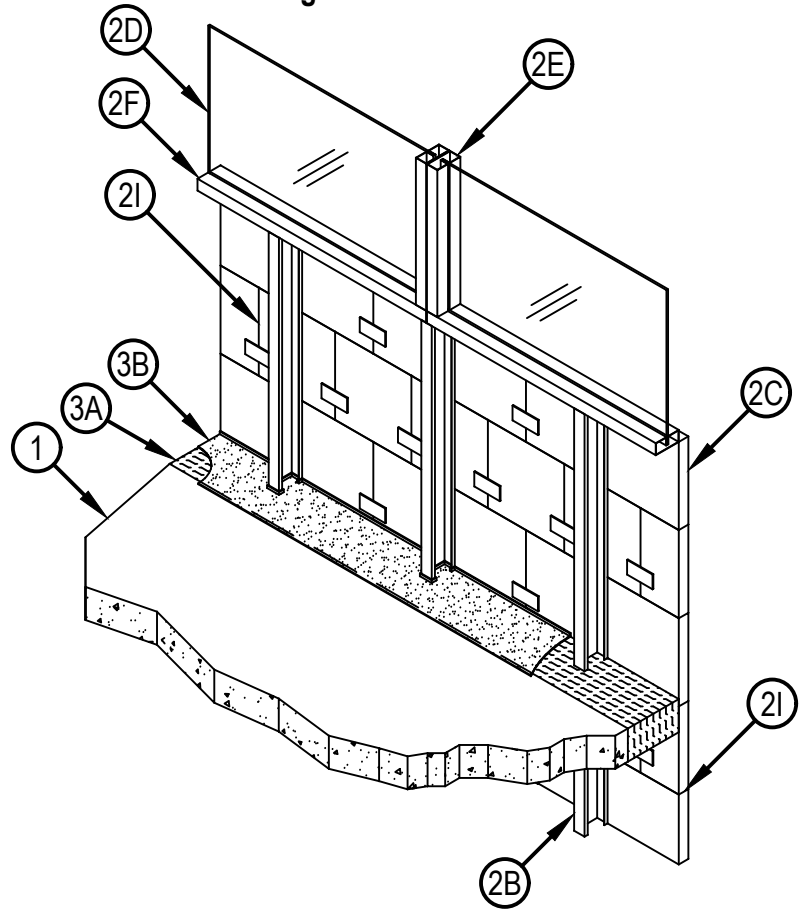

1. CONCRETE FLOOR ASSEMBLY: Two hour rated concrete floor assembly made from either lightweight or normal weight concrete with a density of 100-150 pcf, with a min. thickness of 4-1/2 in. at the joint face. Overall slab thickness may vary to accommodate various blockout depths (longitudinal recesses) formed in the concrete, to house the architectural cover plate. The blockout width may also vary without restriction.



**Hilti Firestop Systems**

Reproduced by HILTI, Inc.  
 Courtesy of Intertek Group  
 July 19, 2017



2. CURTAIN WALL ASSEMBLY: The concrete curtain wall assembly shall incorporate the following construction features:
- A. Mounting Attachment: (Not Shown) Attachment of the curtain wall framing to the structural framing shall be according to the curtain wall manufacturer's instructions. If required, mounting attachments to the floor slab shall be connected to the joint face of the floor slab. Max. distance between mounting attachments shall be 10ft..
  - B. Steel-Stud Framing: Vertical framing members shall be a min. 3-5/8 in. by 1-5/8 in., 18 GA steel "C" studs. Attachment shall be according to the curtain wall system manufacturer's guidelines. Vertical framing not to exceed a spacing of 56 in. on center and shall be completely covered by the concrete panels. If required, horizontal framing members shall be installed according to the curtain wall system manufacturer's guidelines.
  - C. Concrete Panels: Any non-combustible exterior concrete based panel. Panels shall not be less than 1-1/2 in. thick, 12 in. high or 12 in. long. Attachment to the framing shall be according to the curtain wall system manufacturer's guidelines.
  - D. Glass Vision Panels: Glass vision panels shall be at least 35-1/2 in. above the top surface of the floor assembly. Glass vision panels shall be installed to curtain wall framing according to the curtain wall system manufacturer's guidelines. Use a min. 1/4 in. thick, clear tempered glass with a max. width of 59 in. and height of 71 in.
  - E. Window Gaskets: Secure glass vision panels with a thermal break (thermal-set rubber extrusion).
  - F. Window Framing: Steel framing members shall be a min. 3-5/8 in. by 1-5/8 in. 18 GA steel "U" channel or similar construction that is compatible with steel-stud framing (2b). Locate window framing at least 35 in. above the top surface of the floor assembly.
  - G. Impaling Pins: (Not Shown - Optional) When required by insulation manufacturer, use with insulation. The pins shall be located, sized and installed according to the curtain wall system manufacturer's guidelines.
  - H. Curtain Wall Insulation: (Not Shown - Optional) When curtain wall insulation is used, the perimeter joint treatment must be installed before the insulation. Insulation may be butted to top and bottom of perimeter joint treatment but not deform the perimeter joint treatment. Either mineral wool\*\* or fiberglass batt insulation\*\* may be used. (\*\* Listed with Intertek)
  - I. Concrete Panel Joint: Vertical and horizontal concrete panel joints created between panels can be either flush type (butt joint) or key way type (tongue and groove). Concrete panel edges must be in contact with each other. If required, the surface of the panel joints can be sealed with gaskets or sealants.
  - J. Framing Covers: (Not Shown - Optional) Framing covers used over the mullions and transoms are optional. When used, the framing covers shall be located, sized and installed according to the curtain wall system manufacturer's guidelines. Framing covers do not pass through the perimeter joint treatment. They are butted to the top and bottom surfaces of the perimeter joint treatment without deforming it. Either mineral wool\*\* or fiberglass batt insulation\*\* may be used. (\*\* Listed with Intertek)
3. PERIMETER JOINT PROTECTION: The perimeter joint (linear opening) shall not exceed an 8 in. nom. joint width (joint width at installation) and the perimeter joint treatment shall incorporate the following construction features:
- A. Packing Material: Use a min. 4 in. thick, 4 pcf density, mineral wool batt insulation\*\* installed with the fibers running parallel to the slab edge and curtain wall. (\*\*Listed with Intertek) The packing material shall be compressed 50% in the nominal joint width. Compress the batt insulation into the perimeter joint such that the top surface of the batt insulation is flush with the top surface of the concrete floor slab. Splices (butt joints) in the lengths of mineral wool batt insulation are to be tightly compressed together. Reference the Introduction to Fire Resistive Joint Systems Section of this Directory for more details on how to determine the cut width of the insulation to be installed in the nominal joint width, and how to determine the compressed percentage of a known insulation width installed in a known nominal joint width.

**B. CERTIFIED MANUFACTURER: Hilti, Inc.**

CERTIFIED PRODUCT: Joint Spray or Sealant

MODEL: Firestop Joint Spray CFS-SP WB or Silicone Joint Spray CFS-SP SIL

Fill, Void or Cavity Material: To be applied, (sprayed, brushed, or painted) to cover the exposed surface of the mineral wool installed in the perimeter joint. Apply at the thickness specified in Table 1 and overlap the material a min. 1/2 in. onto the adjacent curtain wall assembly and concrete floor slab assembly. If the spraying process is stopped and the applied liquid cures to an elastomeric film before process is restarted, then overlap the edge of the cured material at least 1/8 in. with the spray. Reference Product Section of this Directory for more details about the Listed product.

- C. Support Clips: (Not Shown - Optional) Use standard Z-shaped clips that are min. 20 GA galvanized steel with the following nom. dimensions: 1 in. wide by 3 in. high with a 2 in. upper leg and 3 in. lower leg.

\*\* Cycling: Before testing, the spliced, test specimen was cycled 500 times at 30 cpm in accordance with ICBO ES AC 30 (Jan. 1997) and ASTM E 1966.



**Hilti Firestop Systems**

Reproduced by HILTI, Inc.  
Courtesy of Intertek Group  
July 19, 2017

**Intertek**