



Classified by
Underwriters Laboratories, Inc.
to CAN/ULC-S115

System No. W-L-2565

F Rating - 1 and 2 Hr (See Item 1)

T Rating - 0 Hr

FT Rating - 0 Hr

FTH Rating - 0 Hr



W-L-2565

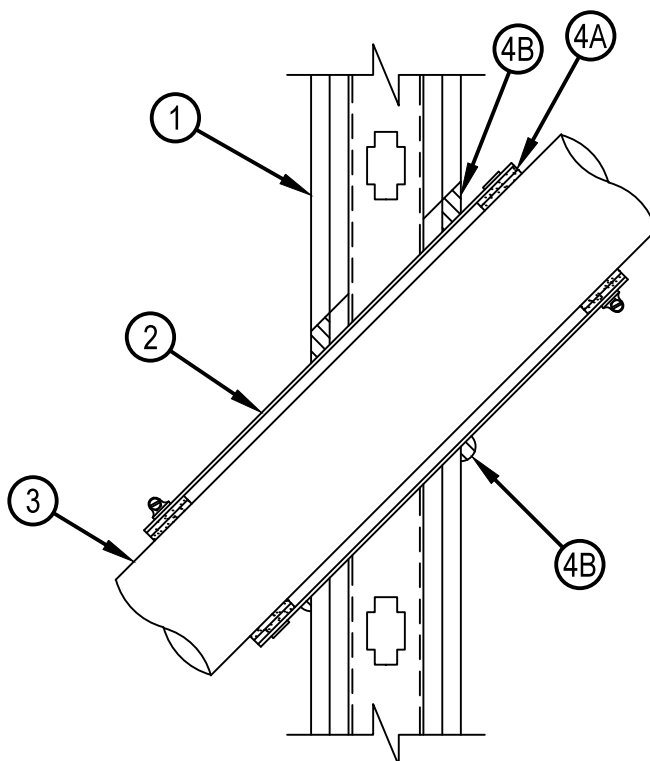

System tested with a pressure differential of 50 Pa between the exposed and the unexposed surfaces with the higher pressure on the exposed side.

1. Wall Assembly — The 1 and 2 hr fire rated gypsum board/stud wall assembly shall be constructed of the materials and in the manner described in the individual U400, V400 or W400 Series Wall and Partition Design in the UL Fire Resistance Directory and shall include the following construction features:
 - A. Studs — Wall framing shall consist of steel channel studs. Steel studs to be min 64 mm (2-1/2 in.) wide and spaced max 610 mm (24 in.) OC.
 - B. Gypsum Board* — The gypsum board type, thickness number of layers, fastener type and sheet orientation shall be specified in the individual Wall and Partition Design in the UL Fire Resistance Directory. Max diam of opening is 152 mm (6 in.). The hourly F Rating of the firestop system is equal to the hourly fire rating of the wall assembly in which it is installed.
2. Steel Sleeve — Nom 133 mm (5-1/4 in.) diam cylindrical sleeve fabricated from 0.4 mm (0.016 in.) thick (No 28 gauge) galv sheet steel and having a min 25 mm (1 in.) lap along longitudinal seam. Sleeve to extend 51 mm (2 in.) beyond each surface of wall. The sleeve shall be compressed around the pipe (Item 3) and wrap strip (Item 4A) using 13 mm (1/2 in.) wide by 0.7 mm (0.028 in.) thick stainless steel band clamps fastened at the center of wrap strip. The annular space between the sleeve the periphery of the opening shall be a min 0 mm (point contact) to max 19 mm (3/4 in.).



Hilti Firestop Systems

Reproduced by HILTI, Inc. Courtesy of
Underwriters Laboratories, Inc.

January 26, 2015

3. Through-Penetrants — One nonmetallic pipe to be installed concentrically or eccentrically within the firestop system. Pipe may be installed at an angle not greater than 45 degrees from perpendicular. Pipe to be rigidly supported on both sides of wall assembly. The following types and sizes of nonmetallic pipes may be used:
- A. Acrylonitrile Butadiene Styrene (ABS) Pipe — Nom 102 mm (4 in.) diam (or smaller) Schedule 40 solid or cellular core ABS pipe for use in closed (process or supply) or vented (drain, waste or vent) piping systems.
 - B. Polyvinyl Chloride (PVC) Pipe — Nom 102 mm (4 in.) diam (or smaller) Schedule 40 solid or cellular PVC core pipe for use in closed (process or supply) or vented (drain, waste or vent) piping systems.
 - C. Chlorinated Polyvinyl Chloride (CPVC) Pipe — Nom 102 mm (4 in.) diam (or smaller) SDR13.5 CPVC pipe. CPVC pipe for use in closed (process or supply) piping systems.
4. Firestop System — The firestop system shall consist of the following:
- A. Fill, Void or Cavity Material - Wrap Strip — Nom 4.8 mm (3/16 in.) thick by 44 mm (1-3/4 in.) wide intumescent wrap strip. Two layers of wrap strip continuously wrapped around the pipe and held in place with tape. Wrap strip is installed within the steel sleeve on each side of the wall, flush with ends of sleeve.
HILTI CONSTRUCTION CHEMICALS, DIV OF HILTI INC — CP648-E W45/1-3/4 Wrap Strip
 - B. Fill, Void or Cavity Material - Sealant* — Min 16 mm (5/8 in.) thickness of fill material applied within annulus between concrete and steel sleeve, flush with surface of wall. At point contact, a min 13 mm (1/2 in.) bead of fill material shall be applied at the concrete/steel sleeve interface on both sides of wall.
HILTI CONSTRUCTION CHEMICALS, DIV OF HILTI INC — FS-ONE Sealant or FS-ONE MAX Intumescent Sealant.
- * Indicates such products shall bear the UL or cUL Certification Mark for jurisdictions employing the UL or cUL Certification (such as Canada), respectively.

