

PLASTIC PIPE THROUGH GYPSUM WALL ASSEMBLY

F, FT, FH AND FTH-RATINGS = 1-HR. OR 2-HR.

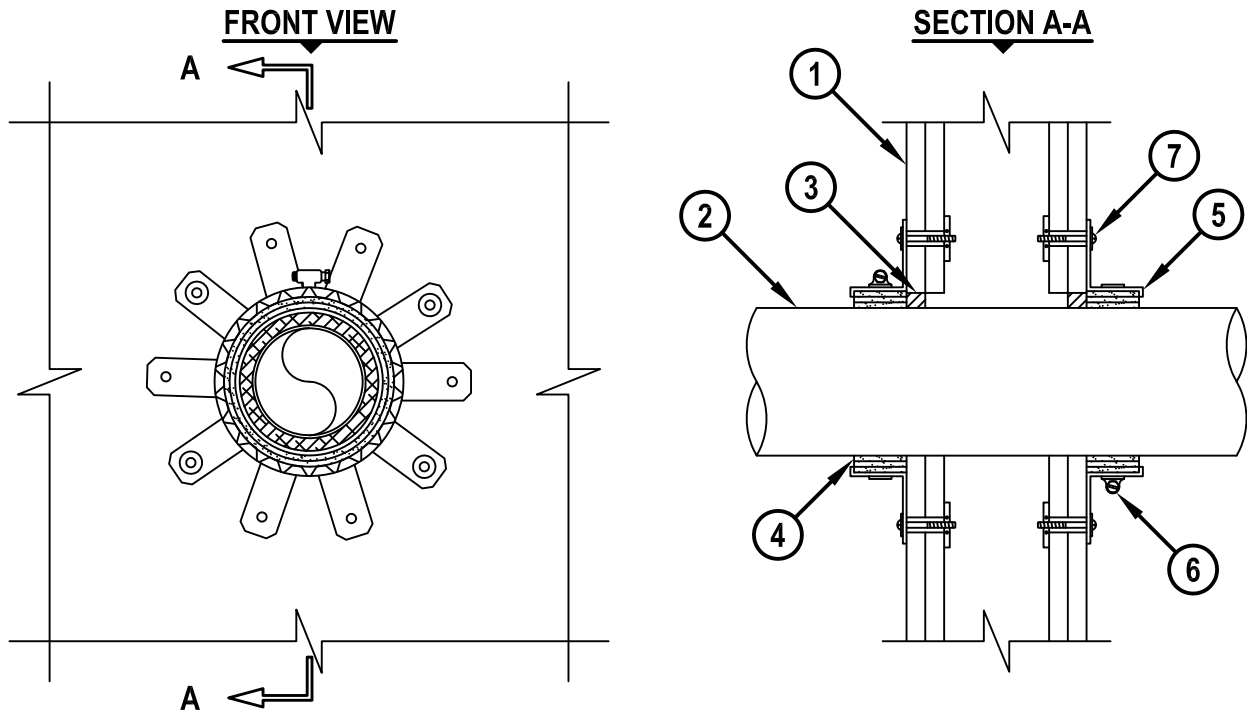

cUL WL2052b.011615

1. GYPSUM WALL ASSEMBLY (UL/cUL CLASSIFIED U300, U400, OR V400 SERIES) (1-HR. OR 2-HR. FIRE-RATING) (2-HR. SHOWN) TO INCLUDE THE FOLLOWING CONSTRUCTION FEATURES :
 - A. [NOT SHOWN] WOOD STUDS TO CONSIST OF NOMINAL 2" x 4" LUMBER (SPACED MAXIMUM 16" OC). STEEL STUDS TO BE MINIMUM 3-1/2" WIDE (SPACED MAXIMUM 24" OC).
 - B. NOMINAL 5/8" THICK GYPSUM WALLBOARD. TYPE, NUMBER OF LAYERS, AND SHEET ORIENTATION AS SPECIFIED IN THE INDIVIDUAL UL DESIGN.
2. PENETRATING ITEM TO BE ONE OF THE FOLLOWING :
 - A. MAXIMUM 4" NOMINAL DIAMETER POLYPROPYLENE (PP) SDR 11 PLASTIC PIPE (CLOSED PIPING SYSTEM ONLY).
 - B. MAXIMUM 125mm FUSIOTHERM® (SDR 11 OR SDR 7.4 WITH FASER) PP PLASTIC PIPE MANUFACTURED BY AQUATHERM, INC. (CLOSED PIPING SYSTEM ONLY).
3. MINIMUM 5/8" DEPTH HILTI FS-ONE MAX OR FS-ONE INTUMESCENT FIRESTOP SEALANT FLUSH WITH EACH SIDE OF WALL.
4. HILTI CP 648E WRAP STRIP (NOMINAL 3/16" THICK x 1-3/4" WIDE) CONTINUOUSLY WRAPPED AROUND THE OUTER CIRCUMFERENCE OF THE PIPE, COVERING THREE TIMES, WITH ENDS BUTTED AND HELD IN PLACE WITH TAPE. WRAP STRIP TO BE BUTTED TIGHTLY AGAINST BOTH SURFACES OF GYPSUM WALL.
5. HILTI 1-3/4" RETAINING COLLAR WRAPPED OVER THE WRAP STRIPS, OVERLAPPING MINIMUM 1".
6. NOMINAL 1/2" WIDE STAINLESS STEEL HOSE CLAMP FASTENED AT MID-HEIGHT OF RETAINING COLLAR.
7. MINIMUM 4 TABS OF RETAINING COLLAR (SYMMETRICALLY SPACED) SECURED TO BOTH SIDES OF GYPSUM WALL WITH 1/4" DIAMETER LONG STEEL TOGGLE BOLTS WITH 3/4" DIAMETER STEEL WASHERS.

NOTES : 1. MAXIMUM DIAMETER OF OPENING = 5-1/2".
 2. ANNULAR SPACE = MINIMUM 0", MAXIMUM 1/2".

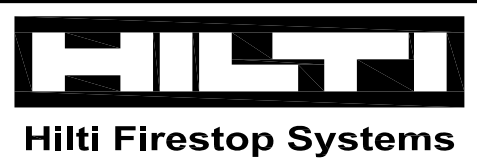

HILTI, Inc.
 Tulsa, Oklahoma USA (800) 879-8000

Sheet	1 of 1
Scale	5/32" = 1"
Date	Jan. 16, 2015

Drawing No.
cUL
WL2052b