

INSTALL PER UL SYSTEM W-L-1054
USE HILTI FS-ONE MAX FIRESTOP SEALANT

METAL PIPE	
TYPE	MAX. DIA.
STEEL PIPE (SCH. 10 OR HEAVIER)	30"
CAST IRON PIPE	30"
COPPER PIPE	6"
STEEL CONDUIT	6"
EMT	4"

1 METAL PIPE THROUGH GYPSUM WALL ASSEMBLY (2-HR.)
E.4.3 NOT TO SCALE

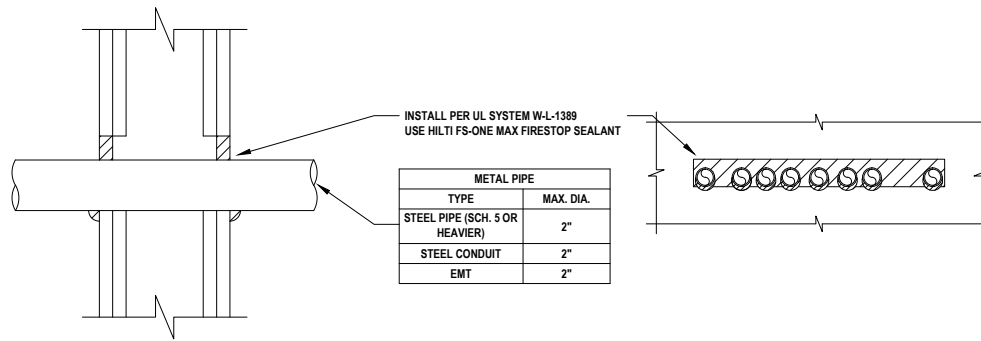

INSTALL PER UL SYSTEM W-L-1389
USE HILTI FS-ONE MAX FIRESTOP SEALANT

METAL PIPE	
TYPE	MAX. DIA.
STEEL PIPE (SCH. 5 OR HEAVIER)	2"
STEEL CONDUIT	2"
EMT	2"

2 MULTIPLE METAL PIPES THROUGH GYPSUM WALL ASSEMBLY (2-HR.)
E.4.3 NOT TO SCALE

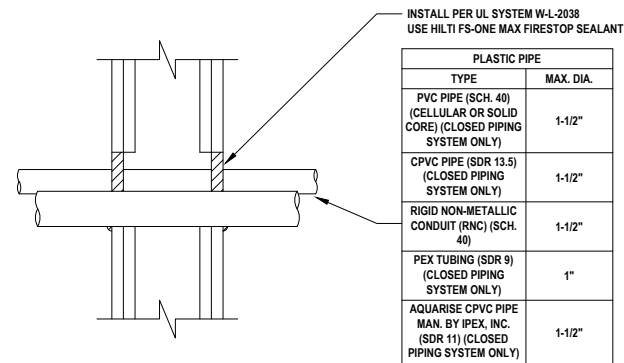

INSTALL PER UL SYSTEM W-L-2038
USE HILTI FS-ONE MAX FIRESTOP SEALANT

PLASTIC PIPE	
TYPE	MAX. DIA.
PVC PIPE (SCH. 40) (CELLULAR OR SOLID CORE) (CLOSED PIPING SYSTEM ONLY)	1-1/2"
CPVC PIPE (SDR 13.5) (CLOSED PIPING SYSTEM ONLY)	1-1/2"
RIGID NON-METALLIC CONDUIT (RNC) (SCH. 40)	1-1/2"
PEX TUBING (SDR 9) (CLOSED PIPING SYSTEM ONLY)	1"
AQUARISE CPVC PIPE MAN. BY IPEX, INC. (SDR 11) (CLOSED PIPING SYSTEM ONLY)	1-1/2"

3 MULTIPLE PLASTIC PIPES THROUGH GYPSUM WALL ASSEMBLY (2-HR.)
E.4.3 NOT TO SCALE

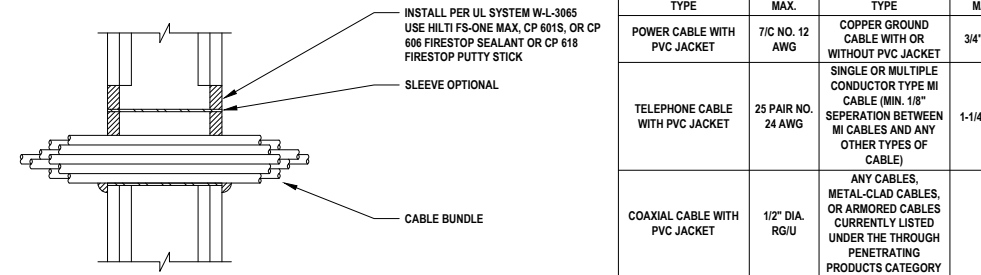

INSTALL PER UL SYSTEM W-L-3065
USE HILTI FS-ONE MAX, CP 601S, OR CP 606 FIRESTOP SEALANT OR CP 618 FIRESTOP PUTTY STICK

SLEEVE OPTIONAL

CABLE BUNDLE

CABLE BUNDLE CONSISTS OF:			
TYPE	MAX.	TYPE	MAX.
POWER CABLE WITH PVC JACKET	7/C NO. 12 AWG	COPPER GROUND CABLE WITH OR WITHOUT PVC JACKET	3/4" DIA.
TELEPHONE CABLE WITH PVC JACKET	25 PAIR NO. 24 AWG	SINGLE OR MULTIPLE CONDUCTOR TYPE MI CABLE (MIN. 1/8" SEPERATION BETWEEN MI CABLES AND ANY OTHER TYPES OF CABLE)	1-1/4" DIA.
COAXIAL CABLE WITH PVC JACKET	1/2" DIA. RG/U	ANY CABLES, METAL-CLAD CABLES, OR ARMORED CABLES CURRENTLY LISTED UNDER THE THROUGH PENETRATING PRODUCTS CATEGORY	-
METAL-CLAD CABLE	3/C NO. 8 AWG	ALUMINUM SER CABLE	4/C (+GROUND) NO. 300 KCMIL
COPPER CONDUCTOR CABLE (ROMEX)	3/C (+GROUND) NO. 8 AWG	CABLE	4 PAIR NO. 22 AWG CAT 5 OR CAT 6
FIBER OPTIC CABLE WITH PVC JACKET	5/8" DIA.	COAXIAL CABLE WITH FLUORINATED ETHYLENE JACKET	RG 6/U

4 CABLE BUNDLE THROUGH GYPSUM WALL ASSEMBLY (2-HR.)
E.4.3 NOT TO SCALE

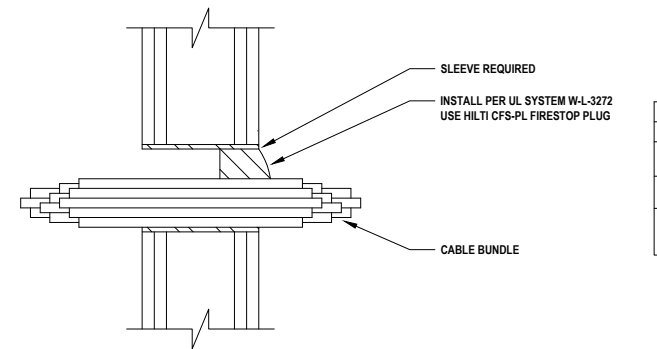

SLEEVE REQUIRED
INSTALL PER UL SYSTEM W-L-3272
USE HILTI CFS-PL FIRESTOP PLUG

CABLE BUNDLE CONSISTS OF:			
TYPE	MAX.	TYPE	MAX.
TELEPHONE CABLE WITH PVC JACKET	300 PAIR NO. 24 AWG	FIBER OPTIC CABLE (MAX. 24 FIBER)	1/2" DIA.
POWER CABLE WITH PVC JACKET	750 KCMIL	METAL-CLAD CABLE WITH PVC JACKET	3/C NO. 12 AWG
POWER CABLE WITH PVC JACKET	7/C NO. 12 AWG	METAL-CLAD TEK CABLE WITH PVC JACKET	1"

5 CABLE BUNDLE THROUGH GYPSUM WALL ASSEMBLY (2-HR.)
E.4.3 NOT TO SCALE

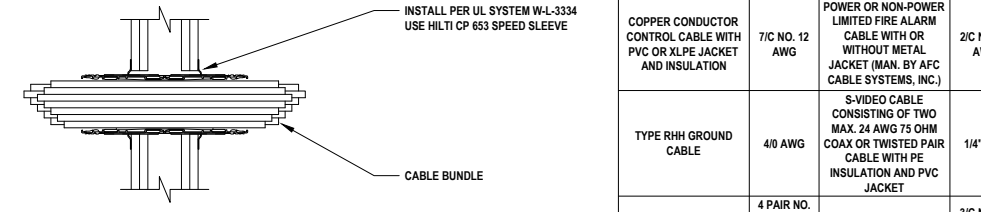

INSTALL PER UL SYSTEM W-L-3334
USE HILTI CP 653 SPEED SLEEVE

CABLE BUNDLE

CABLE BUNDLE CONSISTS OF:			
TYPE	MAX.	TYPE	MAX.
TELEPHONE CABLE WITH PVC JACKET	100 PAIR NO. 24 AWG	SHIELDED PRINTER CABLE WITH PVC JACKET	20/C NO. 22 AWG
COPPER CONDUCTOR CONTROL CABLE WITH PVC OR XLPE JACKET AND INSULATION	7/C NO. 12 AWG	POWER OR NON-POWER LIMITED FIRE ALARM CABLE WITH OR WITHOUT METAL JACKET (MAN. BY AFC CABLE SYSTEMS, INC.)	2/C NO. 18 AWG
TYPE RHH GROUND CABLE	4/0 AWG	S-VIDEO CABLE CONSISTING OF TWO MAX. 24 AWG 75 OHM COAX OR TWISTED PAIR CABLE WITH PE INSULATION AND PVC JACKET	1/4" DIA.
COMPUTER CABLE	4 PAIR NO. 22 AWG CAT 5 OR CAT 6	METAL-CLAD CABLE	3/C NO. 12 AWG
COAXIAL CABLE	RG 6/U	ANY CABLES, METAL-CLAD CABLES, OR ARMORED CABLES CURRENTLY LISTED UNDER THE THROUGH PENETRATING PRODUCTS CATEGORY	-
FIBER OPTIC CABLE (24 FIBER) WITH PVC OR PE JACKET AND INSULATION	1/2" DIA.		

6 CABLE BUNDLE THROUGH GYPSUM WALL ASSEMBLY (2-HR.)
E.4.3 NOT TO SCALE

Notes:

1. Refer to the following specifications for firestopping.
 - a. 07 84 00 Firestopping
 - b. 07 84 13 Penetration Firestopping
 - c. 22 00 00 Plumbing
 - d. 23 00 00 HVAC
 - e. 26 00 00 Electrical
 - f. 27 06 37 Communication

For Quality Control requirements, refer to the Quality Control portion of the specification.

2. Details shown are typical details, containing general information only. Always refer to the full UL system detail for complete system requirements. If field conditions do not match requirements of details, approved alternate details shall be utilized. Design requirements, field conditions and dimensions need to be verified for compliance with the details, including but not limited to the following:
 - * Fire Rating (F-Rating)
 - * Temperature Rating (T-Rating)
 - * Leakage Rating (L-Rating)
 - * Water Rating (W-Rating)
 - * Annular Space
 - * Percent Fill
 - * Movement
 - * Type and thickness of fire-rated construction.

3. If alternate details matching the field conditions are not available, manufacturer's engineering judgment drawings are acceptable. Contact Hilti Inc. for alternative systems or Engineering Judgment (800-879-8000) Drawings shall follow the International Firestop Council (IFC) Guidelines for Evaluating Firestop Systems Engineering Judgments.

4. References:
 - * 2013 Underwriter's Laboratories Fire Resistance Directory, Volumes 1 & 2
 - * NFPA 101 Life Safety Code
 - * NFPA 70 - National Electric Code
 - * All governing local and regional building codes

5. Firestop System installation must meet requirements of ASTM E-814 (UL 1479) tested assemblies that provide a fire rating equal to that of construction being penetrated.

6. All rated through-penetration assemblies shall be prominently labeled with a Hilti Firestop Label equipped with a QR code with the following information:
 - * Warning! - Do Not Disturb
 - * Through Penetration Firestop System
 - * UL System # * Product(s) used
 - * Hourly Rating (F-Rating)
 - * Installation Date
 - * Contractor's Name

7. For outlet boxes requiring protection, use only Wall Opening Protective Materials, category CLIV as classified by Underwriter's Laboratories, Fire Resistance Directory (Volume 1.)

<Notes to designer (delete this note after reading and replace with title block information)>
 1. Any modification to these details could result in an application/system not meeting the UL or Intertek Classification or the intended temperature or fire ratings.
 2. Details shown are up to date as of February 2015.
 3. For additional information on the details, refer to the most current "Underwriter's Laboratories Fire Resistance Directory (volume 2)."

JOB NUMBER: _____

CHECKED: _____

ISSUE DATE: _____

REVISIONS: _____

CONTENTS: _____

ELECTRICAL PENETRATIONS
GYPSUM WALL
2 HR.

SHEET NAME: _____

E.4.3

SHEET NUMBER: _____

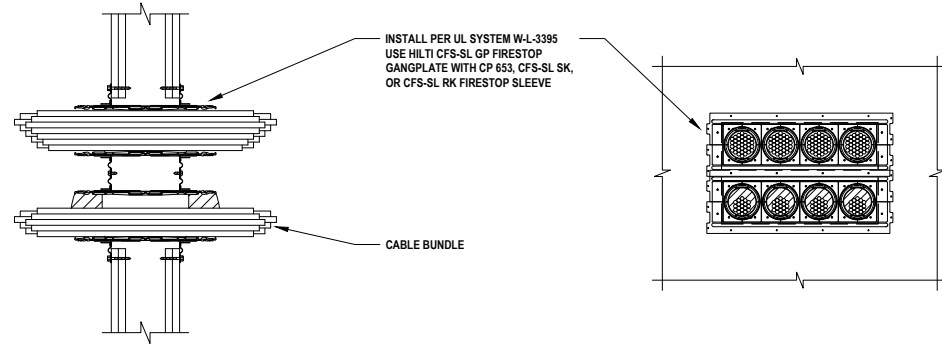

CABLE BUNDLE CONSISTS OF:			
TYPE	MAX.	TYPE	MAX.
TELEPHONE CABLE WITH PVC JACKET	100 PAIR NO. 24 AWG	COAXIAL CABLE	RG 6/U
COPPER CONDUCTOR CONTROL CABLE WITH PVC OR XLPE JACKET AND INSULATION	7/C NO. 12 AWG	FIBER OPTIC CABLE (24 FIBER) WITH PVC OR PE JACKET AND INSULATION	1/2" DIA.
TYPE RHH GROUND CABLE	4/0 AWG	MC CABLE	3/C NO. 12 AWG
COMPUTER CABLE	4 PAIR NO. 22 AWG CAT 5 OR CAT 6		

1 MULTIPLE CABLE BUNDLES THROUGH GYPSUM WALL ASSEMBLY (2-HR.)
E.4.4 NOT TO SCALE

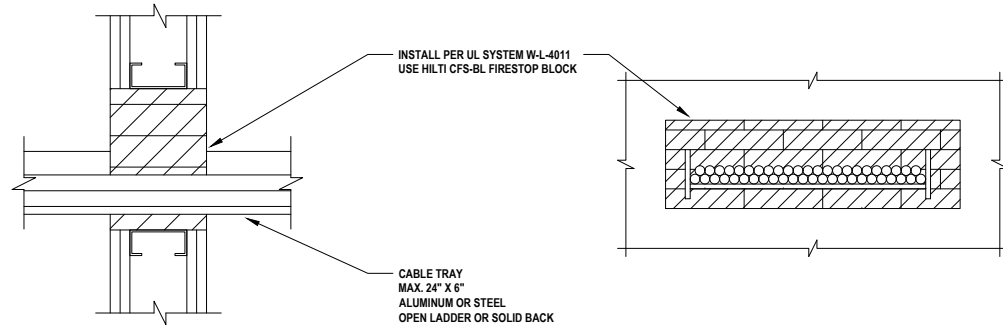

CABLE BUNDLE CONSISTS OF:			
TYPE	MAX.	TYPE	MAX.
TELEPHONE CABLE	300 PAIR NO. 24 AWG	FIBER OPTIC CABLE (24 FIBER)	1/2" DIA.
SINGLE CONDUCTOR POWER CABLE	750 KCMIL	METAL-CLAD CABLE	3/C NO. 12 AWG

2 CABLE TRAY THROUGH GYPSUM WALL ASSEMBLY (2-HR.)
E.4.4 NOT TO SCALE

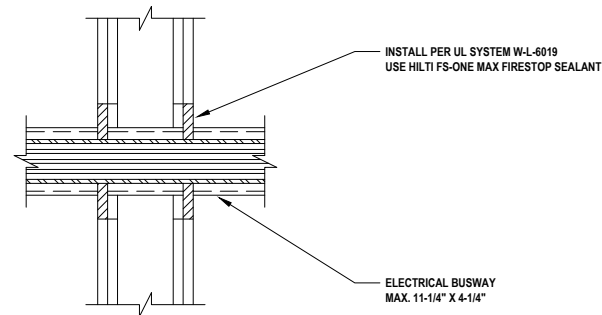

3 ELECTRICAL BUSWAY THROUGH GYPSUM WALL ASSEMBLY (2-HR.)
E.4.4 NOT TO SCALE

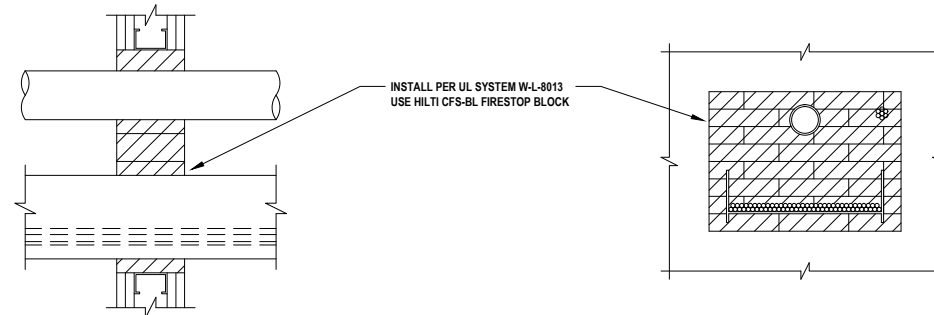

4 MULTIPLE PENETRATIONS THROUGH GYPSUM WALL ASSEMBLY (2-HR.)
E.4.4 NOT TO SCALE

Notes:

1. Refer to the following specifications for firestopping.
 - a. 07 84 00 Firestopping
 - b. 07 84 13 Penetration Firestopping
 - c. 22 00 00 Plumbing
 - d. 23 00 00 HVAC
 - e. 26 00 00 Electrical
 - f. 27 06 37 Communication

For Quality Control requirements, refer to the Quality Control portion of the specification.

2. Details shown are typical details, containing general information only. Always refer to the full UL system detail for complete system requirements. If field conditions do not match requirements of details, approved alternate details shall be utilized. Design requirements, field conditions and dimensions need to be verified for compliance with the details, including but not limited to the following:

- * Fire Rating (F-Rating)
- * Temperature Rating (T-Rating)
- * Leakage Rating (L-Rating)
- * Water Rating (W-Rating)
- * Annular Space
- * Percent Fill
- * Movement
- * Type and thickness of fire-rated construction.

3. If alternate details matching the field conditions are not available, manufacturer's engineering judgment drawings are acceptable. Contact Hilti Inc. for alternative systems or Engineering Judgment (800-879-8000) Drawings shall follow the International Firestop Council (IFC) Guidelines for Evaluating Firestop Systems Engineering Judgments.

4. References:

- * 2013 Underwriter's Laboratories Fire Resistance Directory, Volumes 1 & 2
- * NFPA 101 Life Safety Code
- * NFPA 70 - National Electric Code
- * All governing local and regional building codes

5. Firestop System installation must meet requirements of ASTM E-814 (UL 1479) tested assemblies that provide a fire rating equal to that of construction being penetrated.

6. All rated through-penetration assemblies shall be prominently labeled with a Hilti Firestop Label equipped with a QR code with the following information:

- * Warning! - Do Not Disturb
- * Through Penetration Firestop System
- * UL System # * Product(s) used
- * Hourly Rating (F-Rating)
- * Installation Date
- * Contractor's Name

7. For outlet boxes requiring protection, use only Wall Opening Protective Materials, category CLIV as classified by Underwriter's Laboratories, Fire Resistance Directory (Volume 1.)

<Notes to designer (delete this note after reading and replace with title block information)>
 1. Any modification to these details could result in an application/system not meeting the UL or Intertek Classification or the intended temperature or fire ratings.
 2. Details shown are up to date as of February 2015.
 3. For additional information on the details, refer to the most current "Underwriter's Laboratories Fire Resistance Directory (volume 2)."
 </Notes to designer (delete this note after reading and replace with title block information)>

JOB NUMBER: _____

CHECKED: _____

ISSUE DATE: _____

REVISIONS: _____

CONTENTS: _____

ELECTRICAL PENETRATIONS
GYPSUM WALL
2 HR.

SHEET NAME: _____

E.4.4

SHEET NUMBER: _____