

1 METAL PIPE THROUGH CONCRETE FLOOR (2-HR.)  
M.1.1 NOT TO SCALE

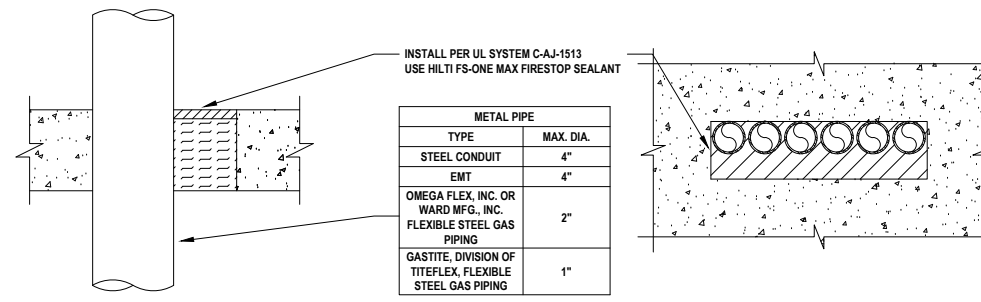

2 MULTIPLE METAL PIPES THROUGH CONCRETE FLOOR (2-HR.)  
M.1.1 NOT TO SCALE

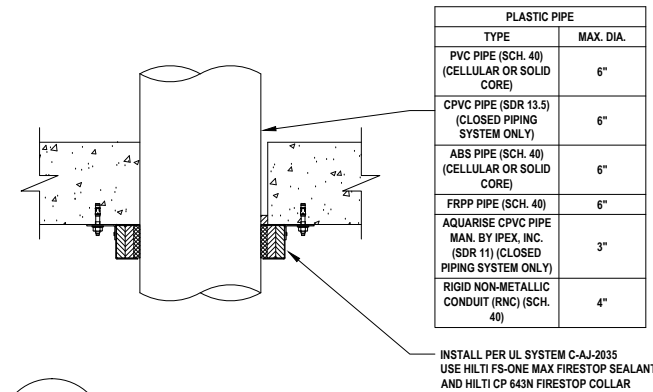

3 PLASTIC PIPE THROUGH CONCRETE FLOOR (2-HR.)  
M.1.1 NOT TO SCALE

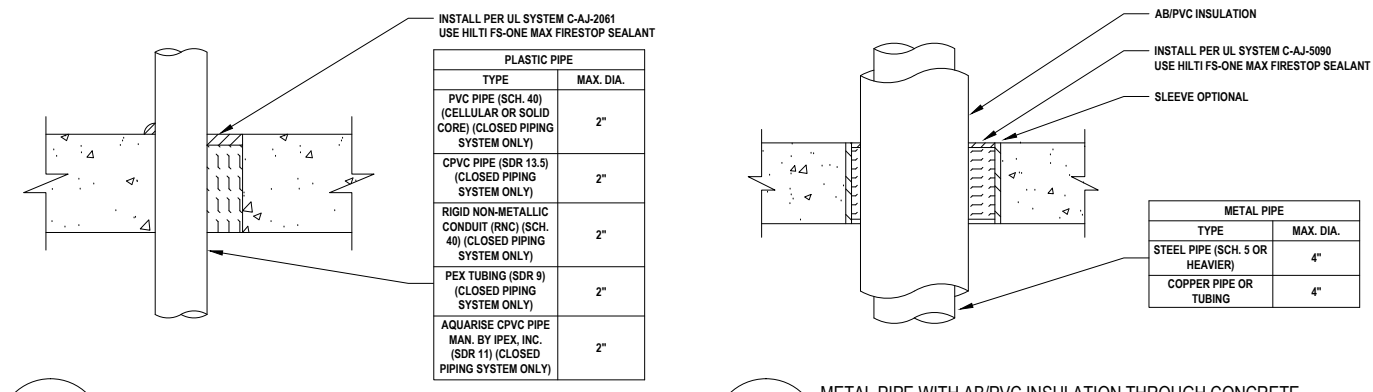

4 PLASTIC PIPE THROUGH CONCRETE FLOOR (2-HR.)  
M.1.1 NOT TO SCALE

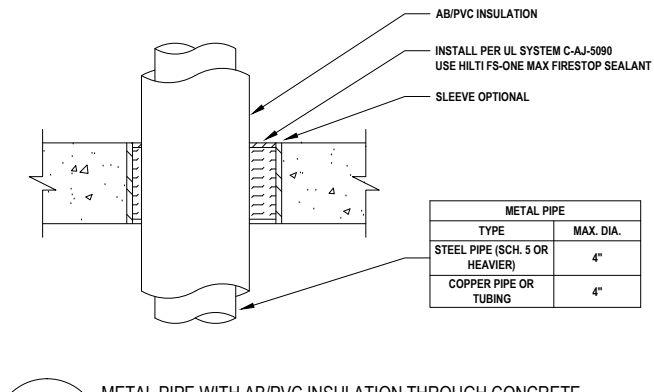

5 METAL PIPE WITH AB/PVC INSULATION THROUGH CONCRETE FLOOR (2-HR.)  
M.1.1 NOT TO SCALE

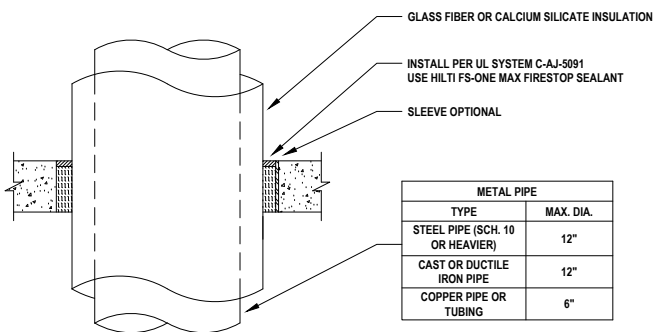

6 METAL PIPE WITH GLASS FIBER OR CALCIUM SILICATE INSULATION THROUGH CONCRETE FLOOR (2-HR.)  
M.1.1 NOT TO SCALE

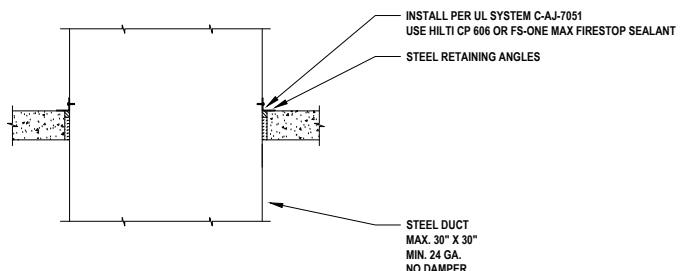

7 METAL DUCT (WITHOUT DAMPER) THROUGH CONCRETE FLOOR (2-HR.)  
M.1.1 NOT TO SCALE

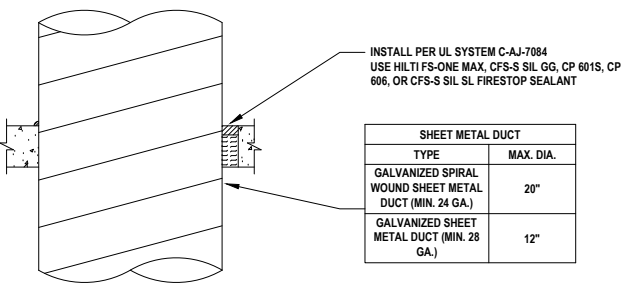

8 ROUND SHEET METAL DUCT THROUGH CONCRETE FLOOR (2-HR.)  
M.1.1 NOT TO SCALE

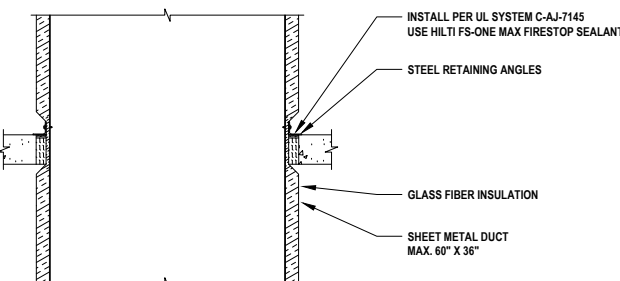

9 SHEET METAL DUCT WITH GLASS FIBER INSULATION THROUGH CONCRETE FLOOR (2-HR.)  
M.1.1 NOT TO SCALE



10 MULTIPLE PENETRATIONS THROUGH CONCRETE FLOOR (2-HR.)  
M.1.1 NOT TO SCALE

Notes:

- Refer to the following specifications for firestopping.
  - 07 84 00 Firestopping
  - 07 84 13 Penetration Firestopping
  - 22 00 00 Plumbing
  - 23 00 00 HVAC
  - 26 00 00 Electrical
  - 27 06 37 Communication

For Quality Control requirements, refer to the Quality Control portion of the specification.

- Details shown are typical details, containing general information only. Always refer to the full UL system detail for complete system requirements. If field conditions do not match requirements of details, approved alternate details shall be utilized. Design requirements, field conditions and dimensions need to be verified for compliance with the details, including but not limited to the following:
  - \* Fire Rating (F-Rating)
  - \* Temperature Rating (T-Rating)
  - \* Leakage Rating (L-Rating)
  - \* Water Rating (W-Rating)
  - \* Annular Space
  - \* Percent Fill
  - \* Movement
  - \* Type and thickness of fire-rated construction.

- If alternate details matching the field conditions are not available, manufacturer's engineering judgment drawings are acceptable. Contact Hilti Inc. for alternative systems or Engineering Judgment (800-879-8000) Drawings shall follow the International Firestop Council (IFC) Guidelines for Evaluating Firestop Systems Engineering Judgments.

References:

- \* 2013 Underwriter's Laboratories Fire Resistance Directory, Volumes 1 & 2
  - \* NFPA 101 Life Safety Code
  - \* NFPA 70 - National Electric Code
  - \* All governing local and regional building codes
- Firestop System installation must meet requirements of ASTM E-814 (UL 1479) tested assemblies that provide a fire rating equal to that of construction being penetrated.
  - All rated through-penetration assemblies shall be prominently labeled with a Hilti Firestop Label equipped with a QR code with the following information:
    - \*Warning! - Do Not Disturb
    - \*Through Penetration Firestop System
    - \* UL System # \* Product(s) used
    - \* Hourly Rating (F-Rating)
    - \* Installation Date
    - \* Contractor's Name
  - For outlet boxes requiring protection, use only Wall Opening Protective Materials, category CLIV as classified by Underwriter's Laboratories, Fire Resistance Directory (Volume 1.)

<Notes to designer (delete this note after reading and replace with title block information)>  
 1. Any modification to these details could result in an application/system not meeting the UL or Intertek Classification or the intended temperature or fire ratings.  
 2. Details shown are up to date as of February 2015.  
 3. For additional information on the details, refer to the most current "Underwriter's Laboratories Fire Resistance Directory (volume 2.)"

JOB NUMBER: \_\_\_\_\_

DRAWN: \_\_\_\_\_

CHECKED: \_\_\_\_\_

ISSUE DATE: \_\_\_\_\_

REVISIONS: \_\_\_\_\_

CONTENTS: \_\_\_\_\_

MECHANICAL PENETRATIONS  
FLAT CONCRETE FLOOR  
2 HR.

SHEET NAME: \_\_\_\_\_

**M.1.1**

SHEET NUMBER: \_\_\_\_\_

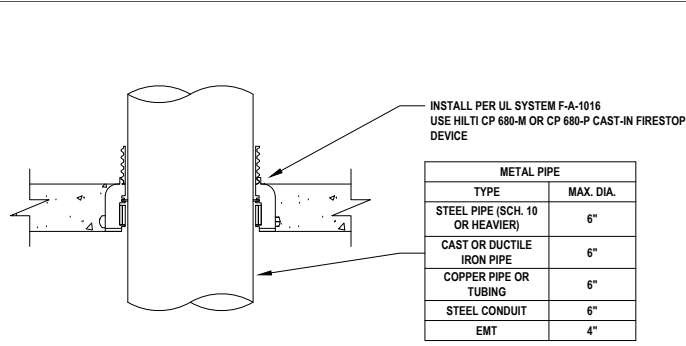

1 METAL PIPE THROUGH CONCRETE FLOOR (2-HR.)  
M.1.2 NOT TO SCALE

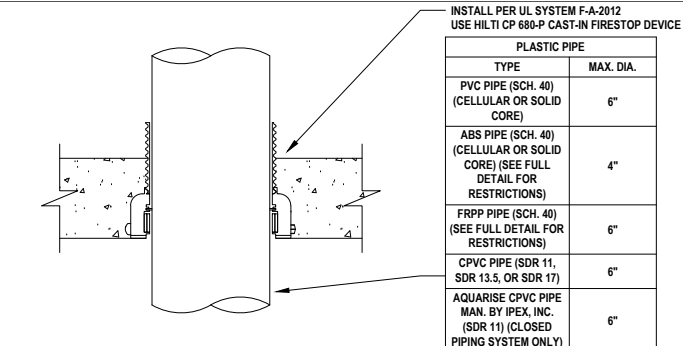

2 PLASTIC PIPE THROUGH CONCRETE FLOOR (2-HR.)  
M.1.2 NOT TO SCALE

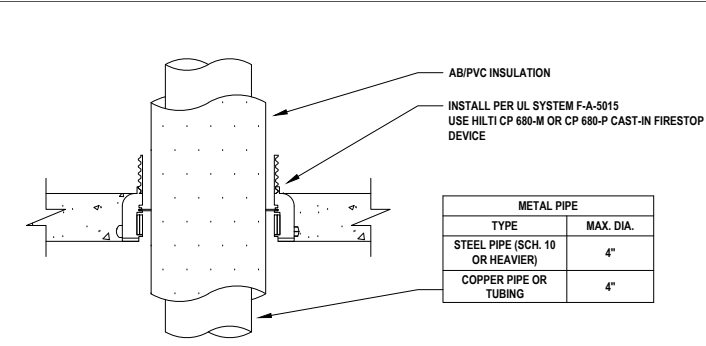

3 METAL PIPE WITH AB/PVC INSULATION THROUGH CONCRETE FLOOR (2-HR.)  
M.1.2 NOT TO SCALE

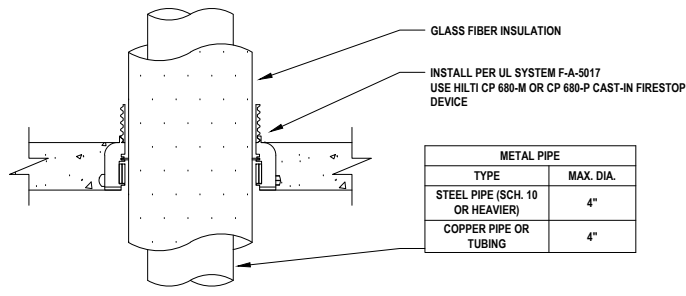

4 METAL PIPE WITH GLASS FIBER INSULATION THROUGH CONCRETE FLOOR (2-HR.)  
M.1.2 NOT TO SCALE

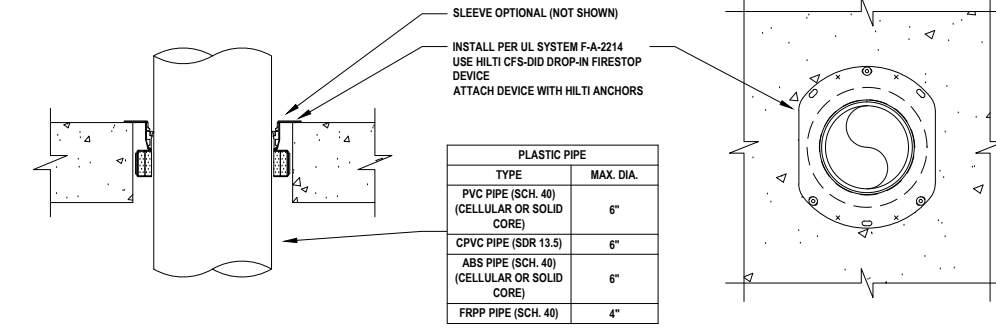

5 PLASTIC PIPE THROUGH CONCRETE FLOOR (2-HR.)  
M.1.2 NOT TO SCALE

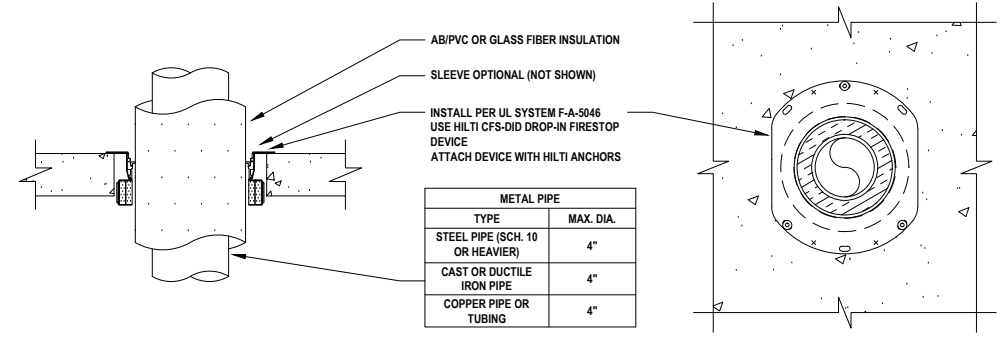

6 METAL PIPE WITH AB/PVC OR GLASS FIBER INSULATION THROUGH CONCRETE FLOOR (2-HR.)  
M.1.2 NOT TO SCALE

Notes:

- Refer to the following specifications for firestopping.
  - 07 84 00 Firestopping
  - 07 84 13 Penetration Firestopping
  - 22 00 00 Plumbing
  - 23 00 00 HVAC
  - 26 00 00 Electrical
  - 27 06 37 Communication

For Quality Control requirements, refer to the Quality Control portion of the specification.

2. Details shown are typical details, containing general information only. Always refer to the full UL system detail for complete system requirements. If field conditions do not match requirements of details, approved alternate details shall be utilized. Design requirements, field conditions and dimensions need to be verified for compliance with the details, including but not limited to the following:

- \* Fire Rating (F-Rating)
- \* Temperature Rating (T-Rating)
- \* Leakage Rating (L-Rating)
- \* Water Rating (W-Rating)
- \* Annular Space
- \* Percent Fill
- \* Movement
- \* Type and thickness of fire-rated construction.

3. If alternate details matching the field conditions are not available, manufacturer's engineering judgment drawings are acceptable. Contact Hilti Inc. for alternative systems or Engineering Judgment (800-879-8000) Drawings shall follow the International Firestop Council (IFC) Guidelines for Evaluating Firestop Systems Engineering Judgments.

4. References:
- \* 2013 Underwriter's Laboratories Fire Resistance Directory, Volumes 1 & 2
  - \* NFPA 101 Life Safety Code
  - \* NFPA 70 - National Electric Code
  - \* All governing local and regional building codes

5. Firestop System installation must meet requirements of ASTM E-814 (UL 1479) tested assemblies that provide a fire rating equal to that of construction being penetrated.

6. All rated through-penetration assemblies shall be prominently labeled with a Hilti Firestop Label equipped with a QR code with the following information:
- \* Warning! - Do Not Disturb
  - \* Through Penetration Firestop System
  - \* UL System # \* Product(s) used
  - \* Hourly Rating (F-Rating)
  - \* Installation Date
  - \* Contractor's Name

7. For outlet boxes requiring protection, use only Wall Opening Protective Materials, category CLIV as classified by Underwriter's Laboratories, Fire Resistance Directory (Volume 1.)

<Notes to designer (delete this note after reading and replace with title block information)>  
 1. Any modification to these details could result in an application/system not meeting the UL or Intertek Classification or the intended temperature or fire ratings.  
 2. Details shown are up to date as of February 2015.  
 3. For additional information on the details, refer to the most current "Underwriter's Laboratories Fire Resistance Directory (volume 2)."

JOB NUMBER: \_\_\_\_\_

DRAWN: \_\_\_\_\_

CHECKED: \_\_\_\_\_

ISSUE DATE: \_\_\_\_\_

REVISIONS: \_\_\_\_\_

CONTENTS: \_\_\_\_\_

MECHANICAL PENETRATIONS  
FLAT CONCRETE FLOOR  
2 HR.

SHEET NAME: \_\_\_\_\_

**M.1.2**

SHEET NUMBER: \_\_\_\_\_

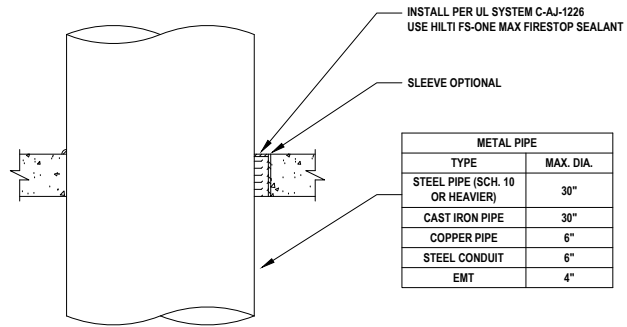

METAL PIPE	
TYPE	MAX. DIA.
STEEL PIPE (SCH. 10 OR HEAVIER)	30"
CAST IRON PIPE	30"
COPPER PIPE	6"
STEEL CONDUIT	6"
EMT	4"

1 METAL PIPE THROUGH CONCRETE FLOOR (3-HR.)  
M.1.3 NOT TO SCALE

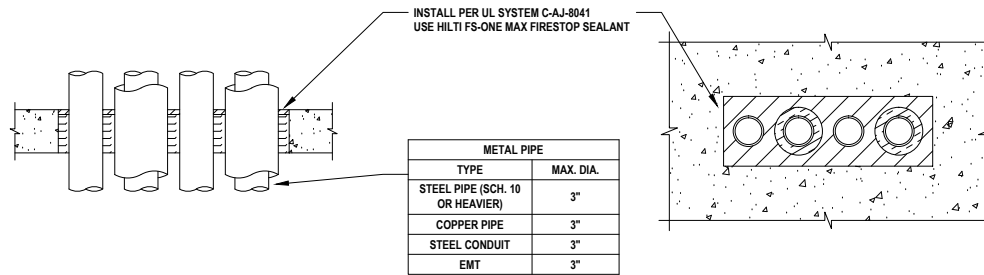

METAL PIPE	
TYPE	MAX. DIA.
STEEL PIPE (SCH. 10 OR HEAVIER)	3"
COPPER PIPE	3"
STEEL CONDUIT	3"
EMT	3"

2 MULTIPLE METAL PIPES THROUGH CONCRETE FLOOR (3-HR.)  
M.1.3 NOT TO SCALE

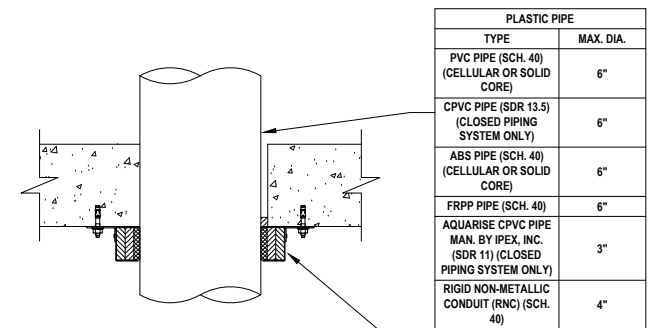

PLASTIC PIPE	
TYPE	MAX. DIA.
PVC PIPE (SCH. 40) (CELLULAR OR SOLID CORE)	6"
CPVC PIPE (SDR 13.5) (CLOSED PIPING SYSTEM ONLY)	6"
ABS PIPE (SCH. 40) (CELLULAR OR SOLID CORE)	6"
FRPP PIPE (SCH. 40)	6"
AQUARISE CPVC PIPE MAN. BY IPEX, INC. (SDR 11) (CLOSED PIPING SYSTEM ONLY)	3"
RIGID NON-METALLIC CONDUIT (RNC) (SCH. 40)	4"

3 PLASTIC PIPE THROUGH CONCRETE FLOOR (3-HR.)  
M.1.3 NOT TO SCALE

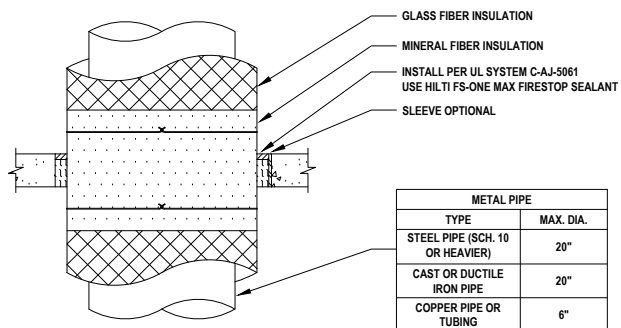

METAL PIPE	
TYPE	MAX. DIA.
STEEL PIPE (SCH. 10 OR HEAVIER)	20"
CAST OR DUCTILE IRON PIPE	20"
COPPER PIPE OR TUBING	6"

4 METAL PIPE WITH GLASS FIBER INSULATION THROUGH CONCRETE FLOOR (3-HR.)  
M.1.3 NOT TO SCALE

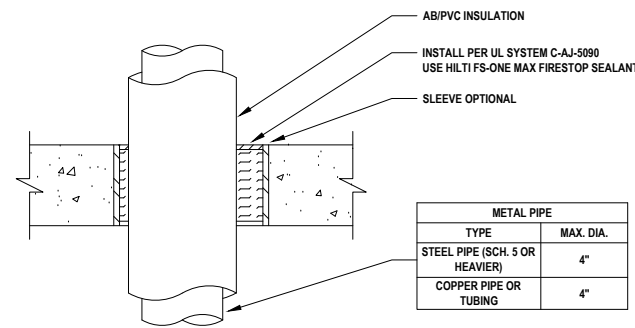

METAL PIPE	
TYPE	MAX. DIA.
STEEL PIPE (SCH. 5 OR HEAVIER)	4"
COPPER PIPE OR TUBING	4"

5 METAL PIPE WITH AB/PVC INSULATION THROUGH CONCRETE FLOOR (3-HR.)  
M.1.3 NOT TO SCALE

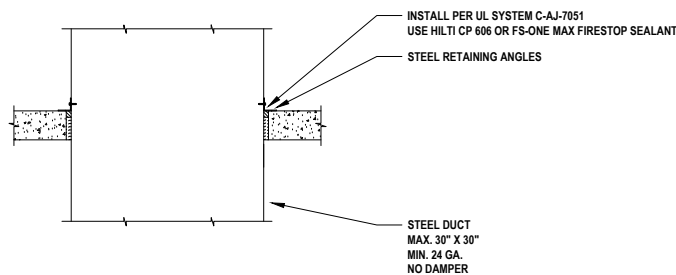

6 METAL DUCT (WITHOUT DAMPER) THROUGH CONCRETE FLOOR (3-HR.)  
M.1.3 NOT TO SCALE

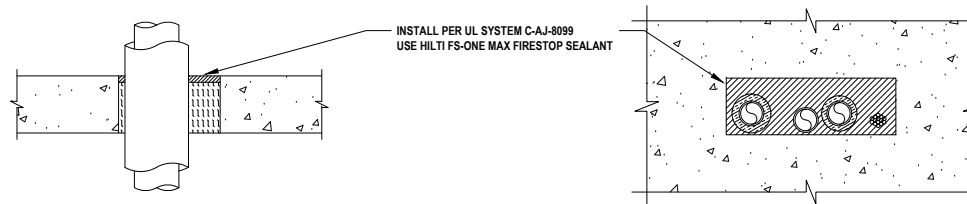

7 MULTIPLE PENETRATIONS THROUGH CONCRETE FLOOR (3-HR.)  
M.1.3 NOT TO SCALE

Notes:

- Refer to the following specifications for firestopping.
  - 07 84 00 Firestopping
  - 07 84 13 Penetration Firestopping
  - 22 00 00 Plumbing
  - 23 00 00 HVAC
  - 26 00 00 Electrical
  - 27 06 37 Communication

For Quality Control requirements, refer to the Quality Control portion of the specification.

- Details shown are typical details, containing general information only. Always refer to the full UL system detail for complete system requirements. If field conditions do not match requirements of details, approved alternate details shall be utilized. Design requirements, field conditions and dimensions need to be verified for compliance with the details, including but not limited to the following:
  - \* Fire Rating (F-Rating)
  - \* Temperature Rating (T-Rating)
  - \* Leakage Rating (L-Rating)
  - \* Water Rating (W-Rating)
  - \* Annular Space
  - \* Percent Fill
  - \* Movement
  - \* Type and thickness of fire-rated construction.

- If alternate details matching the field conditions are not available, manufacturer's engineering judgment drawings are acceptable. Contact Hilti Inc. for alternative systems or Engineering Judgment (800-879-8000) Drawings shall follow the International Firestop Council (IFC) Guidelines for Evaluating Firestop Systems Engineering Judgments.

4. References:

- \* 2013 Underwriter's Laboratories Fire Resistance Directory, Volumes 1 & 2
- \* NFPA 101 Life Safety Code
- \* NFPA 70 - National Electric Code
- \* All governing local and regional building codes

- Firestop System installation must meet requirements of ASTM E-814 (UL 1479) tested assemblies that provide a fire rating equal to that of construction being penetrated.

- All rated through-penetration assemblies shall be prominently labeled with a Hilti Firestop Label equipped with a QR code with the following information:

- \* Warning! - Do Not Disturb
- \* Through Penetration Firestop System
- \* UL System # \* Product(s) used
- \* Hourly Rating (F-Rating)
- \* Installation Date
- \* Contractor's Name

- For outlet boxes requiring protection, use only Wall Opening Protective Materials, category CLIV as classified by Underwriter's Laboratories, Fire Resistance Directory (Volume 1.)

<Notes to designer (delete this note after reading and replace with title block information)>  
 1. Any modification to these details could result in an application/system not meeting the UL or Intertek Classification or the intended temperature or fire ratings.  
 2. Details shown are up to date as of February 2015.  
 3. For additional information on the details, refer to the most current "Underwriter's Laboratories Fire Resistance Directory (volume 2)."

JOB NUMBER: \_\_\_\_\_

DRAWN: \_\_\_\_\_

CHECKED: \_\_\_\_\_

ISSUE DATE: \_\_\_\_\_

REVISIONS: \_\_\_\_\_

CONTENTS: \_\_\_\_\_

MECHANICAL PENETRATIONS  
FLAT CONCRETE FLOOR  
3 HR.

SHEET NAME: \_\_\_\_\_

**M.1.3**

SHEET NUMBER: \_\_\_\_\_

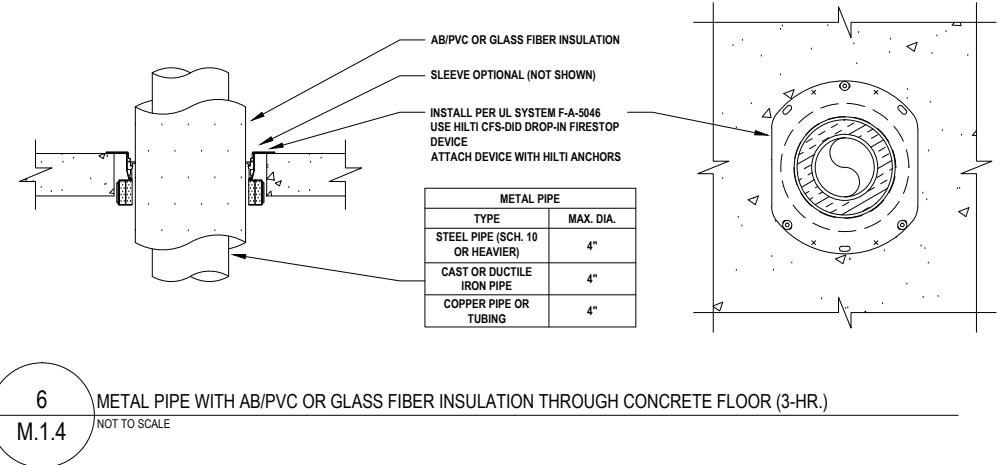
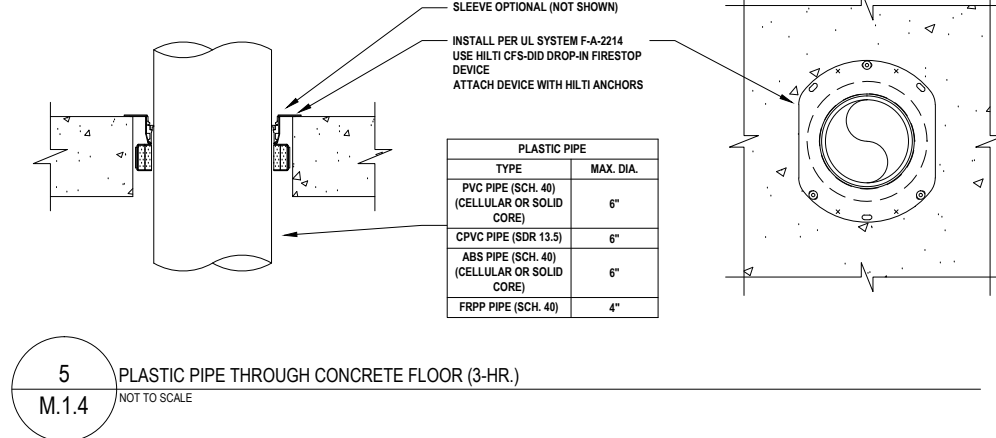
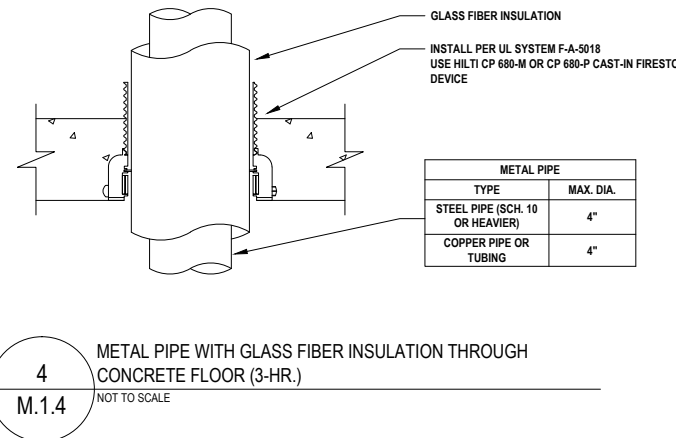
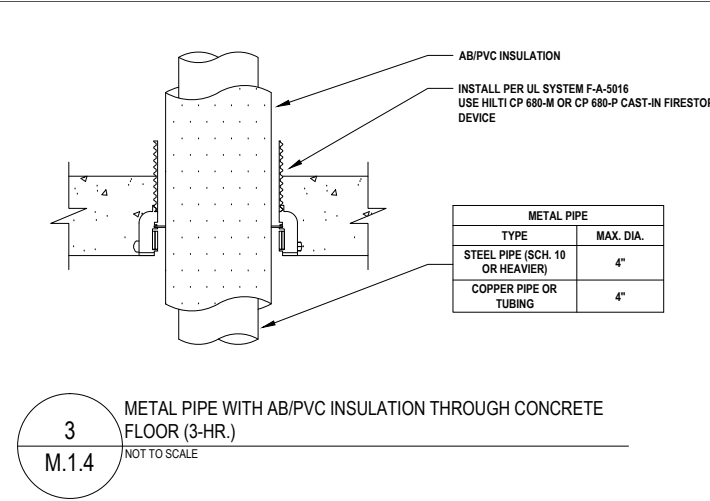
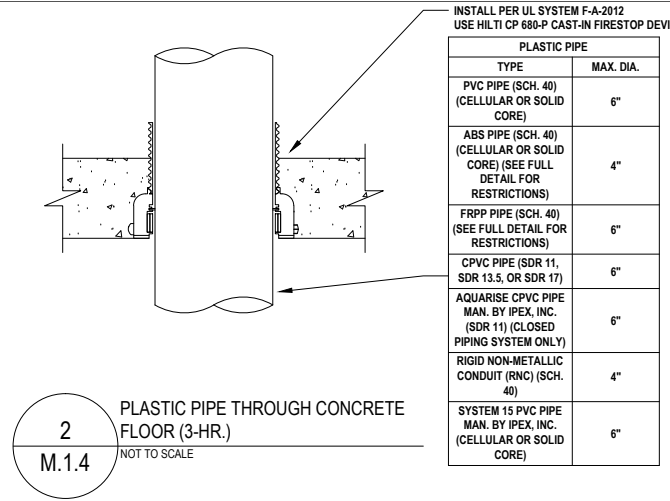
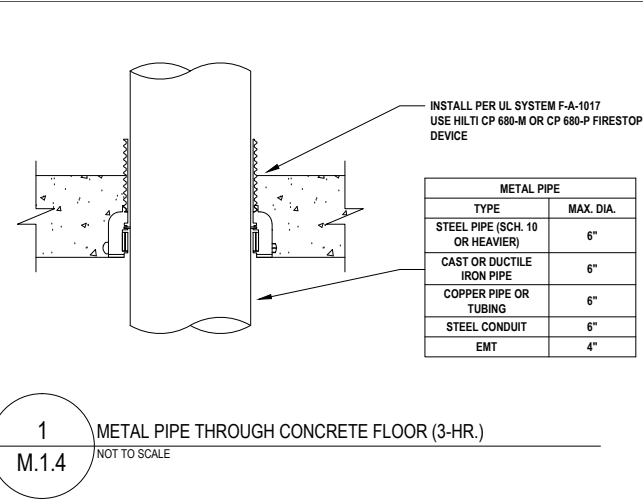

Notes:

- Refer to the following specifications for firestopping.
  - 07 84 00 Firestopping
  - 07 84 13 Penetration Firestopping
  - 22 00 00 Plumbing
  - 23 00 00 HVAC
  - 26 00 00 Electrical
  - 27 06 37 Communication

For Quality Control requirements, refer to the Quality Control portion of the specification.
- Details shown are typical details, containing general information only. Always refer to the full UL system detail for complete system requirements. If field conditions do not match requirements of details, approved alternate details shall be utilized. Design requirements, field conditions and dimensions need to be verified for compliance with the details, including but not limited to the following:
  - \* Fire Rating (F-Rating)
  - \* Temperature Rating (T-Rating)
  - \* Leakage Rating (L-Rating)
  - \* Water Rating (W-Rating)
  - \* Annular Space
  - \* Percent Fill
  - \* Movement
  - \* Type and thickness of fire-rated construction.
- If alternate details matching the field conditions are not available, manufacturer's engineering judgment drawings are acceptable. Contact Hilti Inc. for alternative systems or Engineering Judgment (800-879-8000) Drawings shall follow the International Firestop Council (IFC) Guidelines for Evaluating Firestop Systems Engineering Judgments.
- References:
  - \* 2013 Underwriter's Laboratories Fire Resistance Directory, Volumes 1 & 2
  - \* NFPA 101 Life Safety Code
  - \* NFPA 70 - National Electric Code
  - \* All governing local and regional building codes
- Firestop System installation must meet requirements of ASTM E-814 (UL 1479) tested assemblies that provide a fire rating equal to that of construction being penetrated.
- All rated through-penetration assemblies shall be prominently labeled with a Hilti Firestop Label equipped with a QR code with the following information:
  - \*Warning! - Do Not Disturb
  - \*Through Penetration Firestop System
  - \* UL System # \* Product(s) used
  - \* Hourly Rating (F-Rating)
  - \* Installation Date
  - \* Contractor's Name
- For outlet boxes requiring protection, use only Wall Opening Protective Materials, category CLIV as classified by Underwriter's Laboratories, Fire Resistance Directory (Volume 1.)

<Notes to designer (delete this note after reading and replace with title block information)>  
 1. Any modification to these details could result in an application/system not meeting the UL or Intertek Classification or the intended temperature or fire ratings.  
 2. Details shown are up to date as of February 2015.  
 3. For additional information on the details, refer to the most current "Underwriter's Laboratories Fire Resistance Directory (volume 2)."

JOB NUMBER: \_\_\_\_\_

DRAWN: \_\_\_\_\_

CHECKED: \_\_\_\_\_

ISSUE DATE: \_\_\_\_\_

REVISIONS: \_\_\_\_\_

CONTENTS: \_\_\_\_\_

MECHANICAL PENETRATIONS  
FLAT CONCRETE FLOOR  
3 HR.

SHEET NAME: \_\_\_\_\_

**M.1.4**

SHEET NUMBER: \_\_\_\_\_

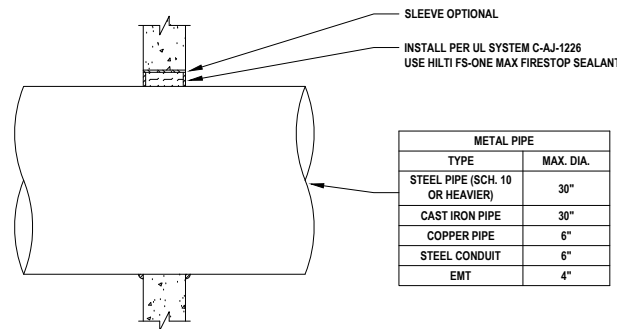

1 METAL PIPE THROUGH CONCRETE WALL (2-HR.)  
M.2.1 NOT TO SCALE

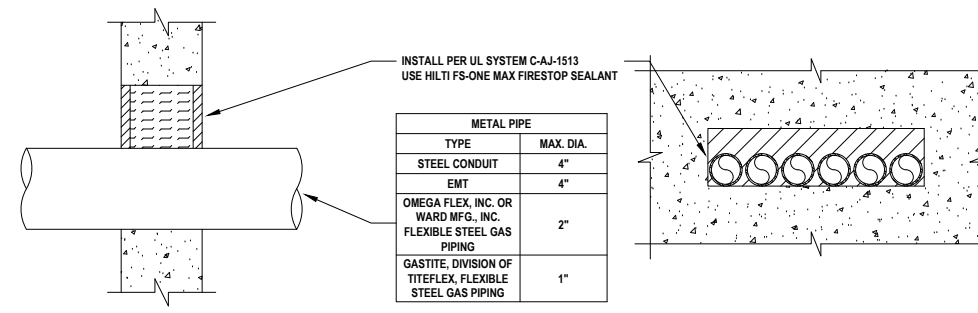

2 MULTIPLE METAL PIPES THROUGH CONCRETE WALL (2-HR.)  
M.2.1 NOT TO SCALE

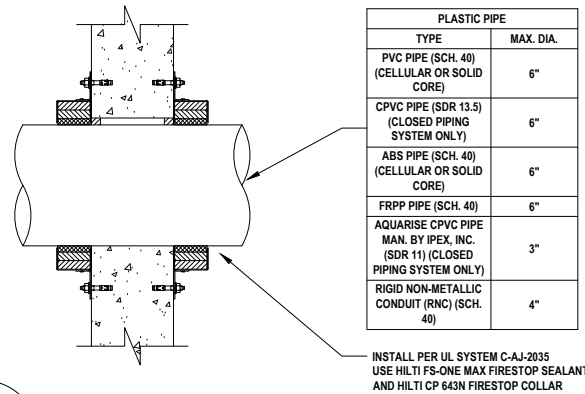

3 PLASTIC PIPE THROUGH CONCRETE WALL (2-HR.)  
M.2.1 NOT TO SCALE

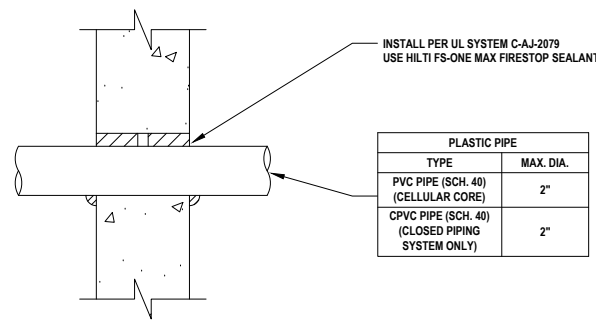

4 PLASTIC PIPE THROUGH CONCRETE WALL (2-HR.)  
M.2.1 NOT TO SCALE

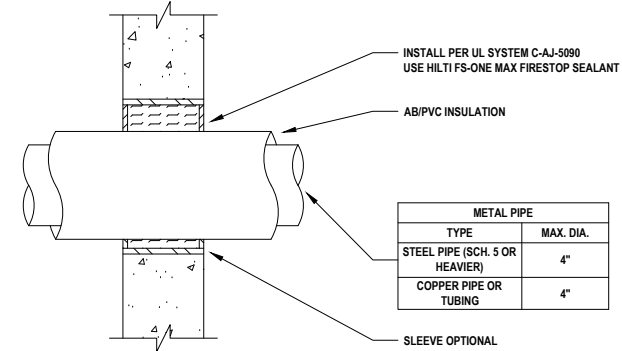

5 METAL PIPE WITH AB/PVC INSULATION THROUGH CONCRETE WALL (2-HR.)  
M.2.1 NOT TO SCALE

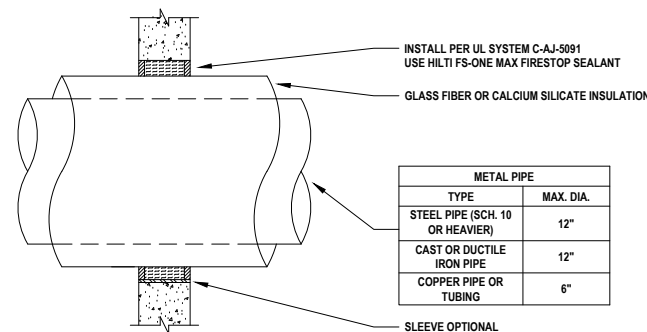

6 METAL PIPE WITH GLASS FIBER OR CALCIUM SILICATE INSULATION THROUGH CONCRETE WALL (2-HR.)  
M.2.1 NOT TO SCALE

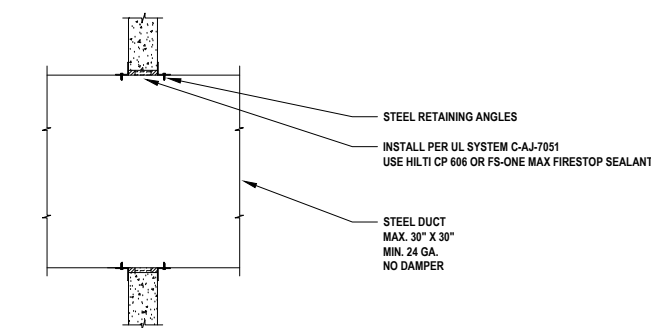

7 METAL DUCT (WITHOUT DAMPER) THROUGH CONCRETE WALL (2-HR.)  
M.2.1 NOT TO SCALE

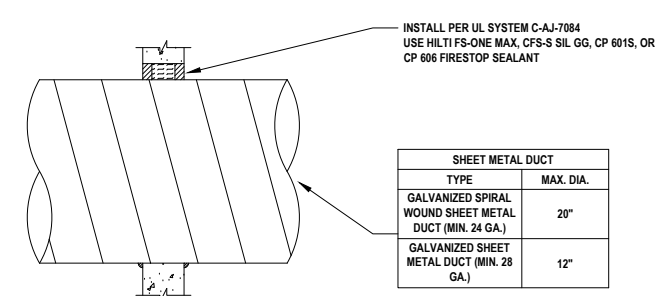

8 ROUND SHEET METAL DUCT THROUGH CONCRETE WALL (2-HR.)  
M.2.1 NOT TO SCALE

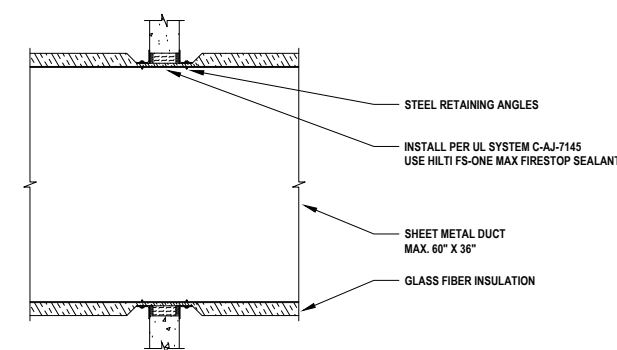

9 SHEET METAL DUCT WITH GLASS FIBER INSULATION THROUGH CONCRETE WALL (2-HR.)  
M.2.1 NOT TO SCALE

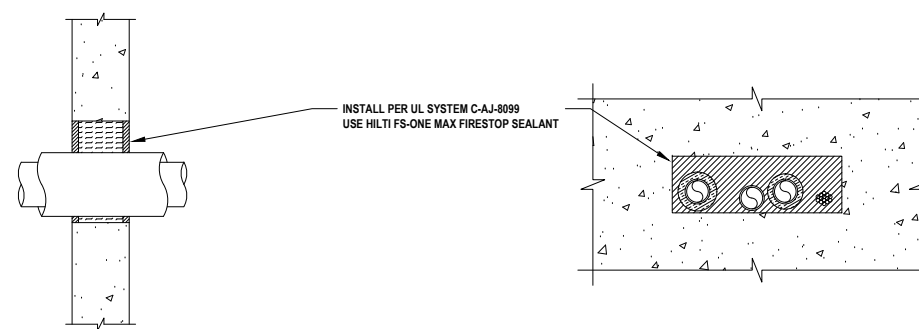

10 MULTIPLE PENETRATIONS THROUGH CONCRETE WALL (2-HR.)  
M.2.1 NOT TO SCALE

Notes:

- Refer to the following specifications for firestopping.
  - 07 84 00 Firestopping
  - 07 84 13 Penetration Firestopping
  - 22 00 00 Plumbing
  - 23 00 00 HVAC
  - 26 00 00 Electrical
  - 27 06 37 Communication

For Quality Control requirements, refer to the Quality Control portion of the specification.

- Details shown are typical details, containing general information only. Always refer to the full UL system detail for complete system requirements. If field conditions do not match requirements of details, approved alternate details shall be utilized. Design requirements, field conditions and dimensions need to be verified for compliance with the details, including but not limited to the following:
  - \* Fire Rating (F-Rating)
  - \* Temperature Rating (T-Rating)
  - \* Leakage Rating (L-Rating)
  - \* Water Rating (W-Rating)
  - \* Annular Space
  - \* Percent Fill
  - \* Movement
  - \* Type and thickness of fire-rated construction.

- If alternate details matching the field conditions are not available, manufacturer's engineering judgment drawings are acceptable. Contact Hilti Inc. for alternative systems or Engineering Judgment (800-879-8000) Drawings shall follow the International Firestop Council (IFC) Guidelines for Evaluating Firestop Systems Engineering Judgments.

References:

- \* 2013 Underwriter's Laboratories Fire Resistance Directory, Volumes 1 & 2
  - \* NFPA 101 Life Safety Code
  - \* NFPA 70 - National Electric Code
  - \* All governing local and regional building codes
- Firestop System installation must meet requirements of ASTM E-814 (UL 1479) tested assemblies that provide a fire rating equal to that of construction being penetrated.
  - All rated through-penetration assemblies shall be prominently labeled with a Hilti Firestop Label equipped with a QR code with the following information:
    - \*Warning! - Do Not Disturb
    - \*Through Penetration Firestop System
    - \* UL System # \* Product(s) used
    - \* Hourly Rating (F-Rating)
    - \* Installation Date
    - \* Contractor's Name
  - For outlet boxes requiring protection, use only Wall Opening Protective Materials, category CLIV as classified by Underwriter's Laboratories, Fire Resistance Directory (Volume 1.)

<Notes to designer (delete this note after reading and replace with title block information)>  
 1. Any modification to these details could result in an application/system not meeting the UL or Intertek Classification or the intended temperature or fire ratings.  
 2. Details shown are up to date as of February 2015.  
 3. For additional information on the details, refer to the most current "Underwriter's Laboratories Fire Resistance Directory (volume 2)."

JOB NUMBER: \_\_\_\_\_

DRAWN: \_\_\_\_\_

CHECKED: \_\_\_\_\_

ISSUE DATE: \_\_\_\_\_

REVISIONS: \_\_\_\_\_

CONTENTS: \_\_\_\_\_

MECHANICAL PENETRATIONS  
CONCRETE/BLOCK WALL  
2 HR.

SHEET NAME: \_\_\_\_\_

**M.2.1**

SHEET NUMBER: \_\_\_\_\_

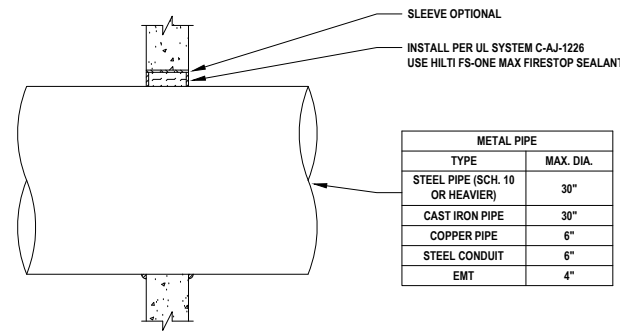

METAL PIPE	
TYPE	MAX. DIA.
STEEL PIPE (SCH. 10 OR HEAVIER)	30"
CAST IRON PIPE	30"
COPPER PIPE	6"
STEEL CONDUIT	6"
EMT	4"

1 METAL PIPE THROUGH CONCRETE WALL (3-HR.)  
M.2.2 NOT TO SCALE

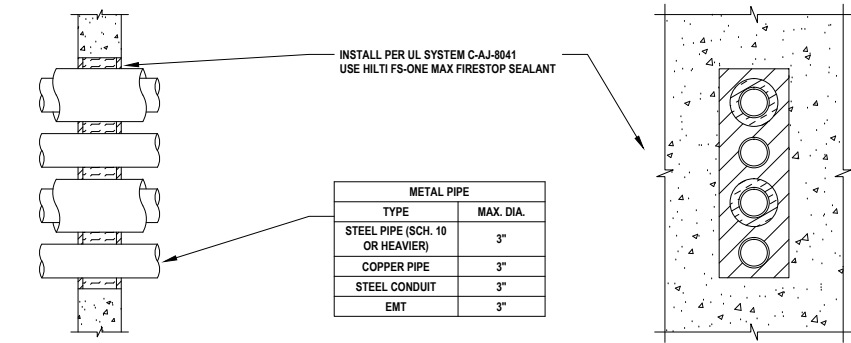

METAL PIPE	
TYPE	MAX. DIA.
STEEL PIPE (SCH. 10 OR HEAVIER)	3"
COPPER PIPE	3"
STEEL CONDUIT	3"
EMT	3"

2 MULTIPLE METAL PIPES THROUGH CONCRETE WALL (3-HR.)  
E.1.3 NOT TO SCALE

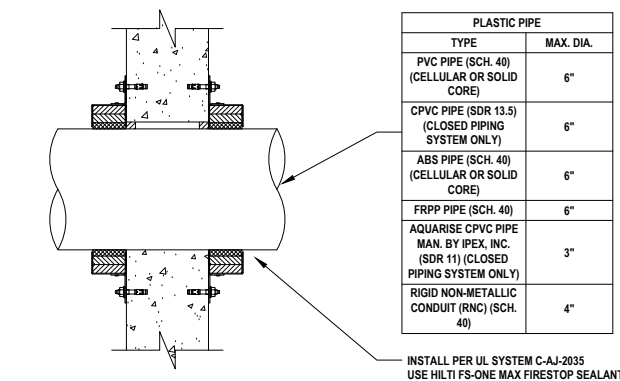

PLASTIC PIPE	
TYPE	MAX. DIA.
PVC PIPE (SCH. 40) (CELLULAR OR SOLID CORE)	6"
CPVC PIPE (SDR 13.5) (CLOSED PIPING SYSTEM ONLY)	6"
ABS PIPE (SCH. 40) (CELLULAR OR SOLID CORE)	6"
FRPP PIPE (SCH. 40)	6"
AQUARISE CPVC PIPE MAN. BY IPEX, INC. (SDR 11) (CLOSED PIPING SYSTEM ONLY)	3"
RIGID NON-METALLIC CONDUIT (RNC) (SCH. 40)	4"

3 PLASTIC PIPE THROUGH CONCRETE WALL (3-HR.)  
M.2.2 NOT TO SCALE

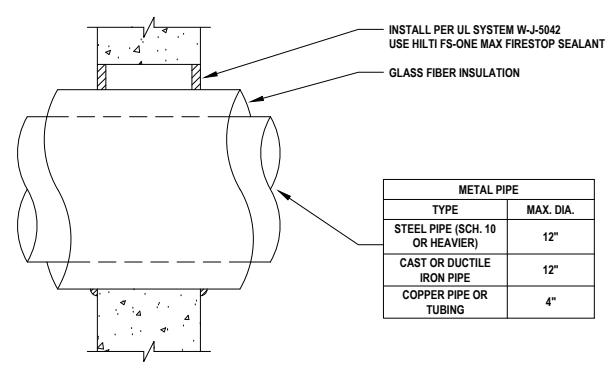

METAL PIPE	
TYPE	MAX. DIA.
STEEL PIPE (SCH. 10 OR HEAVIER)	12"
CAST OR DUCTILE IRON PIPE	12"
COPPER PIPE OR TUBING	4"

4 METAL PIPE WITH GLASS FIBER INSULATION THROUGH CONCRETE WALL (3-HR.)  
M.2.2 NOT TO SCALE

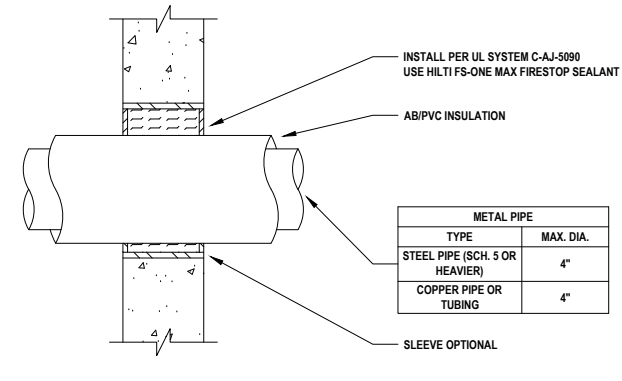

METAL PIPE	
TYPE	MAX. DIA.
STEEL PIPE (SCH. 5 OR HEAVIER)	4"
COPPER PIPE OR TUBING	4"

5 METAL PIPE WITH AB/PVC INSULATION THROUGH CONCRETE WALL (3-HR.)  
M.2.2 NOT TO SCALE

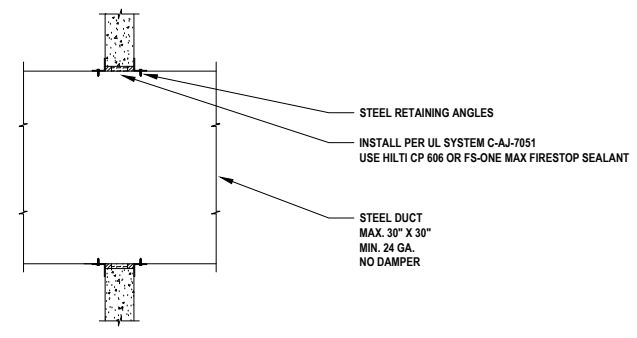

6 METAL DUCT (WITHOUT DAMPER) THROUGH CONCRETE WALL (3-HR.)  
M.2.2 NOT TO SCALE

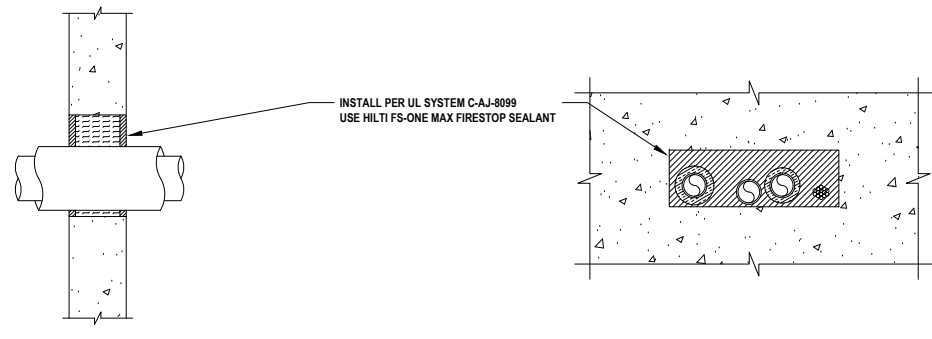

7 MULTIPLE PENETRATIONS THROUGH CONCRETE WALL (3-HR.)  
M.2.2 NOT TO SCALE

Notes:

- Refer to the following specifications for firestopping.
  - 07 84 00 Firestopping
  - 07 84 13 Penetration Firestopping
  - 22 00 00 Plumbing
  - 23 00 00 HVAC
  - 26 00 00 Electrical
  - 27 06 37 Communication

For Quality Control requirements, refer to the Quality Control portion of the specification.

- Details shown are typical details, containing general information only. Always refer to the full UL system detail for complete system requirements. If field conditions do not match requirements of details, approved alternate details shall be utilized. Design requirements, field conditions and dimensions need to be verified for compliance with the details, including but not limited to the following:
  - \* Fire Rating (F-Rating)
  - \* Temperature Rating (T-Rating)
  - \* Leakage Rating (L-Rating)
  - \* Water Rating (W-Rating)
  - \* Annular Space
  - \* Percent Fill
  - \* Movement
  - \* Type and thickness of fire-rated construction.

- If alternate details matching the field conditions are not available, manufacturer's engineering judgment drawings are acceptable. Contact Hilti Inc. for alternative systems or Engineering Judgment (800-879-8000) Drawings shall follow the International Firestop Council (IFC) Guidelines for Evaluating Firestop Systems Engineering Judgments.

4. References:

- \* 2013 Underwriter's Laboratories Fire Resistance Directory, Volumes 1 & 2
- \* NFPA 101 Life Safety Code
- \* NFPA 70 - National Electric Code
- \* All governing local and regional building codes

- Firestop System installation must meet requirements of ASTM E-814 (UL 1479) tested assemblies that provide a fire rating equal to that of construction being penetrated.

- All rated through-penetration assemblies shall be prominently labeled with a Hilti Firestop Label equipped with a QR code with the following information:
  - \*Warning! - Do Not Disturb
  - \*Through Penetration Firestop System
  - \* UL System # \* Product(s) used
  - \* Hourly Rating (F-Rating)
  - \* Installation Date
  - \* Contractor's Name

- For outlet boxes requiring protection, use only Wall Opening Protective Materials, category CLIV as classified by Underwriter's Laboratories, Fire Resistance Directory (Volume 1.)

<Notes to designer (delete this note after reading and replace with title block information)>  
 1. Any modification to these details could result in an application/system not meeting the UL or Intertek Classification or the intended temperature or fire ratings.  
 2. Details shown are up to date as of February 2015.  
 3. For additional information on the details, refer to the most current "Underwriter's Laboratories Fire Resistance Directory (volume 2.)"

JOB NUMBER: \_\_\_\_\_

DRAWN: \_\_\_\_\_

CHECKED: \_\_\_\_\_

ISSUE DATE: \_\_\_\_\_

REVISIONS: \_\_\_\_\_

CONTENTS: \_\_\_\_\_

MECHANICAL PENETRATIONS  
CONCRETE/BLOCK WALL  
3 HR.

SHEET NAME: \_\_\_\_\_

**M.2.2**

SHEET NUMBER: \_\_\_\_\_

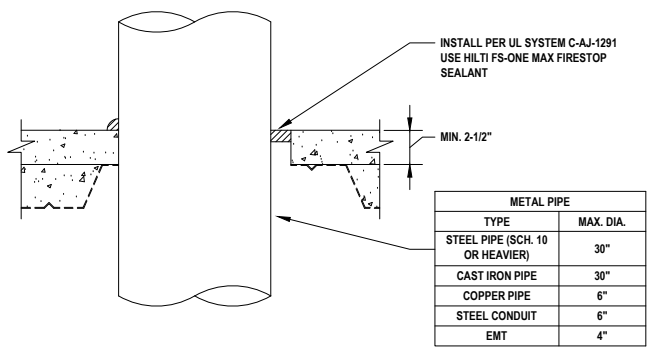

METAL PIPE	
TYPE	MAX. DIA.
STEEL PIPE (SCH. 10 OR HEAVIER)	30"
CAST IRON PIPE	30"
COPPER PIPE	6"
STEEL CONDUIT	6"
EMT	4"

**1** METAL PIPE THROUGH CONCRETE OVER METAL DECKING (2-HR.)  
M.3.1 NOT TO SCALE

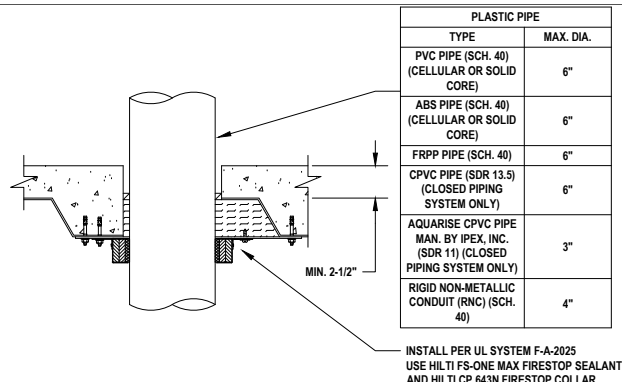

PLASTIC PIPE	
TYPE	MAX. DIA.
PVC PIPE (SCH. 40) (CELLULAR OR SOLID CORE)	6"
ABS PIPE (SCH. 40) (CELLULAR OR SOLID CORE)	6"
FRPP PIPE (SCH. 40)	6"
CPVC PIPE (SDR 13.5) (CLOSED PIPING SYSTEM ONLY)	6"
AQUARISE CPVC PIPE MAN. BY IPEX, INC. (SDR 11) (CLOSED PIPING SYSTEM ONLY)	3"
RIGID NON-METALLIC CONDUIT (RNC) (SCH. 40)	4"

**2** PLASTIC PIPE THROUGH CONCRETE OVER METAL DECKING (2-HR.)  
M.3.1 NOT TO SCALE

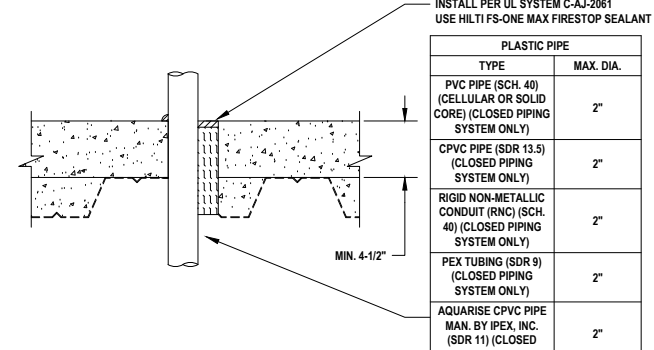

PLASTIC PIPE	
TYPE	MAX. DIA.
PVC PIPE (SCH. 40) (CELLULAR OR SOLID CORE) (CLOSED PIPING SYSTEM ONLY)	2"
CPVC PIPE (SDR 13.5) (CLOSED PIPING SYSTEM ONLY)	2"
RIGID NON-METALLIC CONDUIT (RNC) (SCH. 40) (CLOSED PIPING SYSTEM ONLY)	2"
PEX TUBING (SDR 9) (CLOSED PIPING SYSTEM ONLY)	2"
AQUARISE CPVC PIPE MAN. BY IPEX, INC. (SDR 11) (CLOSED PIPING SYSTEM ONLY)	2"

**3** PLASTIC PIPE THROUGH CONCRETE OVER METAL DECKING (2-HR.)  
M.3.1 NOT TO SCALE

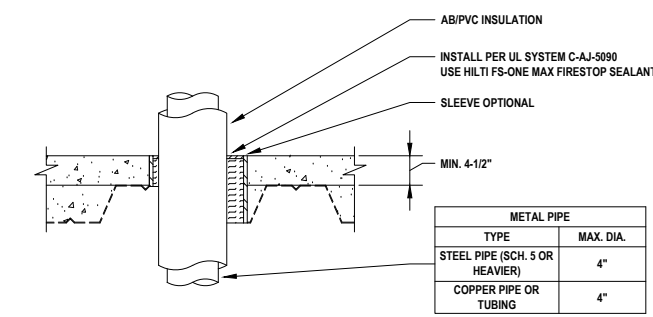

METAL PIPE	
TYPE	MAX. DIA.
STEEL PIPE (SCH. 5 OR HEAVIER)	4"
COPPER PIPE OR TUBING	4"

**4** METAL PIPE WITH AB/PVC INSULATION THROUGH CONCRETE OVER METAL DECKING (2-HR.)  
M.3.1 NOT TO SCALE

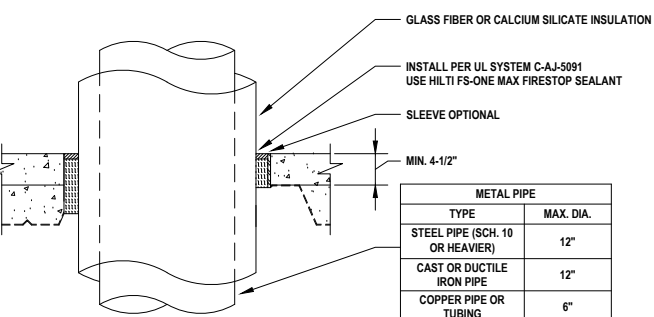

METAL PIPE	
TYPE	MAX. DIA.
STEEL PIPE (SCH. 10 OR HEAVIER)	12"
CAST OR DUCTILE IRON PIPE	12"
COPPER PIPE OR TUBING	6"

**5** METAL PIPE WITH GLASS FIBER OR CALCIUM SILICATE INSULATION THROUGH CONCRETE OVER METAL DECKING (2-HR.)  
M.3.1 NOT TO SCALE

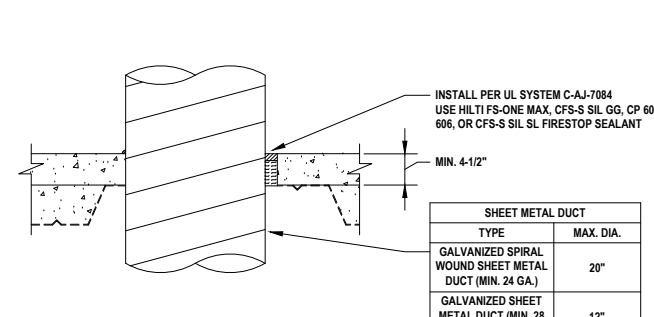

SHEET METAL DUCT	
TYPE	MAX. DIA.
GALVANIZED SPIRAL WOUND SHEET METAL DUCT (MIN. 24 GA.)	20"
GALVANIZED SHEET METAL DUCT (MIN. 28 GA.)	12"

**6** ROUND SHEET METAL DUCT THROUGH CONCRETE OVER METAL DECKING (2-HR.)  
M.3.1 NOT TO SCALE

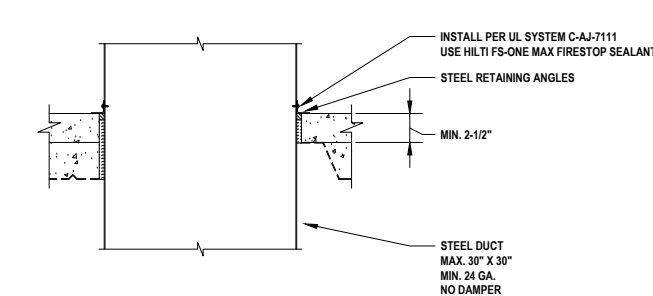

STEEL DUCT MAX. 30" X 30" MIN. 24 GA. NO DAMPER

**7** METAL DUCT (WITHOUT DAMPER) THROUGH CONCRETE OVER METAL DECKING (2-HR.)  
M.3.1 NOT TO SCALE

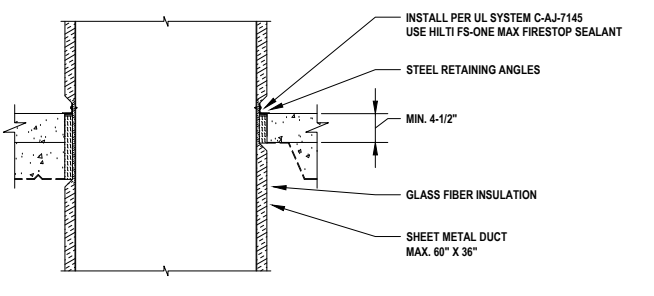

SHEET METAL DUCT MAX. 60" X 36"

**8** SHEET METAL DUCT WITH GLASS FIBER INSULATION THROUGH CONCRETE OVER METAL DECKING (2-HR.)  
M.3.1 NOT TO SCALE

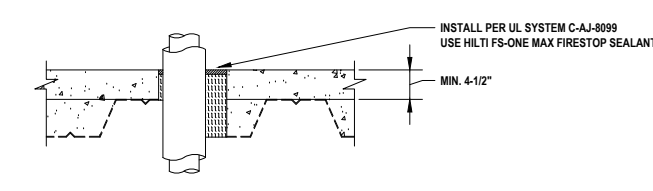

INSTALL PER UL SYSTEM C-AJ-8099 USE HILTI FS-ONE MAX FIRESTOP SEALANT

**9** MULTIPLE PENETRATIONS THROUGH CONCRETE OVER METAL DECKING (2-HR.)  
M.3.1 NOT TO SCALE

**Notes:**

- Refer to the following specifications for firestopping.
  - 07 84 00 Firestopping
  - 07 84 13 Penetration Firestopping
  - 22 00 00 Plumbing
  - 23 00 00 HVAC
  - 26 00 00 Electrical
  - 27 06 37 Communication
- For Quality Control requirements, refer to the Quality Control portion of the specification.
- Details shown are typical details, containing general information only. Always refer to the full UL system detail for complete system requirements. If field conditions do not match requirements of details, approved alternate details shall be utilized. Design requirements, field conditions and dimensions need to be verified for compliance with the details, including but not limited to the following:
  - \* Fire Rating (F-Rating)
  - \* Temperature Rating (T-Rating)
  - \* Leakage Rating (L-Rating)
  - \* Water Rating (W-Rating)
  - \* Annular Space
  - \* Percent Fill
  - \* Movement
  - \* Type and thickness of fire-rated construction.
- If alternate details matching the field conditions are not available, manufacturer's engineering judgment drawings are acceptable. Contact Hilti Inc. for alternative systems or Engineering Judgment (800-879-8000) Drawings shall follow the International Firestop Council (IFC) Guidelines for Evaluating Firestop Systems Engineering Judgments.
- References:
  - \* 2013 Underwriter's Laboratories Fire Resistance Directory, Volumes 1 & 2
  - \* NFPA 101 Life Safety Code
  - \* NFPA 70 - National Electric Code
  - \* All governing local and regional building codes
- Firestop System installation must meet requirements of ASTM E-814 (UL 1479) tested assemblies that provide a fire rating equal to that of construction being penetrated.
- All rated through-penetration assemblies shall be prominently labeled with a Hilti Firestop Label equipped with a QR code with the following information:
  - \* Warning! - Do Not Disturb
  - \* Through Penetration Firestop System
  - \* UL System # \* Product(s) used
  - \* Hourly Rating (F-Rating)
  - \* Installation Date
  - \* Contractor's Name
- For outlet boxes requiring protection, use only Wall Opening Protective Materials, category CLIV as classified by Underwriter's Laboratories, Fire Resistance Directory (Volume 1.)

<Notes to designer (delete this note after reading and replace with title block information)>  
 1. Any modification to these details could result in an application/system not meeting the UL or Intertek Classification or the intended temperature or fire ratings.  
 2. Details shown are up to date as of February 2015.  
 3. For additional information on the details, refer to the most current "Underwriter's Laboratories Fire Resistance Directory (volume 2.)"

JOB NUMBER: \_\_\_\_\_

DRAWN: \_\_\_\_\_

CHECKED: \_\_\_\_\_

ISSUE DATE: \_\_\_\_\_

REVISIONS: \_\_\_\_\_

CONTENTS: \_\_\_\_\_

MECHANICAL PENETRATIONS CONCRETE OVER METAL DECK 2 HR.

SHEET NAME: \_\_\_\_\_

**M.3.1**

SHEET NUMBER: \_\_\_\_\_

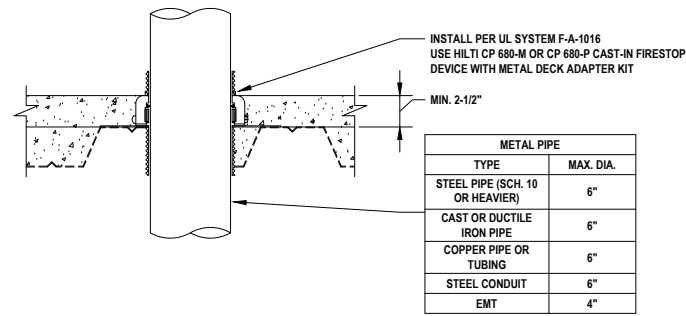

**1**  
M.3.2  
METAL PIPE THROUGH CONCRETE OVER METAL DECKING (2-HR.)  
NOT TO SCALE

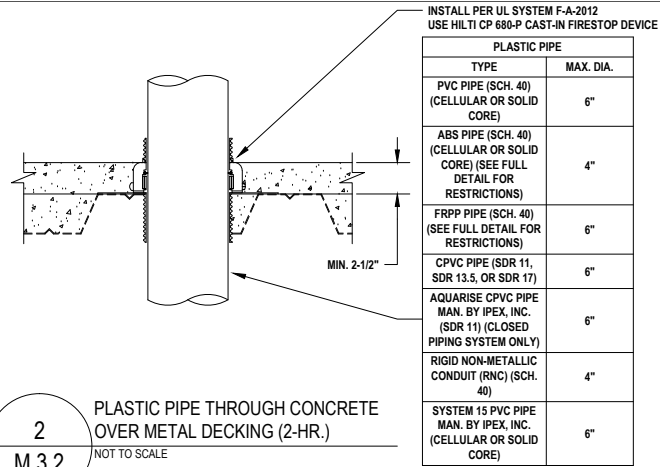

**2**  
M.3.2  
PLASTIC PIPE THROUGH CONCRETE OVER METAL DECKING (2-HR.)  
NOT TO SCALE

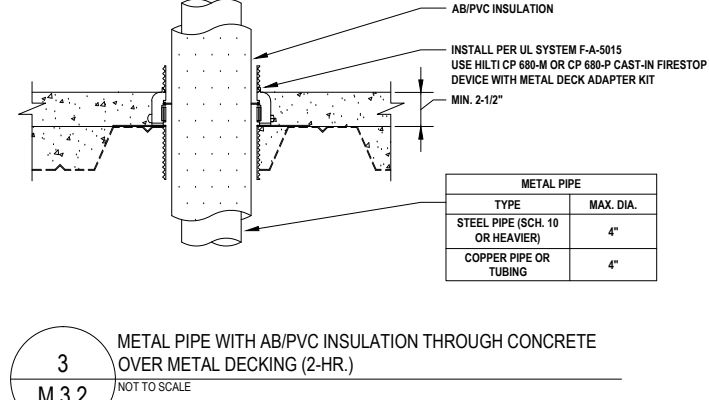

**3**  
M.3.2  
METAL PIPE WITH AB/PVC INSULATION THROUGH CONCRETE OVER METAL DECKING (2-HR.)  
NOT TO SCALE

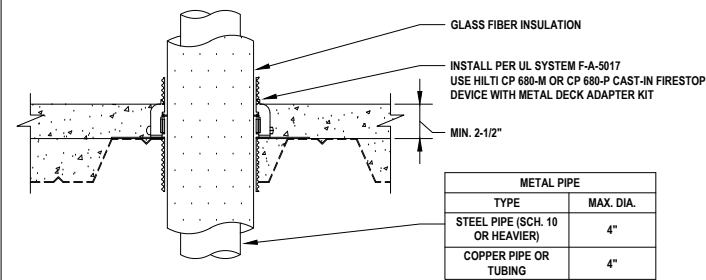

**4**  
M.3.2  
METAL PIPE WITH GLASS FIBER INSULATION THROUGH CONCRETE OVER METAL DECKING (2-HR.)  
NOT TO SCALE

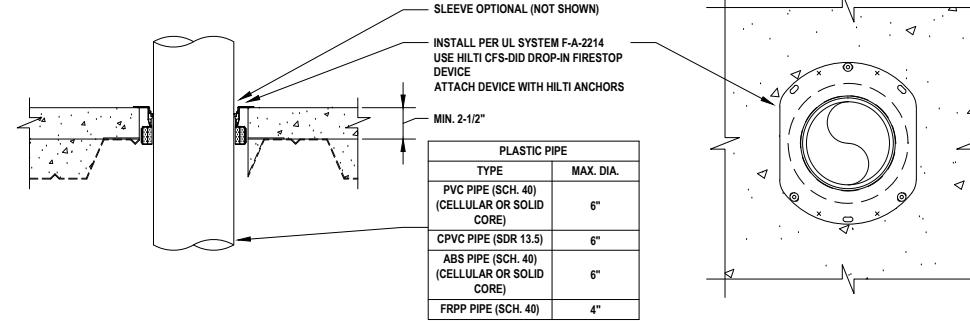

**5**  
M.3.2  
PLASTIC PIPE THROUGH CONCRETE OVER METAL DECKING (2-HR.)  
NOT TO SCALE

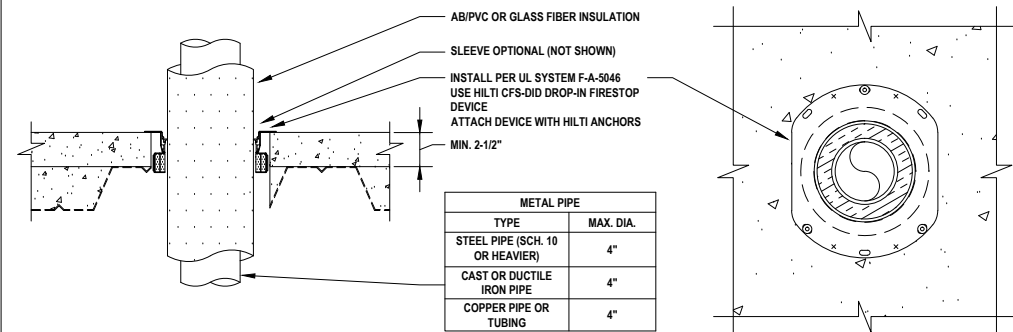

**6**  
M.3.2  
METAL PIPE WITH AB/PVC OR GLASS FIBER INSULATION THROUGH CONCRETE OVER METAL DECKING (2-HR.)  
NOT TO SCALE

Notes:

- Refer to the following specifications for firestopping.
  - 07 84 00 Firestopping
  - 07 84 13 Penetration Firestopping
  - 22 00 00 Plumbing
  - 23 00 00 HVAC
  - 26 00 00 Electrical
  - 27 06 37 Communication

For Quality Control requirements, refer to the Quality Control portion of the specification.

- Details shown are typical details, containing general information only. Always refer to the full UL system detail for complete system requirements. If field conditions do not match requirements of details, approved alternate details shall be utilized. Design requirements, field conditions and dimensions need to be verified for compliance with the details, including but not limited to the following:
  - \* Fire Rating (F-Rating)
  - \* Temperature Rating (T-Rating)
  - \* Leakage Rating (L-Rating)
  - \* Water Rating (W-Rating)
  - \* Annular Space
  - \* Percent Fill
  - \* Movement
  - \* Type and thickness of fire-rated construction.

- If alternate details matching the field conditions are not available, manufacturer's engineering judgment drawings are acceptable. Contact Hilti Inc. for alternative systems or Engineering Judgment (800-879-8000) Drawings shall follow the International Firestop Council (IFC) Guidelines for Evaluating Firestop Systems Engineering Judgments.

References:

- \* 2013 Underwriter's Laboratories Fire Resistance Directory, Volumes 1 & 2
  - \* NFPA 101 Life Safety Code
  - \* NFPA 70 - National Electric Code
  - \* All governing local and regional building codes
- Firestop System installation must meet requirements of ASTM E-814 (UL 1479) tested assemblies that provide a fire rating equal to that of construction being penetrated.
  - All rated through-penetration assemblies shall be prominently labeled with a Hilti Firestop Label equipped with a QR code with the following information:
    - \* Warning! - Do Not Disturb
    - \* Through Penetration Firestop System
    - \* UL System # \* Product(s) used
    - \* Hourly Rating (F-Rating)
    - \* Installation Date
    - \* Contractor's Name
  - For outlet boxes requiring protection, use only Wall Opening Protective Materials, category CLIV as classified by Underwriter's Laboratories, Fire Resistance Directory (Volume 1.)

<Notes to designer (delete this note after reading and replace with title block information)>  
 1. Any modification to these details could result in an application/system not meeting the UL or Intertek Classification or the intended temperature or fire ratings.  
 2. Details shown are up to date as of February 2015.  
 3. For additional information on the details, refer to the most current "Underwriter's Laboratories Fire Resistance Directory (volume 2.)"

JOB NUMBER: \_\_\_\_\_

DRAWN: \_\_\_\_\_

CHECKED: \_\_\_\_\_

ISSUE DATE: \_\_\_\_\_

REVISIONS: \_\_\_\_\_

CONTENTS: \_\_\_\_\_

MECHANICAL PENETRATIONS  
CONCRETE OVER METAL DECK  
2 HR.

SHEET NAME: \_\_\_\_\_

**M.3.2**

SHEET NUMBER: \_\_\_\_\_



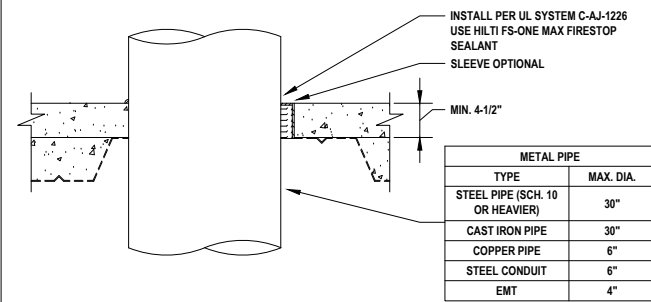

**1**  
**M.3.3**  
METAL PIPE THROUGH CONCRETE OVER METAL DECKING (3-HR.)  
NOT TO SCALE

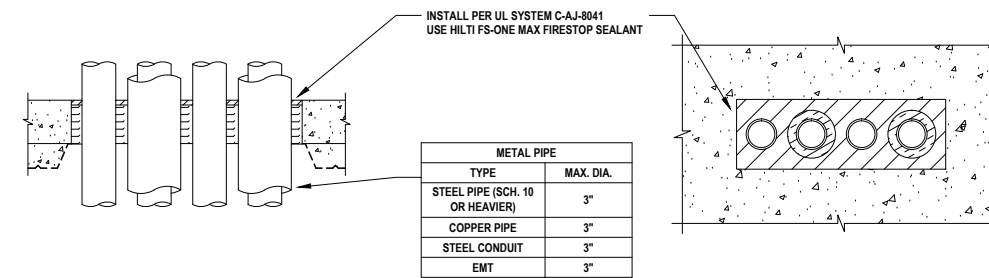

**2**  
**M.3.3**  
MULTIPLE METAL PIPES THROUGH CONCRETE OVER METAL DECKING (3-HR.)  
NOT TO SCALE

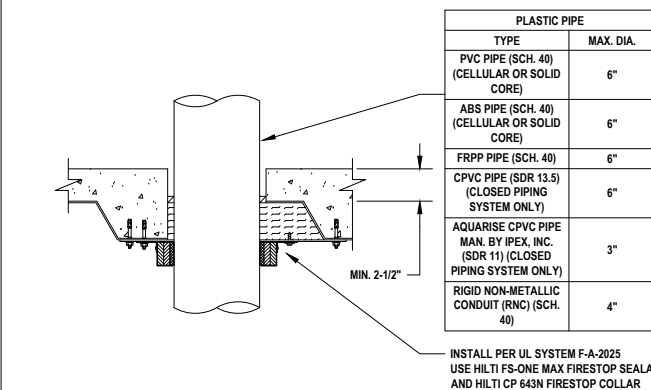

**3**  
**M.3.3**  
PLASTIC PIPE THROUGH CONCRETE OVER METAL DECKING (3-HR.)  
NOT TO SCALE

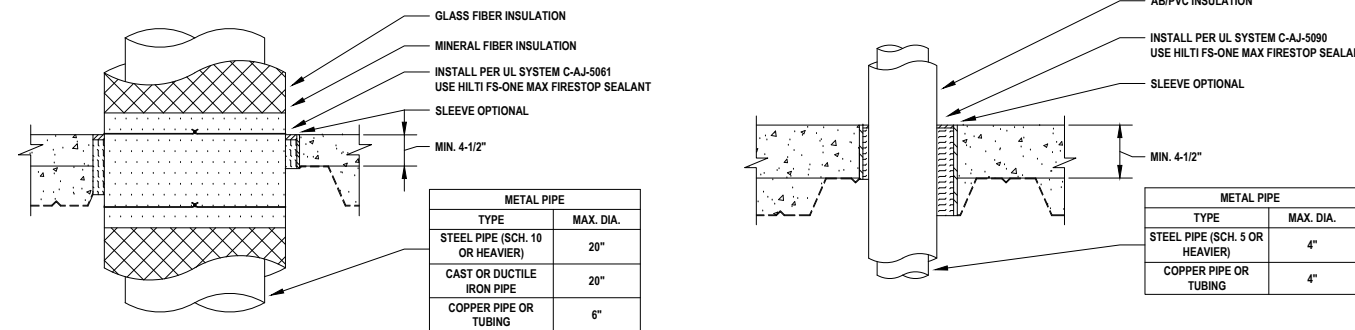

**4**  
**M.3.3**  
METAL PIPE WITH GLASS FIBER INSULATION THROUGH CONCRETE OVER METAL DECKING (3-HR.)  
NOT TO SCALE

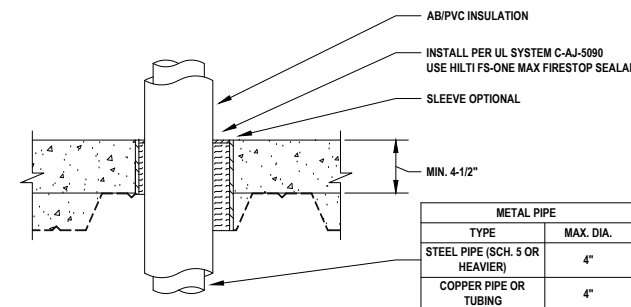

**5**  
**M.3.3**  
METAL PIPE WITH AB/PVC INSULATION THROUGH CONCRETE OVER METAL DECKING (3-HR.)  
NOT TO SCALE

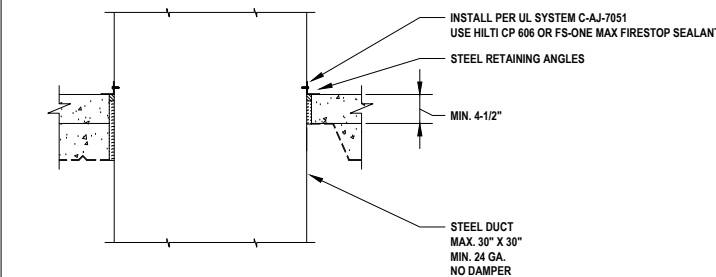

**6**  
**M.3.3**  
METAL DUCT (WITHOUT DAMPER) THROUGH CONCRETE OVER METAL DECKING (3-HR.)  
NOT TO SCALE

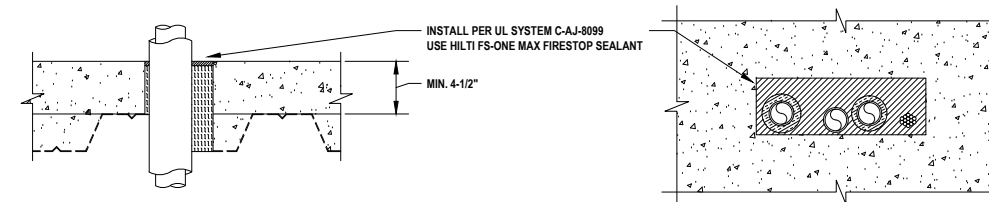

**7**  
**M.3.3**  
MULTIPLE PENETRATIONS THROUGH CONCRETE OVER METAL DECKING (3-HR.)  
NOT TO SCALE

Notes:

- Refer to the following specifications for firestopping.
  - 07 84 00 Firestopping
  - 07 84 13 Penetration Firestopping
  - 22 00 00 Plumbing
  - 23 00 00 HVAC
  - 26 00 00 Electrical
  - 27 06 37 Communication

For Quality Control requirements, refer to the Quality Control portion of the specification.

- Details shown are typical details, containing general information only. Always refer to the full UL system detail for complete system requirements. If field conditions do not match requirements of details, approved alternate details shall be utilized. Design requirements, field conditions and dimensions need to be verified for compliance with the details, including but not limited to the following:

- \* Fire Rating (F-Rating)
- \* Temperature Rating (T-Rating)
- \* Leakage Rating (L-Rating)
- \* Water Rating (W-Rating)
- \* Annular Space
- \* Percent Fill
- \* Movement
- \* Type and thickness of fire-rated construction.

- If alternate details matching the field conditions are not available, manufacturer's engineering judgment drawings are acceptable. Contact Hilti Inc. for alternative systems or Engineering Judgment (800-879-8000) Drawings shall follow the International Firestop Council (IFC) Guidelines for Evaluating Firestop Systems Engineering Judgments.

4. References:

- \* 2013 Underwriter's Laboratories Fire Resistance Directory, Volumes 1 & 2
- \* NFPA 101 Life Safety Code
- \* NFPA 70 - National Electric Code
- \* All governing local and regional building codes

- Firestop System installation must meet requirements of ASTM E-814 (UL 1479) tested assemblies that provide a fire rating equal to that of construction being penetrated.

- All rated through-penetration assemblies shall be prominently labeled with a Hilti Firestop Label equipped with a QR code with the following information:

- \* Warning! - Do Not Disturb
- \* Through Penetration Firestop System
- \* UL System # \* Product(s) used
- \* Hourly Rating (F-Rating)
- \* Installation Date
- \* Contractor's Name

- For outlet boxes requiring protection, use only Wall Opening Protective Materials, category CLIV as classified by Underwriter's Laboratories, Fire Resistance Directory (Volume 1.)

<Notes to designer (delete this note after reading and replace with title block information)>  
 1. Any modification to these details could result in an application/system not meeting the UL or Intertek Classification or the intended temperature or fire ratings.  
 2. Details shown are up to date as of February 2015.  
 3. For additional information on the details, refer to the most current "Underwriter's Laboratories Fire Resistance Directory (volume 2.)"

JOB NUMBER: \_\_\_\_\_

DRAWN: \_\_\_\_\_

CHECKED: \_\_\_\_\_

ISSUE DATE: \_\_\_\_\_

REVISIONS: \_\_\_\_\_

CONTENTS: \_\_\_\_\_

MECHANICAL PENETRATIONS  
CONCRETE OVER METAL DECK  
3 HR.

SHEET NAME: \_\_\_\_\_

**M.3.3**

SHEET NUMBER: \_\_\_\_\_

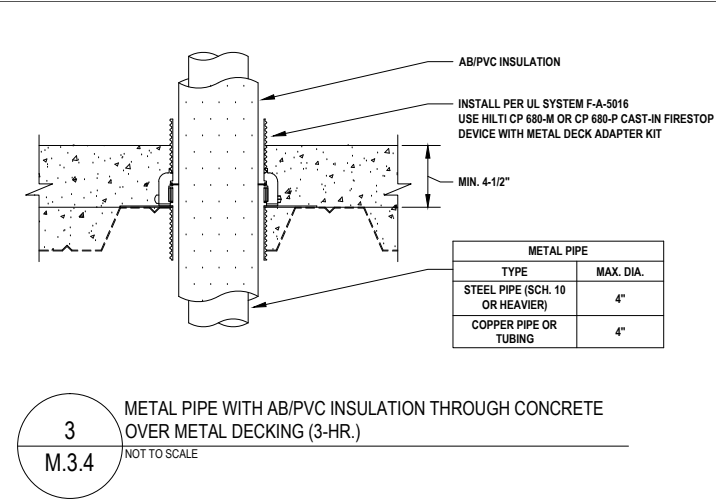
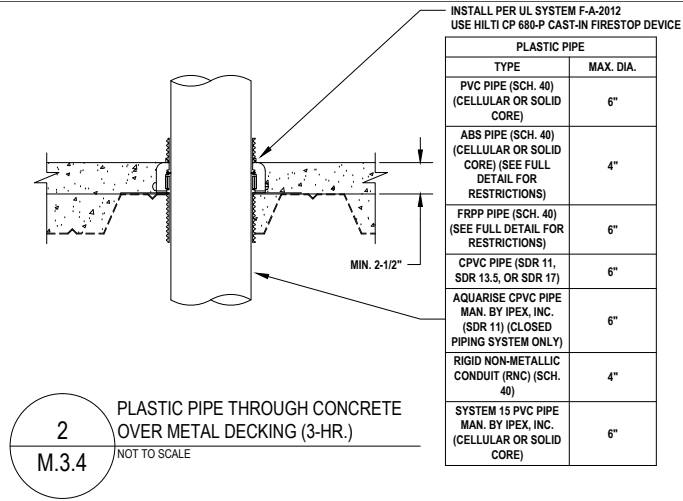
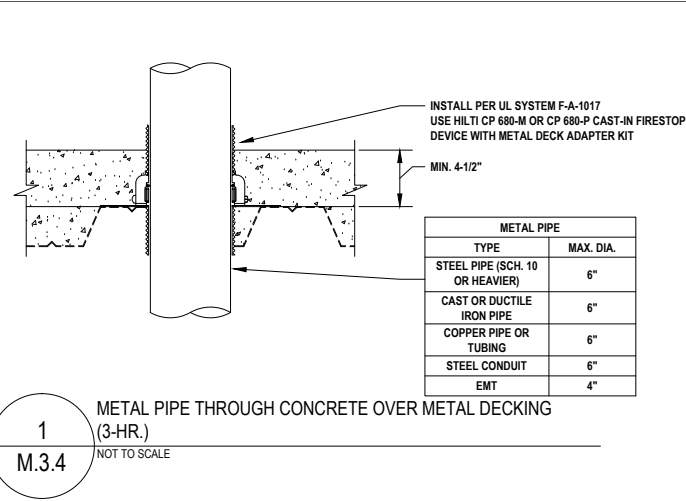

Notes:

- Refer to the following specifications for firestopping.
  - 07 84 00 Firestopping
  - 07 84 13 Penetration Firestopping
  - 22 00 00 Plumbing
  - 23 00 00 HVAC
  - 26 00 00 Electrical
  - 27 06 37 Communication

For Quality Control requirements, refer to the Quality Control portion of the specification.

- Details shown are typical details, containing general information only. Always refer to the full UL system detail for complete system requirements. If field conditions do not match requirements of details, approved alternate details shall be utilized. Design requirements, field conditions and dimensions need to be verified for compliance with the details, including but not limited to the following:
  - \* Fire Rating (F-Rating)
  - \* Temperature Rating (T-Rating)
  - \* Leakage Rating (L-Rating)
  - \* Water Rating (W-Rating)
  - \* Annular Space
  - \* Percent Fill
  - \* Movement
  - \* Type and thickness of fire-rated construction.

- If alternate details matching the field conditions are not available, manufacturer's engineering judgment drawings are acceptable. Contact Hilti Inc. for alternative systems or Engineering Judgment (800-879-8000) Drawings shall follow the International Firestop Council (IFC) Guidelines for Evaluating Firestop Systems Engineering Judgments.

References:

- \* 2013 Underwriter's Laboratories Fire Resistance Directory, Volumes 1 & 2
  - \* NFPA 101 Life Safety Code
  - \* NFPA 70 - National Electric Code
  - \* All governing local and regional building codes
- Firestop System installation must meet requirements of ASTM E-814 (UL 1479) tested assemblies that provide a fire rating equal to that of construction being penetrated.
  - All rated through-penetration assemblies shall be prominently labeled with a Hilti Firestop Label equipped with a QR code with the following information:
    - \* Warning! - Do Not Disturb
    - \* Through Penetration Firestop System
    - \* UL System # \* Product(s) used
    - \* Hourly Rating (F-Rating)
    - \* Installation Date
    - \* Contractor's Name
  - For outlet boxes requiring protection, use only Wall Opening Protective Materials, category CLIV as classified by Underwriter's Laboratories, Fire Resistance Directory (Volume 1.)

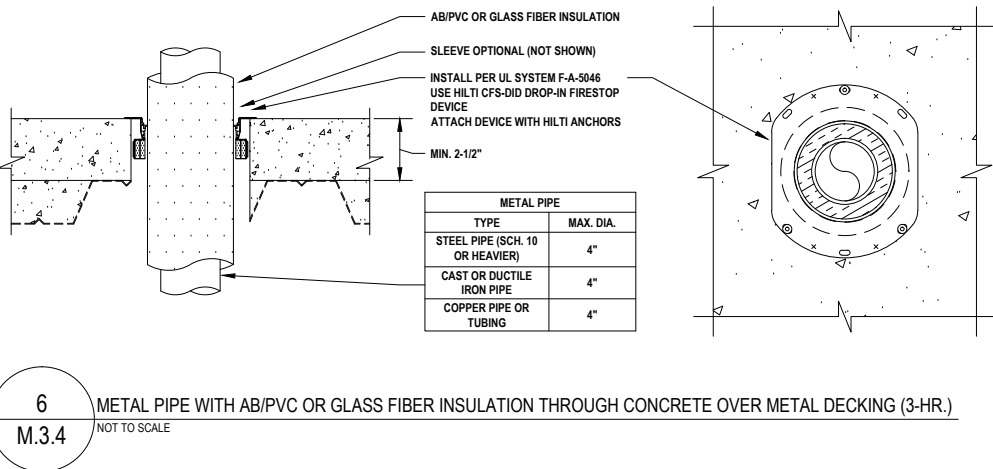
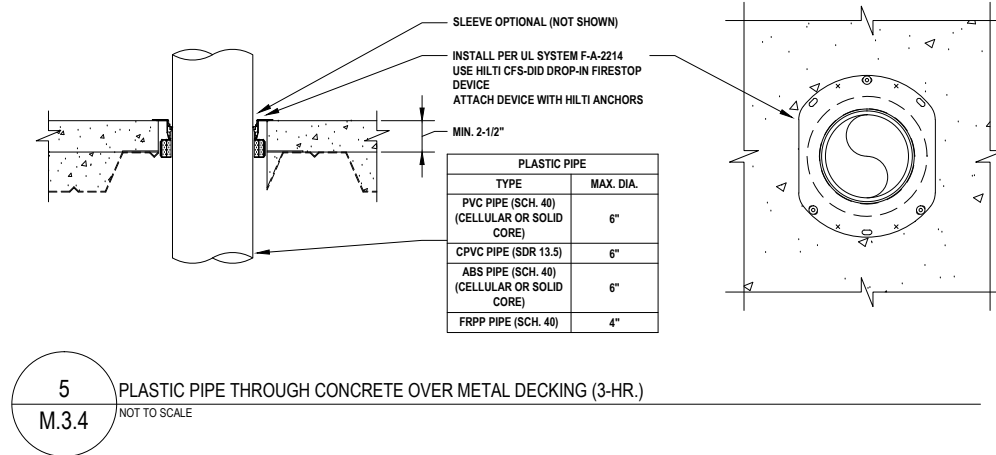
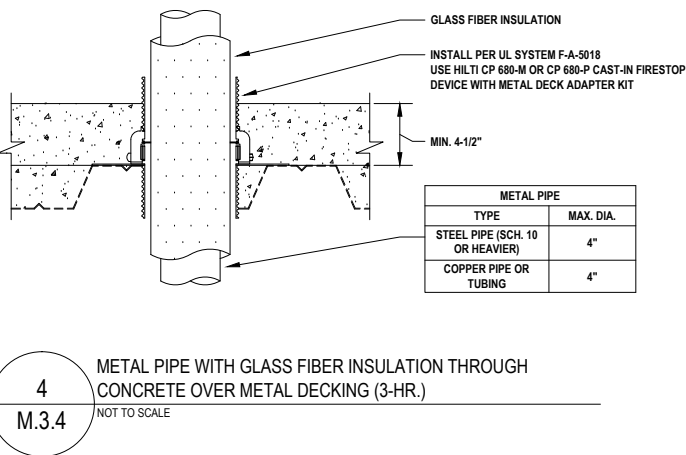

<Notes to designer (delete this note after reading and replace with title block information)>  
 1. Any modification to these details could result in an application/system not meeting the UL or Intertek Classification or the intended temperature or fire ratings.  
 2. Details shown are up to date as of February 2015.  
 3. For additional information on the details, refer to the most current "Underwriter's Laboratories Fire Resistance Directory (volume 2.)"

JOB NUMBER: \_\_\_\_\_

DRAWN: \_\_\_\_\_

CHECKED: \_\_\_\_\_

ISSUE DATE: \_\_\_\_\_

REVISIONS: \_\_\_\_\_

CONTENTS: \_\_\_\_\_

MECHANICAL PENETRATIONS  
CONCRETE OVER METAL DECK  
3 HR.

SHEET NAME: \_\_\_\_\_

**M.3.4**

SHEET NUMBER: \_\_\_\_\_

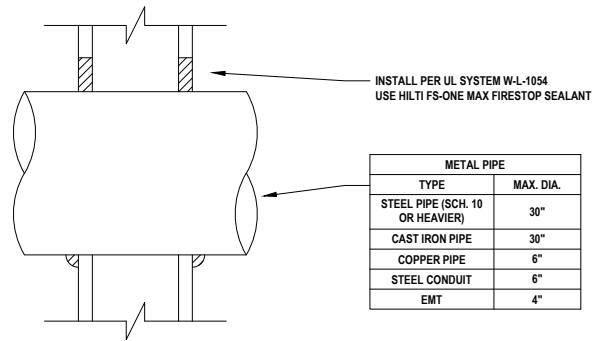

INSTALL PER UL SYSTEM W-L-1054  
USE HILTI FS-ONE MAX FIRESTOP SEALANT

METAL PIPE	
TYPE	MAX. DIA.
STEEL PIPE (SCH. 10 OR HEAVIER)	30"
CAST IRON PIPE	30"
COPPER PIPE	6"
STEEL CONDUIT	6"
EMT	4"

**1**  
M.4.1 METAL PIPE THROUGH GYPSUM WALL ASSEMBLY (1-HR.)  
NOT TO SCALE

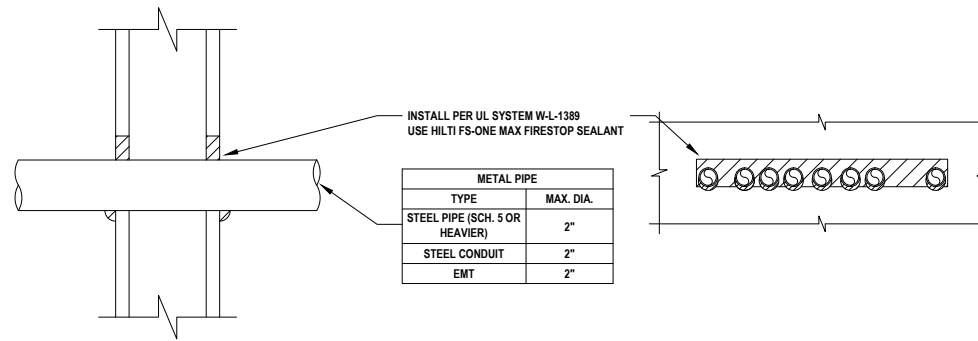

INSTALL PER UL SYSTEM W-L-1389  
USE HILTI FS-ONE MAX FIRESTOP SEALANT

METAL PIPE	
TYPE	MAX. DIA.
STEEL PIPE (SCH. 5 OR HEAVIER)	2"
STEEL CONDUIT	2"
EMT	2"

**2**  
M.4.1 MULTIPLE METAL PIPES THROUGH GYPSUM WALL ASSEMBLY (1-HR.)  
NOT TO SCALE

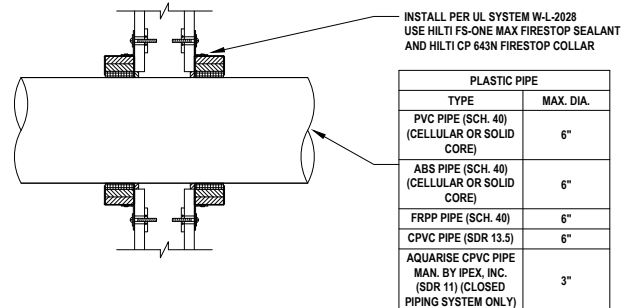

INSTALL PER UL SYSTEM W-L-2028  
USE HILTI FS-ONE MAX FIRESTOP SEALANT  
AND HILTI CP 643N FIRESTOP COLLAR

PLASTIC PIPE	
TYPE	MAX. DIA.
PVC PIPE (SCH. 40) (CELLULAR OR SOLID CORE)	6"
ABS PIPE (SCH. 40) (CELLULAR OR SOLID CORE)	6"
FRPP PIPE (SCH. 40)	6"
CPVC PIPE (SDR 13.5)	6"
AQUARISE CPVC PIPE MAN. BY IPEX, INC. (SDR 11) (CLOSED PIPING SYSTEM ONLY)	3"

**3**  
M.4.1 PLASTIC PIPE THROUGH GYPSUM WALL ASSEMBLY (1-HR.)  
NOT TO SCALE

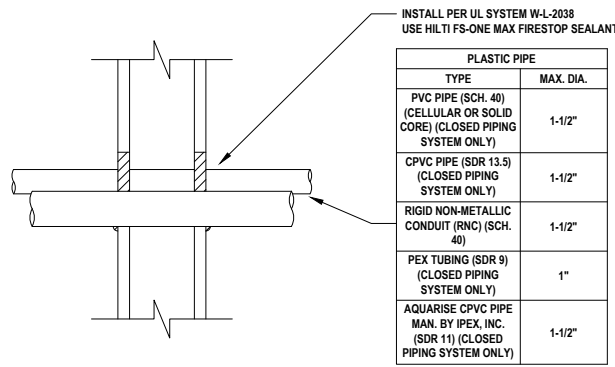

INSTALL PER UL SYSTEM W-L-2038  
USE HILTI FS-ONE MAX FIRESTOP SEALANT

PLASTIC PIPE	
TYPE	MAX. DIA.
PVC PIPE (SCH. 40) (CELLULAR OR SOLID CORE) (CLOSED PIPING SYSTEM ONLY)	1-1/2"
CPVC PIPE (SDR 13.5) (CLOSED PIPING SYSTEM ONLY)	1-1/2"
RIGID NON-METALLIC CONDUIT (RNC) (SCH. 40)	1-1/2"
PEX TUBING (SDR 9) (CLOSED PIPING SYSTEM ONLY)	1"
AQUARISE CPVC PIPE MAN. BY IPEX, INC. (SDR 11) (CLOSED PIPING SYSTEM ONLY)	1-1/2"

**4**  
M.4.1 MULTIPLE PLASTIC PIPES THROUGH GYPSUM WALL ASSEMBLY (1-HR.)  
NOT TO SCALE

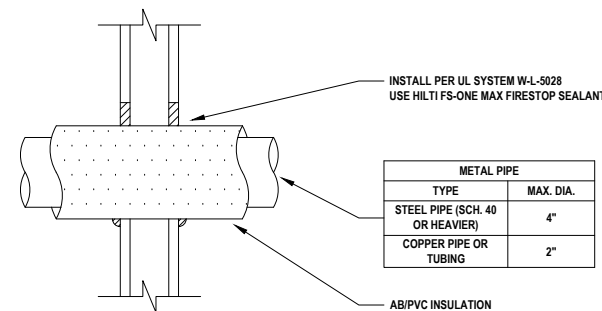

INSTALL PER UL SYSTEM W-L-5028  
USE HILTI FS-ONE MAX FIRESTOP SEALANT

METAL PIPE	
TYPE	MAX. DIA.
STEEL PIPE (SCH. 40 OR HEAVIER)	4"
COPPER PIPE OR TUBING	2"

AB/PVC INSULATION

**5**  
M.4.1 PLASTIC PIPE WITH AB/PVC INSULATION THROUGH GYPSUM WALL ASSEMBLY (1-HR.)  
NOT TO SCALE

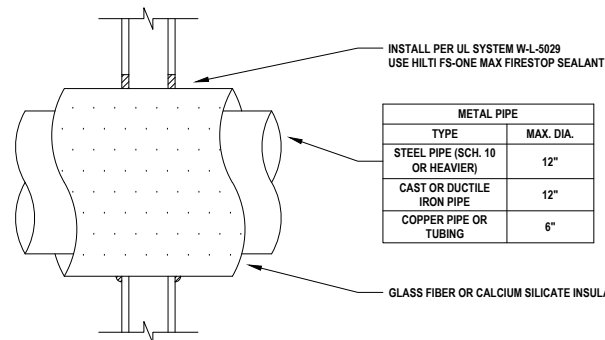

INSTALL PER UL SYSTEM W-L-5029  
USE HILTI FS-ONE MAX FIRESTOP SEALANT

METAL PIPE	
TYPE	MAX. DIA.
STEEL PIPE (SCH. 10 OR HEAVIER)	12"
CAST OR DUCTILE IRON PIPE	12"
COPPER PIPE OR TUBING	6"

GLASS FIBER OR CALCIUM SILICATE INSULATION

**6**  
M.4.1 METAL PIPE WITH GLASS FIBER OR CALCIUM SILICATE INSULATION THROUGH GYPSUM WALL ASSEMBLY (1-HR.)  
NOT TO SCALE

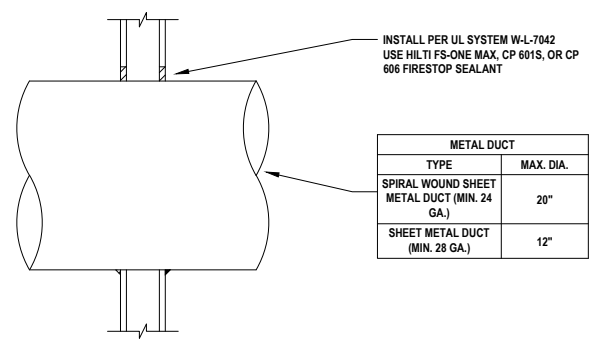

INSTALL PER UL SYSTEM W-L-7042  
USE HILTI FS-ONE MAX, CP 601S, OR CP 606 FIRESTOP SEALANT

METAL DUCT	
TYPE	MAX. DIA.
SPIRAL WOUND SHEET METAL DUCT (MIN. 24 GA.)	20"
SHEET METAL DUCT (MIN. 28 GA.)	12"

**7**  
M.4.1 METAL DUCT (WITHOUT DAMPER) THROUGH GYPSUM WALL ASSEMBLY (1-HR.)  
NOT TO SCALE

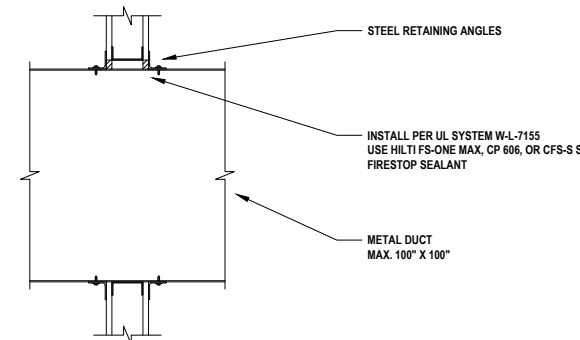

STEEL RETAINING ANGLES

INSTALL PER UL SYSTEM W-L-7155  
USE HILTI FS-ONE MAX, CP 606, OR CFS-S SIL GG FIRESTOP SEALANT

METAL DUCT  
MAX. 100" X 100"

**8**  
M.4.1 METAL DUCT THROUGH GYPSUM WALL ASSEMBLY (1-HR.)  
NOT TO SCALE

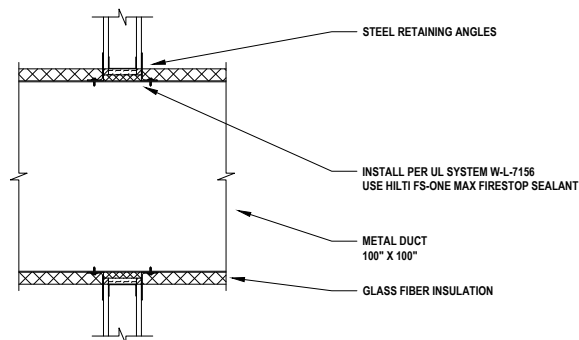

STEEL RETAINING ANGLES

INSTALL PER UL SYSTEM W-L-7156  
USE HILTI FS-ONE MAX FIRESTOP SEALANT

METAL DUCT  
100" X 100"

GLASS FIBER INSULATION

**9**  
M.4.1 METAL DUCT WITH GLASS FIBER INSULATION THROUGH GYPSUM WALL ASSEMBLY (1-HR.)  
NOT TO SCALE

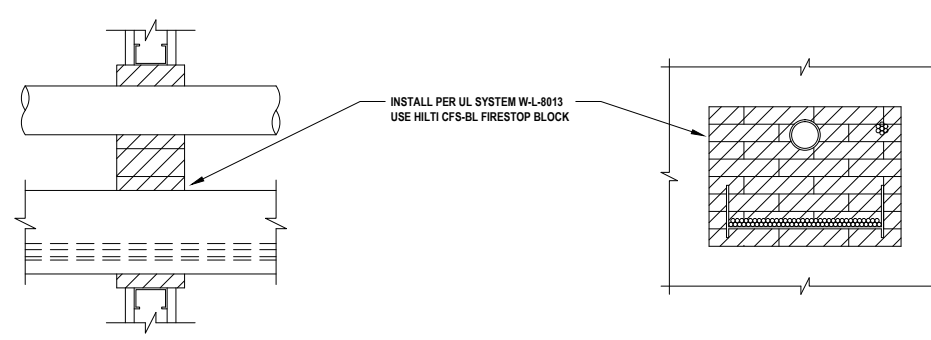

INSTALL PER UL SYSTEM W-L-8013  
USE HILTI CFS-BL FIRESTOP BLOCK

**10**  
M.4.1 MULTIPLE PENETRATIONS THROUGH GYPSUM WALL ASSEMBLY (1-HR.)  
NOT TO SCALE

Notes:

- Refer to the following specifications for firestopping.
  - 07 84 00 Firestopping
  - 07 84 13 Penetration Firestopping
  - 22 00 00 Plumbing
  - 23 00 00 HVAC
  - 26 00 00 Electrical
  - 27 06 37 Communication

For Quality Control requirements, refer to the Quality Control portion of the specification.

- Details shown are typical details, containing general information only. Always refer to the full UL system detail for complete system requirements. If field conditions do not match requirements of details, approved alternate details shall be utilized. Design requirements, field conditions and dimensions need to be verified for compliance with the details, including but not limited to the following:
  - \* Fire Rating (F-Rating)
  - \* Temperature Rating (T-Rating)
  - \* Leakage Rating (L-Rating)
  - \* Water Rating (W-Rating)
  - \* Annular Space
  - \* Percent Fill
  - \* Movement
  - \* Type and thickness of fire-rated construction.

- If alternate details matching the field conditions are not available, manufacturer's engineering judgment drawings are acceptable. Contact Hilti Inc. for alternative systems or Engineering Judgment (800-879-8000) Drawings shall follow the International Firestop Council (IFC) Guidelines for Evaluating Firestop Systems Engineering Judgments.

4. References:

- \* 2013 Underwriter's Laboratories Fire Resistance Directory, Volumes 1 & 2
- \* NFPA 101 Life Safety Code
- \* NFPA 70 - National Electric Code
- \* All governing local and regional building codes

- Firestop System installation must meet requirements of ASTM E-814 (UL 1479) tested assemblies that provide a fire rating equal to that of construction being penetrated.

- All rated through-penetration assemblies shall be prominently labeled with a Hilti Firestop Label equipped with a QR code with the following information:

- \* Warning! - Do Not Disturb
- \* Through Penetration Firestop System
- \* UL System # \* Product(s) used
- \* Hourly Rating (F-Rating)
- \* Installation Date
- \* Contractor's Name

- For outlet boxes requiring protection, use only Wall Opening Protective Materials, category CLIV as classified by Underwriter's Laboratories, Fire Resistance Directory (Volume 1.)

<Notes to designer (delete this note after reading and replace with title block information)>  
 1. Any modification to these details could result in an application/system not meeting the UL or Intertek Classification or the intended temperature or fire ratings.  
 2. Details shown are up to date as of February 2015.  
 3. For additional information on the details, refer to the most current "Underwriter's Laboratories Fire Resistance Directory (volume 2)."

JOB NUMBER: \_\_\_\_\_

DRAWN: \_\_\_\_\_

CHECKED: \_\_\_\_\_

ISSUE DATE: \_\_\_\_\_

REVISIONS: \_\_\_\_\_

CONTENTS: \_\_\_\_\_

MECHANICAL PENETRATIONS  
GYPSUM WALL  
1 HR.

SHEET NAME: \_\_\_\_\_

**M.4.1**

SHEET NUMBER: \_\_\_\_\_

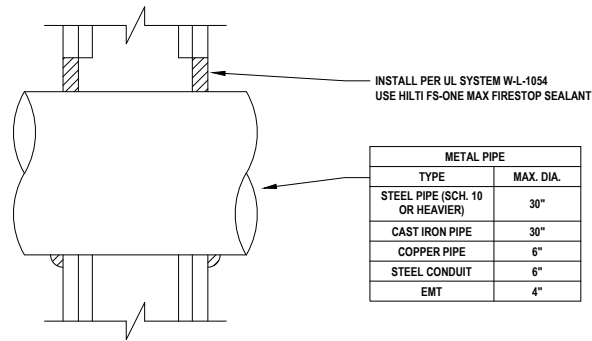

1 METAL PIPE THROUGH GYPSUM WALL ASSEMBLY (2-HR.)  
M.4.2 NOT TO SCALE

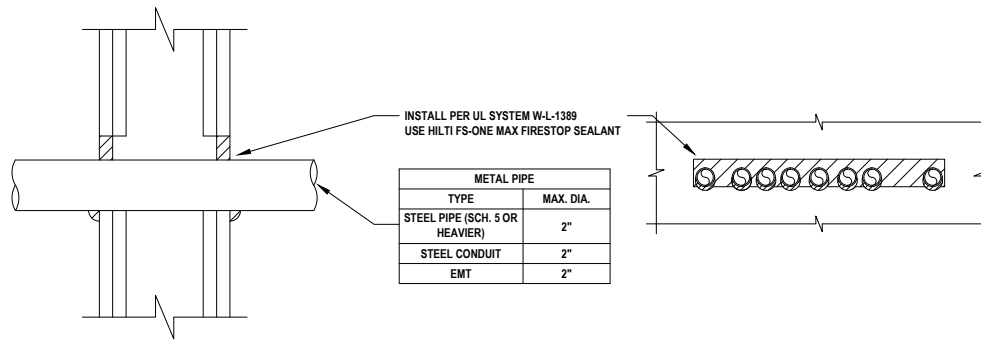

2 MULTIPLE METAL PIPES THROUGH GYPSUM WALL ASSEMBLY (2-HR.)  
M.4.2 NOT TO SCALE

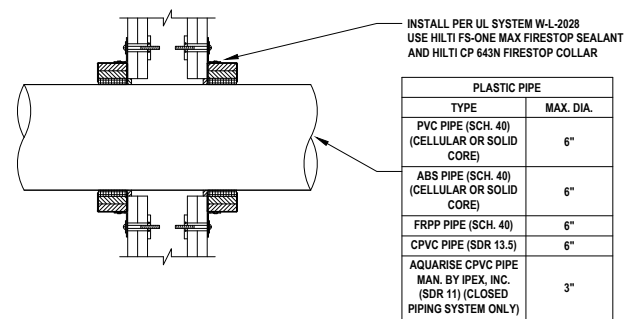

3 PLASTIC PIPE THROUGH GYPSUM WALL ASSEMBLY (2-HR.)  
M.4.2 NOT TO SCALE

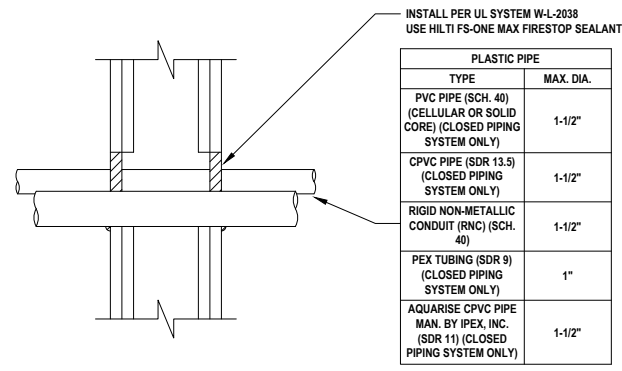

4 MULTIPLE PLASTIC PIPES THROUGH GYPSUM WALL ASSEMBLY (2-HR.)  
M.4.2 NOT TO SCALE

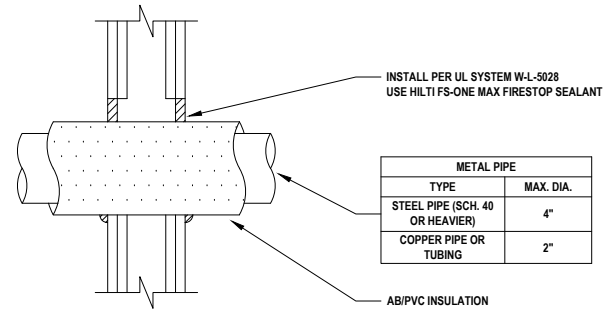

5 PLASTIC PIPE WITH AB/PVC INSULATION THROUGH GYPSUM WALL ASSEMBLY (2-HR.)  
M.4.2 NOT TO SCALE

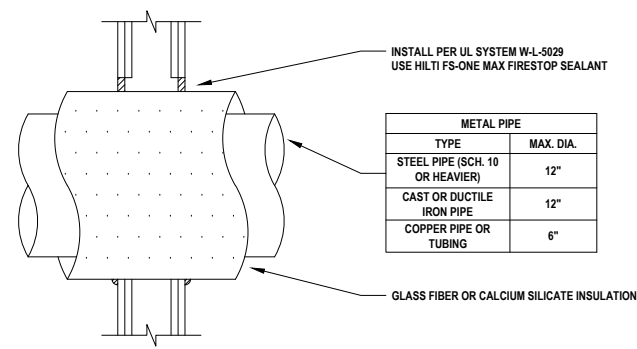

6 METAL PIPE WITH GLASS FIBER OR CALCIUM SILICATE INSULATION THROUGH GYPSUM WALL ASSEMBLY (2-HR.)  
M.4.2 NOT TO SCALE

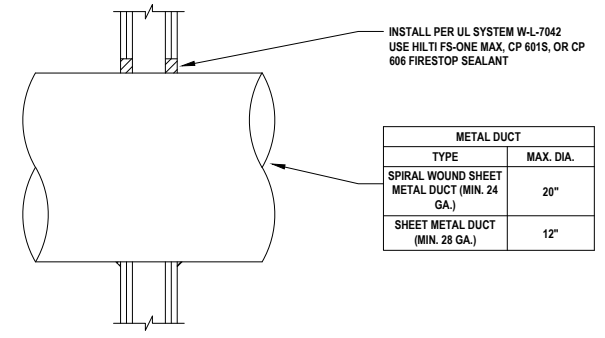

7 METAL DUCT (WITHOUT DAMPER) THROUGH GYPSUM WALL ASSEMBLY (2-HR.)  
M.4.2 NOT TO SCALE

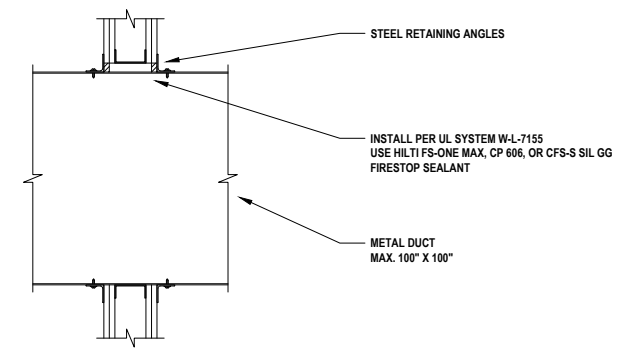

8 METAL DUCT THROUGH GYPSUM WALL ASSEMBLY (2-HR.)  
M.4.2 NOT TO SCALE

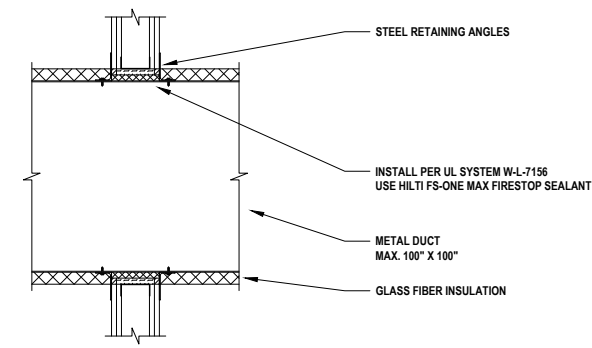

9 METAL DUCT WITH GLASS FIBER INSULATION THROUGH GYPSUM WALL ASSEMBLY (2-HR.)  
M.4.2 NOT TO SCALE

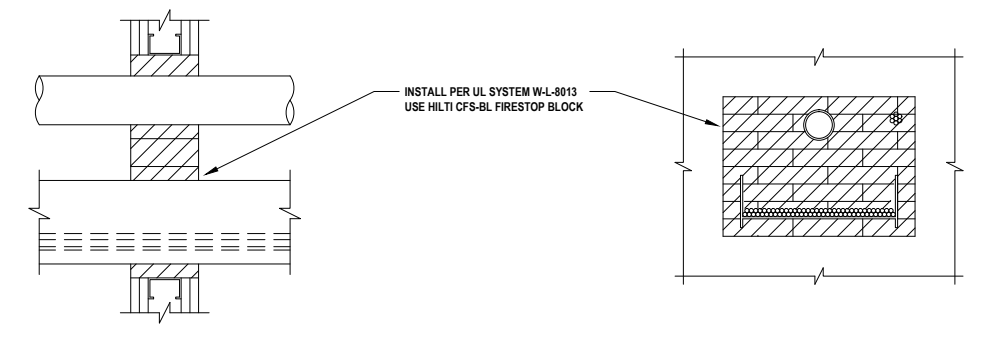

10 MULTIPLE PENETRATIONS THROUGH GYPSUM WALL ASSEMBLY (2-HR.)  
M.4.2 NOT TO SCALE

Notes:

1. Refer to the following specifications for firestopping.
  - a. 07 84 00 Firestopping
  - b. 07 84 13 Penetration Firestopping
  - c. 22 00 00 Plumbing
  - d. 23 00 00 HVAC
  - e. 26 00 00 Electrical
  - f. 27 06 37 Communication

For Quality Control requirements, refer to the Quality Control portion of the specification.

2. Details shown are typical details, containing general information only. Always refer to the full UL system detail for complete system requirements. If field conditions do not match requirements of details, approved alternate details shall be utilized. Design requirements, field conditions and dimensions need to be verified for compliance with the details, including but not limited to the following:
  - \* Fire Rating (F-Rating)
  - \* Temperature Rating (T-Rating)
  - \* Leakage Rating (L-Rating)
  - \* Water Rating (W-Rating)
  - \* Annular Space
  - \* Percent Fill
  - \* Movement
  - \* Type and thickness of fire-rated construction.

3. If alternate details matching the field conditions are not available, manufacturer's engineering judgment drawings are acceptable. Contact Hilti Inc. for alternative systems or Engineering Judgment (800-879-8000) Drawings shall follow the International Firestop Council (IFC) Guidelines for Evaluating Firestop Systems Engineering Judgments.

4. References:
  - \* 2013 Underwriter's Laboratories Fire Resistance Directory, Volumes 1 & 2
  - \* NFPA 101 Life Safety Code
  - \* NFPA 70 - National Electric Code
  - \* All governing local and regional building codes

5. Firestop System installation must meet requirements of ASTM E-814 (UL 1479) tested assemblies that provide a fire rating equal to that of construction being penetrated.

6. All rated through-penetration assemblies shall be prominently labeled with a Hilti Firestop Label equipped with a QR code with the following information:
  - \* Warning! - Do Not Disturb
  - \* Through Penetration Firestop System
  - \* UL System # \* Product(s) used
  - \* Hourly Rating (F-Rating)
  - \* Installation Date
  - \* Contractor's Name

7. For outlet boxes requiring protection, use only Wall Opening Protective Materials, category CLIV as classified by Underwriter's Laboratories, Fire Resistance Directory (Volume 1.)

<Notes to designer (delete this note after reading and replace with title block information)>  
 1. Any modification to these details could result in an application/system not meeting the UL or Intertek Classification or the intended temperature or fire ratings.  
 2. Details shown are up to date as of February 2015.  
 3. For additional information on the details, refer to the most current "Underwriter's Laboratories Fire Resistance Directory (volume 2.)"

JOB NUMBER: \_\_\_\_\_

DRAWN: \_\_\_\_\_

CHECKED: \_\_\_\_\_

ISSUE DATE: \_\_\_\_\_

REVISIONS: \_\_\_\_\_

CONTENTS: \_\_\_\_\_

MECHANICAL PENETRATIONS  
GYPSUM WALL  
2 HR.

SHEET NAME: \_\_\_\_\_

**M.4.2**

SHEET NUMBER: \_\_\_\_\_