

1
M.3.3 METAL PIPE THROUGH CONCRETE OVER METAL DECKING (3-HR.)
NOT TO SCALE

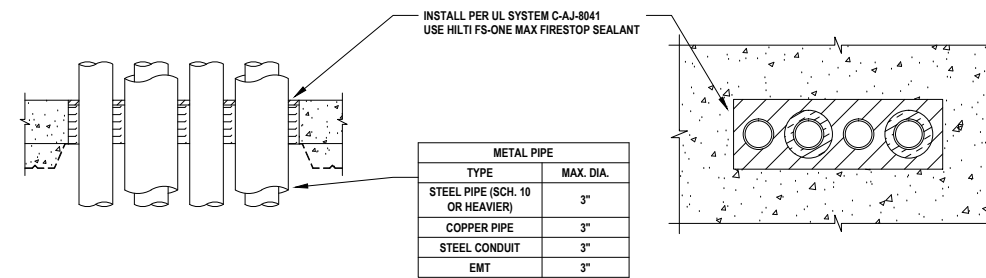

2
M.3.3 MULTIPLE METAL PIPES THROUGH CONCRETE OVER METAL DECKING (3-HR.)
NOT TO SCALE

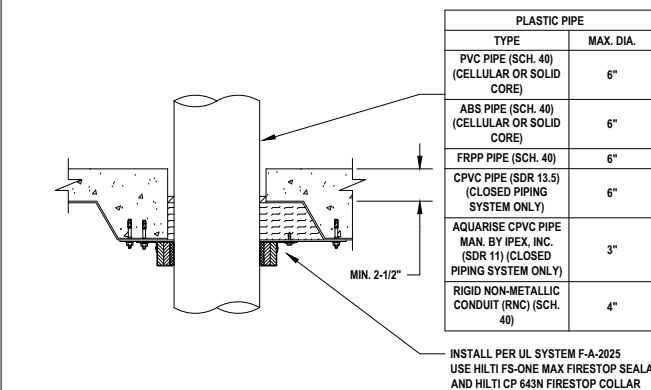

3
M.3.3 PLASTIC PIPE THROUGH CONCRETE OVER METAL DECKING (3-HR.)
NOT TO SCALE

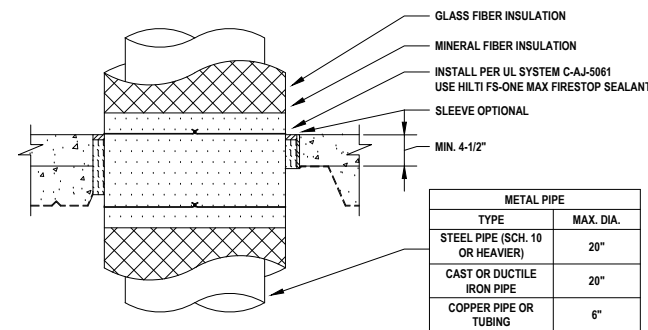

4
M.3.3 METAL PIPE WITH GLASS FIBER INSULATION THROUGH CONCRETE OVER METAL DECKING (3-HR.)
NOT TO SCALE

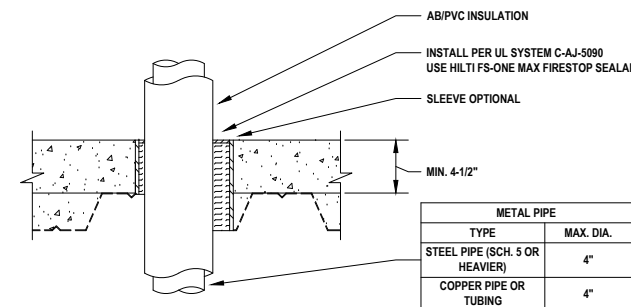

5
M.3.3 METAL PIPE WITH AB/PVC INSULATION THROUGH CONCRETE OVER METAL DECKING (3-HR.)
NOT TO SCALE

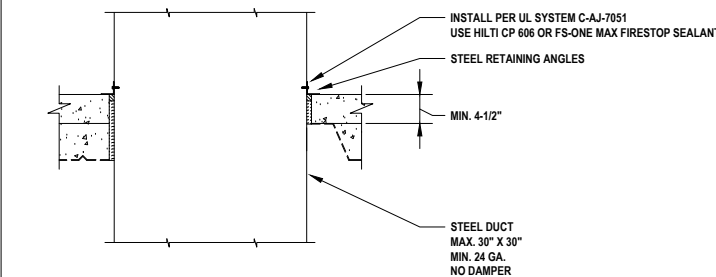

6
M.3.3 METAL DUCT (WITHOUT DAMPER) THROUGH CONCRETE OVER METAL DECKING (3-HR.)
NOT TO SCALE

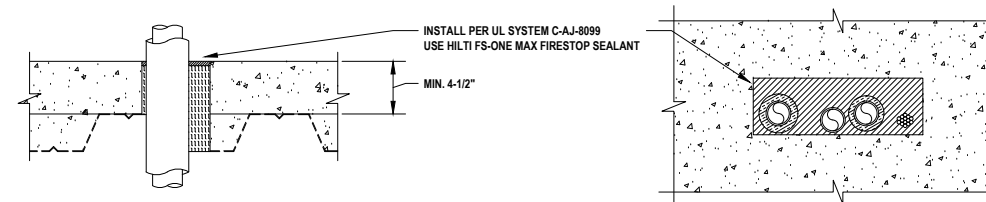

7
M.3.3 MULTIPLE PENETRATIONS THROUGH CONCRETE OVER METAL DECKING (3-HR.)
NOT TO SCALE

Notes:

- Refer to the following specifications for firestopping.
 - 07 84 00 Firestopping
 - 07 84 13 Penetration Firestopping
 - 22 00 00 Plumbing
 - 23 00 00 HVAC
 - 26 00 00 Electrical
 - 27 06 37 Communication

For Quality Control requirements, refer to the Quality Control portion of the specification.

- Details shown are typical details, containing general information only. Always refer to the full UL system detail for complete system requirements. If field conditions do not match requirements of details, approved alternate details shall be utilized. Design requirements, field conditions and dimensions need to be verified for compliance with the details, including but not limited to the following:

- * Fire Rating (F-Rating)
- * Temperature Rating (T-Rating)
- * Leakage Rating (L-Rating)
- * Water Rating (W-Rating)
- * Annular Space
- * Percent Fill
- * Movement
- * Type and thickness of fire-rated construction.

- If alternate details matching the field conditions are not available, manufacturer's engineering judgment drawings are acceptable. Contact Hilti Inc. for alternative systems or Engineering Judgment (800-879-8000) Drawings shall follow the International Firestop Council (IFC) Guidelines for Evaluating Firestop Systems Engineering Judgments.

4. References:

- * 2013 Underwriter's Laboratories Fire Resistance Directory, Volumes 1 & 2
- * NFPA 101 Life Safety Code
- * NFPA 70 - National Electric Code
- * All governing local and regional building codes

- Firestop System installation must meet requirements of ASTM E-814 (UL 1479) tested assemblies that provide a fire rating equal to that of construction being penetrated.

- All rated through-penetration assemblies shall be prominently labeled with a Hilti Firestop Label equipped with a QR code with the following information:

- * Warning! - Do Not Disturb
- * Through Penetration Firestop System
- * UL System # * Product(s) used
- * Hourly Rating (F-Rating)
- * Installation Date
- * Contractor's Name

- For outlet boxes requiring protection, use only Wall Opening Protective Materials, category CLIV as classified by Underwriter's Laboratories, Fire Resistance Directory (Volume 1.)

<Notes to designer (delete this note after reading and replace with title block information)>
 1. Any modification to these details could result in an application/system not meeting the UL or Intertek Classification or the intended temperature or fire ratings.
 2. Details shown are up to date as of February 2015.
 3. For additional information on the details, refer to the most current "Underwriter's Laboratories Fire Resistance Directory (volume 2.)"

JOB NUMBER: _____

DRAWN: _____

CHECKED: _____

ISSUE DATE: _____

REVISIONS: _____

CONTENTS: _____

MECHANICAL PENETRATIONS
CONCRETE OVER METAL DECK
3 HR.

SHEET NAME: _____

M.3.3

SHEET NUMBER: _____

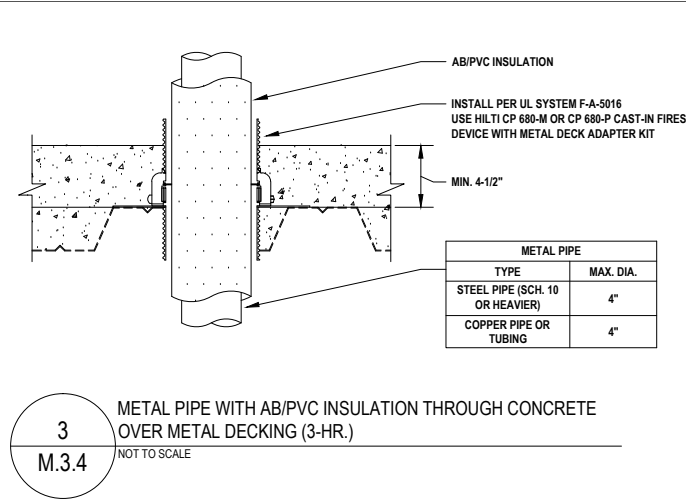
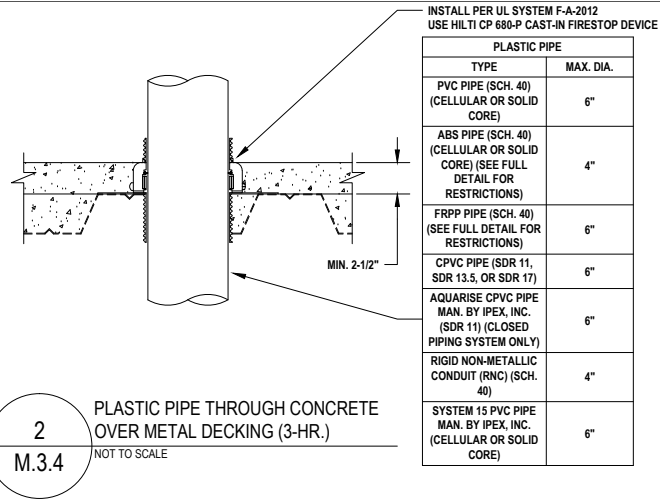
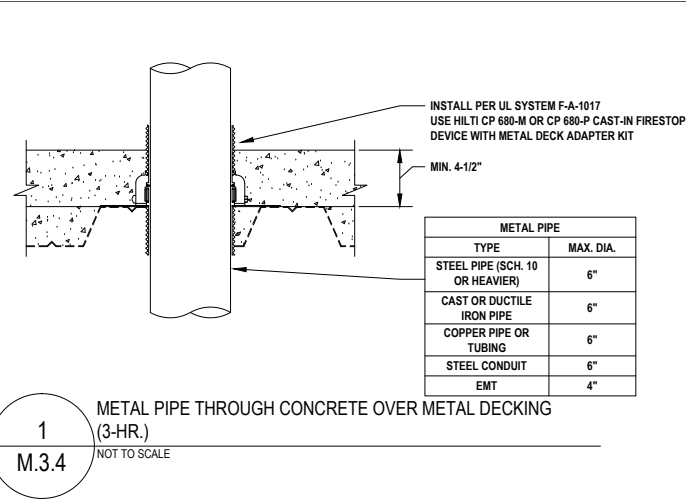

Notes:

1. Refer to the following specifications for firestopping.
 - a. 07 84 00 Firestopping
 - b. 07 84 13 Penetration Firestopping
 - c. 22 00 00 Plumbing
 - d. 23 00 00 HVAC
 - e. 26 00 00 Electrical
 - f. 27 06 37 Communication

For Quality Control requirements, refer to the Quality Control portion of the specification.

2. Details shown are typical details, containing general information only. Always refer to the full UL system detail for complete system requirements. If field conditions do not match requirements of details, approved alternate details shall be utilized. Design requirements, field conditions and dimensions need to be verified for compliance with the details, including but not limited to the following:
 - * Fire Rating (F-Rating)
 - * Temperature Rating (T-Rating)
 - * Leakage Rating (L-Rating)
 - * Water Rating (W-Rating)
 - * Annular Space
 - * Percent Fill
 - * Movement
 - * Type and thickness of fire-rated construction.

3. If alternate details matching the field conditions are not available, manufacturer's engineering judgment drawings are acceptable. Contact Hilti Inc. for alternative systems or Engineering Judgment (800-879-8000) Drawings shall follow the International Firestop Council (IFC) Guidelines for Evaluating Firestop Systems Engineering Judgments.

4. References:
 - * 2013 Underwriter's Laboratories Fire Resistance Directory, Volumes 1 & 2
 - * NFPA 101 Life Safety Code
 - * NFPA 70 - National Electric Code
 - * All governing local and regional building codes
5. Firestop System installation must meet requirements of ASTM E-814 (UL 1479) tested assemblies that provide a fire rating equal to that of construction being penetrated.
6. All rated through-penetration assemblies shall be prominently labeled with a Hilti Firestop Label equipped with a QR code with the following information:
 - * Warning! - Do Not Disturb
 - * Through Penetration Firestop System
 - * UL System # * Product(s) used
 - * Hourly Rating (F-Rating)
 - * Installation Date
 - * Contractor's Name
7. For outlet boxes requiring protection, use only Wall Opening Protective Materials, category CLIV as classified by Underwriter's Laboratories, Fire Resistance Directory (Volume 1.)

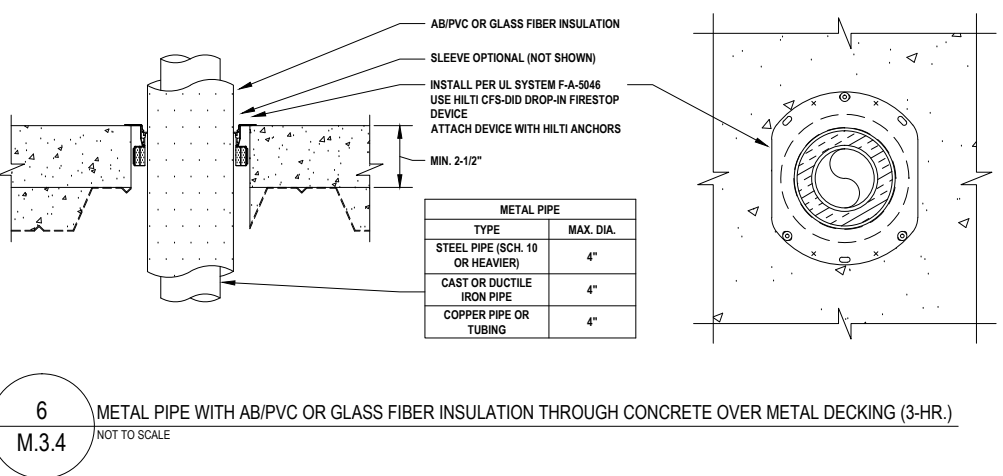
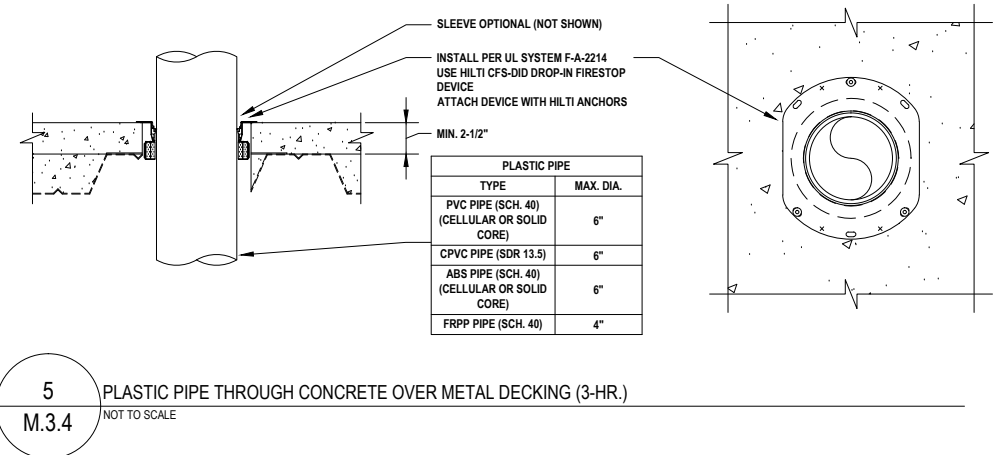
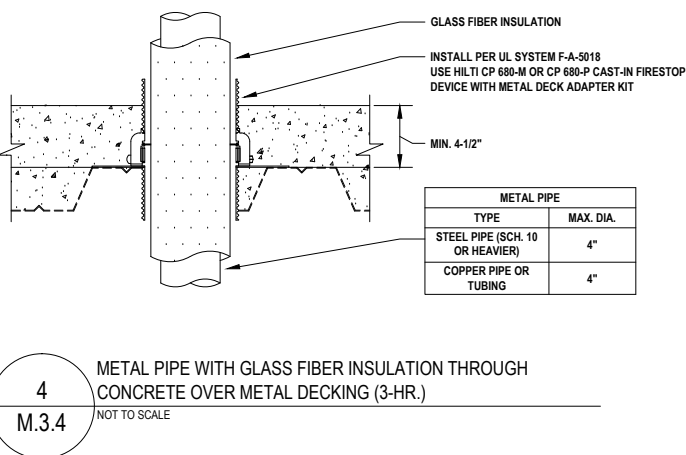

<Notes to designer (delete this note after reading and replace with title block information)>
 1. Any modification to these details could result in an application/system not meeting the UL or Intertek Classification or the intended temperature or fire ratings.
 2. Details shown are up to date as of February 2015.
 3. For additional information on the details, refer to the most current "Underwriter's Laboratories Fire Resistance Directory (volume 2.)"

JOB NUMBER: _____

DRAWN: _____

CHECKED: _____

ISSUE DATE: _____

REVISIONS: _____

CONTENTS: _____

MECHANICAL PENETRATIONS
CONCRETE OVER METAL DECK
3 HR.

SHEET NAME: _____

M.3.4

SHEET NUMBER: _____