



Classified by
Underwriters Laboratories, Inc.
to UL 2079 and CAN/ULC-S115

System No. HW-D-0880

HWD0880

ANSI/UL2079	CAN/ULC S115
Assembly Ratings — 1 and 2 Hr (See Item 2)	F Rating — 1 and 2 Hr (See Item 2)
Nominal Joint Widths — 7/8, 1 or 1-5/8 In (See Item 3)	FT Rating — 1 and 2 Hr (See Item 2)
Class II or III Movement Capabilities — 62% Compression or Extension, 86% Compression or Extension or 92% Compression only (see Item 3-Table 1 below)	FH Rating — 1 and 2 Hr (See Item 2)
L Rating at Ambient — Less than 1 CFM/Lin Ft	FTH Rating — 1 and 2 Hr (See Item 2)
L Rating at 400°F — Less than 1 CFM/Lin Ft	Nominal Joint Widths - 22, 25 or 41 mm (See Item 3)
	Class II or III Movement Capabilities — 62% Compression or Extension, 86% Compression or Extension or 92% Compression only (see Item 3-Table 1 below)
	L Rating at Ambient — Less than 1.55 L/s/mt
	L Rating at 204°F — Less than 1.55 L/s/mt

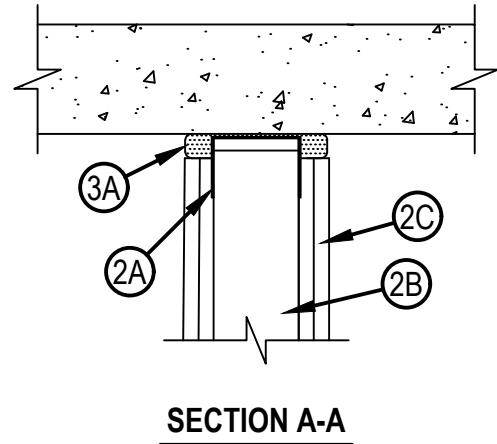
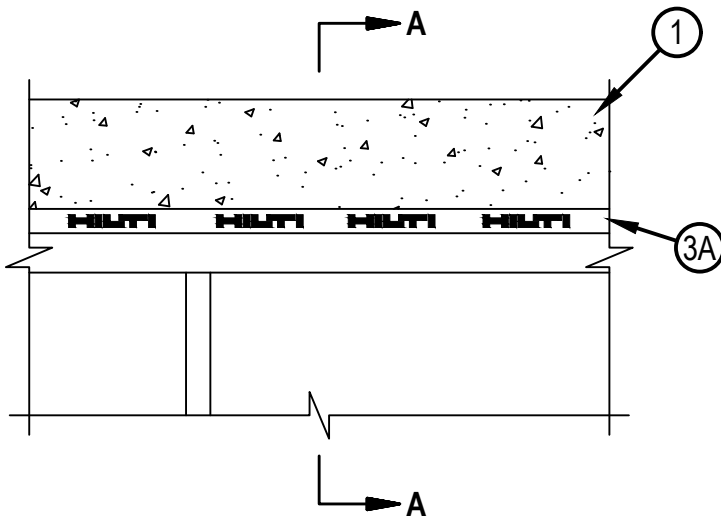

1. Floor Assembly — Min 4-1/2 in. (114 mm) thick steel-reinforced lightweight or normal weight (100-150 pcf or 1600-2400 kg/m³) structural concrete. Floor may also be constructed of any min 6 in. (152 mm) thick UL Classified hollow-core Precast Concrete Units*
See Precast Concrete Units (CFTV) category in the Fire Resistance Directory for names of manufacturers.
2. Wall Assembly — The 1 or 2 h fire-rated gypsum board /steel stud wall assembly shall be constructed of the materials and in the manner specified in the individual U400, V400 or W400 Series Wall and Partition Design in the UL Fire Resistance Directory and shall include the following construction features:
 - A. Steel Floor and Ceiling Runners — Floor and ceiling runners of wall assembly shall consist of min No. 25 gauge galv steel channels sized to accommodate steel studs (Item 2B). Flange height of ceiling runner shall be min 1/4 in. (6 mm) greater than max extended joint width. Ceiling runner secured to floor assembly with steel masonry anchors or steel fasteners spaced max 24 in. (610 mm) OC.



Reproduced by HILTI, Inc. Courtesy of
Underwriters Laboratories, Inc.
October 2, 2024

System No. HW-D-0880

HWD0880

- A1. Light Gauge Framing* — Slotted Ceiling Runner — As an alternate to the ceiling runner in Item 2A, slotted ceiling runner to consist of galv steel channel with slotted flanges sized to accommodate steel studs (Item 2B). Slotted Ceiling runner secured to floor assembly with steel masonry anchors or steel fasteners spaced max 24 in. (610 mm) OC.
 CEMCO, LLC — CST
 CLARKDIETRICH BUILDING SYSTEMS — Types SLT, SLT-H
 MARINO/WARE, DIV OF WARE INDUSTRIES INC — Type SLT
 METAL-LITE INC — The System
 SCAFCO STEEL STUD MANUFACTURING CO — Slotted Track
 TELLING INDUSTRIES L L C — True-Action Deflection Track
- B. Studs — Steel studs to be min 3-1/2 in. (64 mm) wide. Studs cut 3/4 to 1 in. (19 to 25 mm) less in length than assembly height with bottom nesting in and resting on floor runner and with top nesting in ceiling runner without attachment. When slotted ceiling runner (Item 2A1) is used, steel studs secured to slotted ceiling runner with No. 8 by 1/2 in. (13 mm) long wafer head steel screws at mid-height of slot on each side of wall. Stud spacing not to exceed 24 in. (610 mm) OC.
- C. Gypsum Board* — For 1 hr assembly, one layer of 5/8 in. (16 mm) thick gypsum board is required in the individual Wall and Partition Design. For 2 hr assembly, two layers of 5/8 in. (16 mm) thick gypsum board is required in the individual Wall and Partition Design. The screws attaching the gypsum board to studs at the top of the wall shall be located 3-1/2 in. (89 mm) to 5-1/2 in. (138 mm) below the bottom edge of the ceiling runner.

The hourly ratings of the joint system are dependent on the hourly rating of the wall.

3. Joint System — Max separation between the bottom of floor assembly and top of wall is 7/8 in. (22 mm), 1 in (25mm), or 1-5/8 in (41mm). See Item 3-Table 1 for more details. The joint system consists of the following:
- A1. Fill, Void or Cavity Material* — Top Track Seal — Factory supplied foam seal installed over the ceiling runner (Item 2A) prior to attachment to underside of floor unit in accordance with the installation instructions.
 HILTI CONSTRUCTION CHEMICALS, DIV OF HILTI INC — CFS-TTS MD OS or CFS-TTS MD 600 Firestop Top Track Seal

Table 1

Max Nom Joint Width, In. (mm)	Max Movement Capabilities, (% of nominal)		Max Movement, in. (mm)
7/8 (22)	Compression	86%	3/4 (19)
	Extension	86%	3/4 (19)
1 (25)	Compression	62%	5/8 (16)
	Extension	62%	5/8 (16)
1-5/8 (41)	Compression	92%	1-1/2 (38)
	Extension	0%	0

As an alternative to the movement percentages above, the joint system may move freely without restriction to the percentage of movement within the range of a min 1/8 in. (3 mm) to max 1-5/8 in. (41 mm) joint width.

* Indicates such products shall bear the UL or cUL Certification Mark for jurisdictions employing the UL or cUL Certification (such as Canada), respectively.



Hilti Firestop Systems

Reproduced by HILTI, Inc. Courtesy of
 Underwriters Laboratories, Inc.
 October 2, 2024