

**Design No. HI/BPF 120-27**  
**Perimeter Fire Barrier System**  
 Hilti, Inc.  
**Edge of Slab QuickSeal CFS-EOS QS**  
**ASTM E2307, CAN/ULC-S115**

**Table 1**

Edge of Slab Quick Seal, CFS-EOS QS	
F-Rating	2 Hour
T-Rating	43 Minute
L-Rating	< 2.0 SCFM/LF

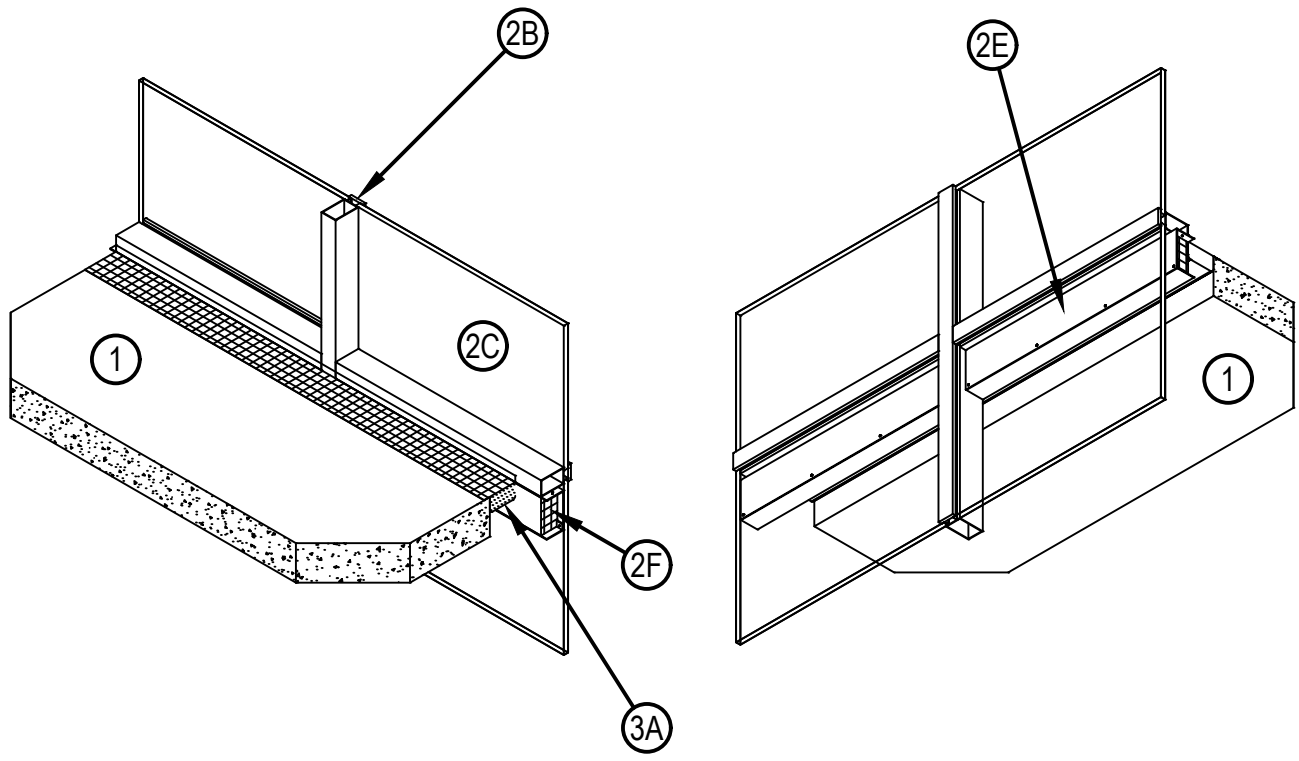

**Figure 1. Isometric Views**

**Table 2. CFS-EOS QS Sizes**

Product	Allowable Joint Width	
	Minimum	Maximum
CFS-EOS QS Small	1-1/2 in.	2 in.
CFS-EOS QS Medium	2 in.	3 in.
CFS-EOS QS Large	3 in.	4 in.

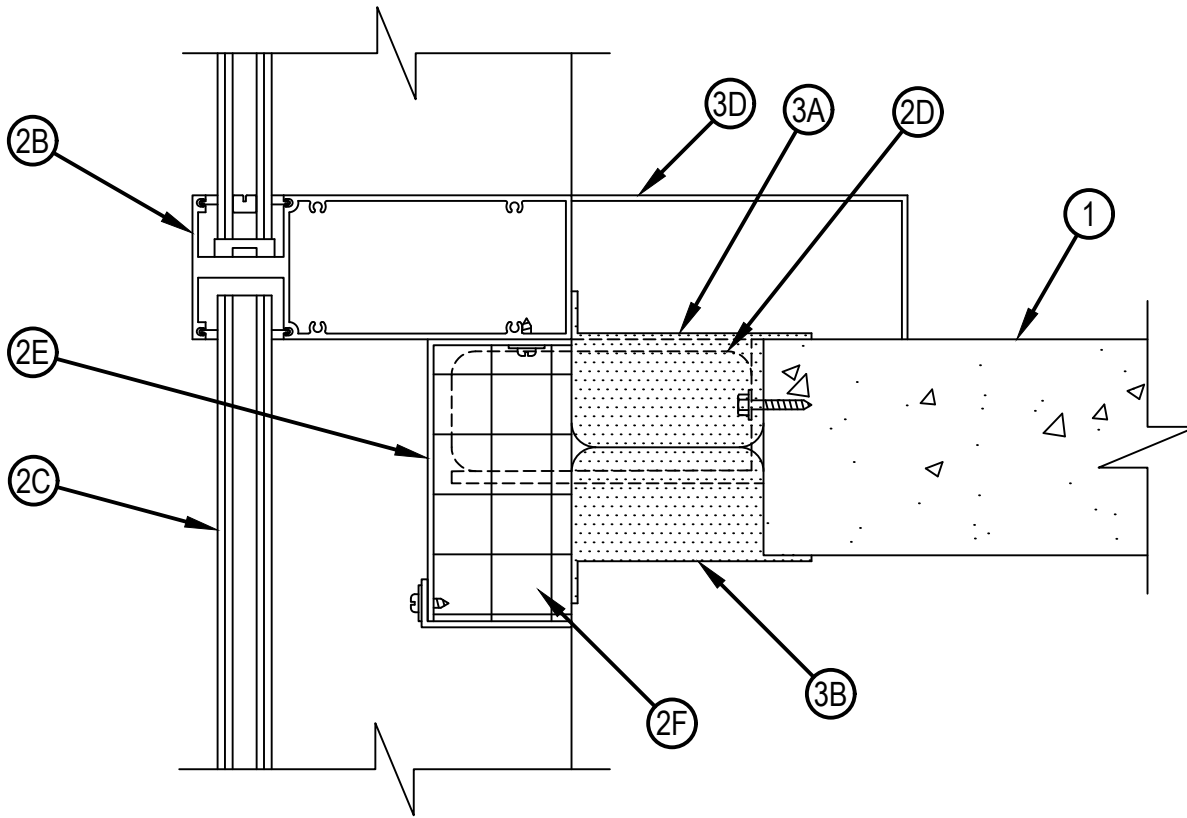

Figure 2. Side Cross-Section

1. CONCRETE FLOOR ASSEMBLY: 2 hour rated concrete floor assembly made from either lightweight or normal weight concrete with a density of 100 to 150 pcf, having a min. thickness of 4-1/2 in. at the joint face. When a longitudinal recess (blockout) is required to contain an architectural joint system, increase concrete floor assembly thickness to maintain a min. thickness of 4-1/2 in. and accommodate depth of blockout formed in the concrete: blockout width unrestricted.
2. CURTAIN WALL ASSEMBLY: The curtain wall assembly shall incorporate the following construction features:
  - A. MOUNTING ATTACHMENT (Not Shown) – Attach aluminum framing (Item 2B) to the structural framing with min. 1/2 in. thick aluminum anchor brackets according to the curtain wall manufacturer's instructions. Connect the mounting attachments to the joint face of the concrete floor assembly (Item 1) according to the curtain wall manufacturer's instructions.
  - B. ALUMINUM FRAMING – Use hollow rectangular aluminum extruded tubing with min. overall dimensions of 0.100 in. thick, 5-1/4 in. deep and 2-1/2 in. wide. Locate mullions (vertical aluminum framing) min. 60 in. oc and space transoms (horizontal aluminum framing) min. 32-1/2 in. oc. For the spandrel region, locate the upper transom (horizontal aluminum framing) even with the top face of the concrete floor assembly (Item 1).

- C. GLASS PANELS – Size and install into aluminum framing (Item 2B) in accordance with the curtain wall manufacturer's instructions. Use min. 1/4 in. thick, clear, heat strengthened (HS) or tempered glass with height and width sized accordingly for the aluminum framing (Item 2B) spacing. OC spacing shall allow glass to be secured to the aluminum framing (Item 2B) between the notched shoulders. Secure glass panels with a thermal break (rubber extrusion), pressure bar (aluminum extrusion), min. 1/4-20 × 5/8 in. long screws, and a snap face (aluminum extrusion).
- D. ALUMINUM ANCHOR BRACKET (Not Shown): Use min. 1/2 in. thick aluminum anchor brackets to serve as part of the mounting attachment (Item 2A) rigidly secured to the aluminum framing (Item 2B) and the concrete floor assembly (Item 1) such that the aluminum anchor is flush with the top face of the concrete floor.
- E. BACKPAN: Create a 6 in. high by 4 in. deep 18 GA galvanized steel backpan to house the curtain wall insulation (Item 2F). Use two L-shaped pieces measuring 4 in. x 6 in. and 4 in. x 1 in., respectively. Attach the 4 in. leg of the L-shaped 18 GA galvanized steel sheet measuring 4 in. x 6 in. to the underside of the floor-level horizontal aluminum framing (Item 2B) with No. 10 self-drilling sheet metal screws spaced maximum 12 in. oc. Apply a bead of Hilti CFS-S SIL GG Firestop Silicone between the horizontal aluminum framing (Item 2B) and the L-shaped 18 GA steel sheet. Attach the 1 in. leg of the 4 in. x 1 in., L-shaped 18 GA galvanized steel sheet to the 6 in. leg of the 4 in. x 6 in., L-shaped 18 GA galvanized steel sheet with No. 10 self-drilling sheet metal screws spaced maximum 12 in. oc. The 4 in. side of the 4 in. x 1 in. L-shaped 18 GA galvanized steel sheet is to be extended such that a 6 in. leg can be bent up and formed into a vertical leg at the ends to secure it to the vertical aluminum framing (Item 2B) on each side with four No. 10 self-drilling sheet metal screws with two screws at the top and two screws at the bottom.
- F. CURTAIN WALL INSULATION: Use only mineral wool certified by an approved third party, bearing a listing label, meeting the following requirements:  
Fill the cavity formed by the backpan (Item 2D) with 2 layers of min. 2 in. thick, 8 pcf, mineral wool curtain wall insulation, tightly fit, compressed at least 1/8 in. in all directions.
3. PERIMETER JOINT PROTECTION: Do not exceed a 4 in. nominal joint width (joint width at installation) (per Table 2). Incorporate the following construction features for the perimeter joint protection (also known as perimeter fire barrier system):
- A. CERTIFIED MANUFACTURER: Hilti Corporation  
CERTIFIED PRODUCT: Edge of Slab QuickSeal CFS-EOS QS  
Compress the appropriately sized Edge of Slab QuickSeal product (per Table 2) into the perimeter joint opening. Remove paper from adhesive and adhere flaps to top side of concrete floor and front face of mullion. Splices (butt joints) in the length of Edge of Slab QuickSeal are to be tightly compressed together (minimum 1/4 in. compression).
- B. CERTIFIED MANUFACTURER: Hilti Corporation  
CERTIFIED PRODUCT: Edge of Slab QuickSeal CFS-EOS QS  
At each vertical aluminum framing (Item 2B), center and install an additional 12 in. length strip of CFS-EOS QS up against bottom of perimeter joint protection with flaps (facing down) adhered to concrete floor and back pan.
- C. CERTIFIED MANUFACTURER: Hilti Corporation  
CERTIFIED PRODUCT: Edge of Slab Waterstop CFS-EOS WS  
(Optional, Not Shown) Use only Hilti Corporation CFS-EOS WS bearing an Intertek Certified Label. Apply 2mm wet thickness over any seams and overlap a min 2 in. onto Edge of Slab QuickSeal, the adjacent curtain wall assembly and concrete floor slab assembly.
- D. JOINT COVER  
Install minimum 0.05 in. (1.29 mm) thick aluminum L-shaped joint cover extending the entire length of the Edge of Slab QuickSeal CFS-EOS QS. The vertical leg of the joint cover must be a minimum of 2.5 in. high and the horizontal leg must extend a minimum 1 in. beyond the joint. Joint cover to be continuously connected to transom via integrated keying function per curtain wall manufacturer's instructions.