



Classified by  
Underwriters Laboratories, Inc.  
to UL 2079 and CAN/ULC-S115

# System No. HW-D-0907

HWD 0907

ANSI/UL2079	CAN/ULC S115
Assembly Ratings — 1 and 2 Hr (See Item 2)	F Rating — 1 and 2 Hr (See Item 2)
Nominal Joint Width — 1 or 1-1/2 In (See Item 3)	FT Rating — 1 and 2 Hr (See Item 2)
Class II or III Movement Capabilities — 50% Compression or Extension or 66% Compression only	FH Rating — 1 and 2 Hr (See Item 2)
L Rating at Ambient — Less than 1 CFM/Lin Ft	FTH Rating — 1 and 2 Hr (See Item 2)
L Rating at 400°F — Less than 1 CFM/Lin Ft	Nominal Joint Width - 25 or 38 mm (See Item 3)
	Class II or III Movement Capabilities — 50% Compression or Extension or 66% Compression only
	L Rating at Ambient — Less than 1.55 L/s/mt
	L Rating at 204°F — Less than 1.55 L/s/mt

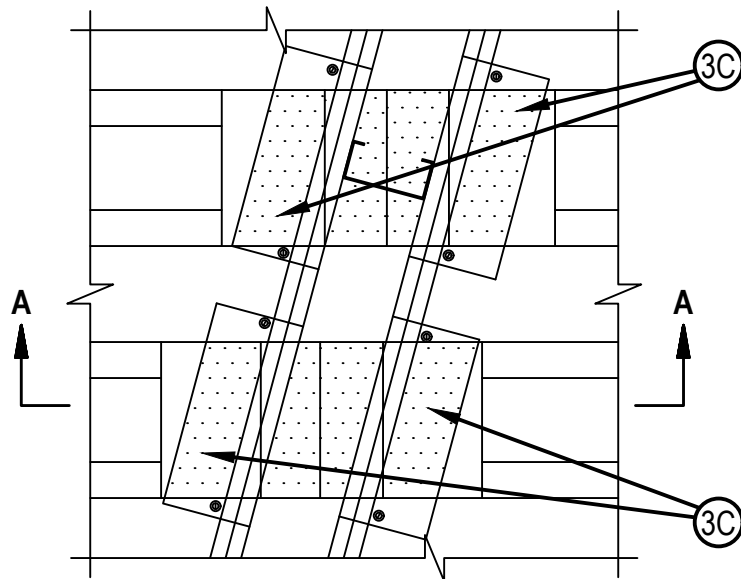

**BOTTOM VIEW**

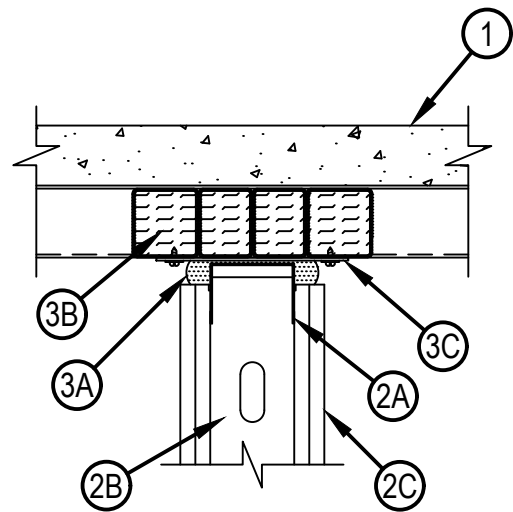

**SECTION A-A**

**CONFIGURATION A**



Reproduced by HILTI, Inc. Courtesy of  
Underwriters Laboratories, Inc.  
June 22, 2023

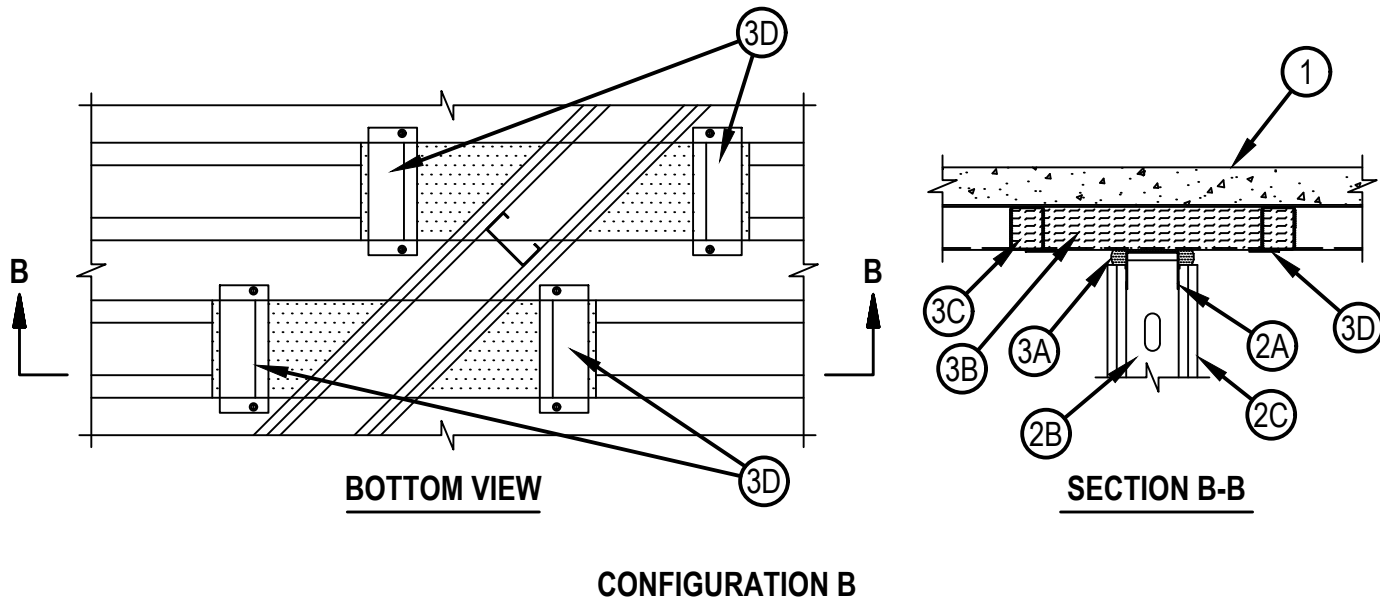

1. Floor Assembly — The fire-rated fluted steel deck/concrete floor assembly shall be constructed of the materials and in the manner described in the individual Floor-Ceiling Design in the UL Fire Resistance Directory. The hourly fire rating of the floor assembly shall be equal to or greater than the hourly fire rating of the wall assembly. The floor assembly shall include the following construction features:
    - A. Steel Floor And Form Units\* — Max 3 in. (76 mm) deep galv fluted floor units.
    - B. Concrete — Min 2-1/2 in. (64 mm) thick reinforced (100-150 pcf or 1600-2400 kg/m<sup>3</sup>) concrete, as measured from the top plane of the floor units.
  2. Wall Assembly — The 1 or 2 h fire-rated gypsum board /steel stud wall assembly shall be constructed of the materials and in the manner specified in the individual U400, V400 or W400 Series Wall and Partition Design in the UL Fire Resistance Directory and shall include the following construction features:
    - A. Steel Floor and Ceiling Runners — Floor and ceiling runners of wall assembly shall consist of min No. 25 gauge galv steel channels sized to accommodate steel studs (Item 2B). Flange height of ceiling runner shall be min 1/4 in. (6 mm) greater than max extended joint width. Ceiling runner installed at an angular traverse of the fluted steel deck and secured to valleys with steel masonry anchors or steel fasteners spaced max 24 in. (610 mm) OC.
    - A1. Light Gauge Framing\* — Slotted Ceiling Runner — As an alternate to Item 1, slotted ceiling runner to consist of galv steel channel with slotted flanges sized to accommodate steel studs (Item 2B). Slotted ceiling runner installed at an angular traverse of the fluted steel deck and secured to valleys with steel masonry anchors, steel fasteners or welds spaced max 24 in. (610 mm) OC.
- BRADY CONSTRUCTION INNOVATIONS INC, DBA SLIPTRACK SYSTEMS — SLP-TRK 325  
 CEMCO, LLC — CST 325  
 CLARKDIETRICH BUILDING SYSTEMS — Types SLT, SLT-H  
 MARINO/WARE, DIV OF WARE INDUSTRIES INC — Type SLT  
 METAL-LITE INC — The System  
 SCAFCO STEEL STUD MANUFACTURING CO — Slotted Track  
 TELLING INDUSTRIES L L C — True-Action Slotted Track

B. Studs — Steel studs to be min 3-5/8 in. (92 mm) wide. Studs cut 3/4 to 1 in. (19 to 25 mm) less in length than assembly height with bottom nesting in and resting on floor runner and with top nesting in ceiling runner without attachment. When slotted ceiling runner (Item 2A1) is used, steel stud secured to slotted ceiling runner with No. 8 by 1/2 in. (13 mm) long wafer head steel screws at mid-height of slot on each side of wall. Stud spacing not to exceed 24 in. (610 mm) OC.

C. Gypsum Board\* — For 1 hr assembly, one layer of 5/8 in. (16mm) thick gypsum board is required in the individual Wall and Partition Design. For 2 hr assembly, two layers of 5/8 in. (16 mm) thick gypsum board as required in the individual Wall and Partition Design. The screws attaching the gypsum board to studs at the top of the wall shall be located 3-1/2 in. (89 mm) to 5-1/2 in. (138 mm) below the bottom edge of the ceiling runner.

The hourly ratings are equal to the hourly rating of the wall assembly.

3. Joint System — Max separation between the bottom of steel floor unit and top of wall is 1 in. (25 mm). The joint system is designed to accommodate a max 50 percent compression or extension from its installed width. . When max separation between the bottom of steel floor unit and top of wall is 1-1/2 in. (38 mm), the joint system is designed to accommodate a max 66% compression only from its installed width. The joint system consists of the following:

A. Fill, Void or Cavity Material\* — Top Track Seal — Factory supplied foam seal installed over the ceiling runner (Item 2A) prior to attachment to the floor assembly in accordance with the installation instructions.

HILTI CONSTRUCTION CHEMICALS, DIV OF HILTI INC — CFS-TTS MD OS or CFS-TTS MD 600 Firestop Top Track Seal

#### Configuration A

B. Forming Material\* — Flute Plug - The fluted area of steel floor is filled continuously with preformed flute plugs. The plug is sized to match deck height and to be friction fit above the ceiling runner extending at least flush with outer surface of the top track seal on both sides of the wall. and are friction fit into the flutes to completely fill the area of the flute above the ceiling runner. Flute plugs to extend a min 2-1/2 in. (64 mm) beyond the ceiling runner.

HILTI CONSTRUCTION CHEMICALS, DIV OF HILTI INC — CFS-TTS MD P1.5, CFS-TTS MD P2, CFS-TTS MD P3 Firestop Top Track Plug

C. Steel Straps — Min 20 ga, 2 in. (51 mm) wide by 10 in. (254 mm) long galvanized steel straps tightly butted to ceiling runner on both sides of wall and attached to steel deck with masonry anchors or steel fasteners on each end.

#### Configuration B

B. Forming Material\* — Flute Cover - The fluted area of steel floor is fitted with preformed flute covers, formed to the shape of the flutes and are friction fit into the flutes to completely fill the area of the flute above the ceiling runner. Flute covers to extend such that the steel strap (Item 3D) overlaps the flute cover a min 1 in. (25 mm).

HILTI CONSTRUCTION CHEMICALS, DIV OF HILTI INC — CFS-TTS MD C1.5, CFS-TTS MD C2, CFS-TTS MD C3 Firestop Top Track Cover

C. Forming Material\* — Flute Plug - The fluted area of steel floor is filled with preformed flute plugs above steel strap and at end of Top Track Cover on both sides of wall. The plug sized to match deck height and to be friction fit and extend a max 1/2 in (13mm) beyond steel straps (Item 3D).

HILTI CONSTRUCTION CHEMICALS, DIV OF HILTI INC — CFS-TTS MD P1.5, CFS-TTS MD P2, CFS-TTS MD P3 Firestop Top Track Plug

D. Steel Straps — Min 20 ga, 4 in. (102 mm) wide by 10 in. (254 mm) long galvanized steel straps located a max 24 in. (610 mm) from center of ceiling runner on both sides of wall and attached to steel deck with masonry anchors or steel fasteners on each end.

\* Indicates such products shall bear the UL or cUL Certification Mark for jurisdictions employing the UL or cUL Certification (such as Canada), respectively.

