



Classified by  
Underwriters Laboratories, Inc.  
to UL 2079 and CAN/ULC-S115

## System No. HW-D-0049

HWD 0049

ANSI/UL2079	CAN/ULC S115
Assembly Ratings — 1 and 2 Hr (See Items 2 and 3)	F Ratings — 1 and 2 Hr (See Items 2 and 3)
Nominal Joint Width - 1 In.	FT Ratings — 1 and 2 Hr (See Items 2 and 3)
Class II Movement Capabilities — 50% Compression or Extension	FH Ratings — 1 and 2 Hr (See Items 2 and 3)
L Rating At Ambient — Less Than 1 CFM/Lin Ft	FTH Ratings — 1 and 2 Hr (See Items 2 and 3)
L Rating At 400°F — Less Than 1 CFM/Lin Ft	Nominal Joint Width – 25.4 mm
	Class II Movement Capabilities — 50% Compression or Extension
	L Rating At Ambient — Less Than 1.55 L/s/Lin m
	L Rating At 204°C — Less Than 1.55 L/s/Lin m

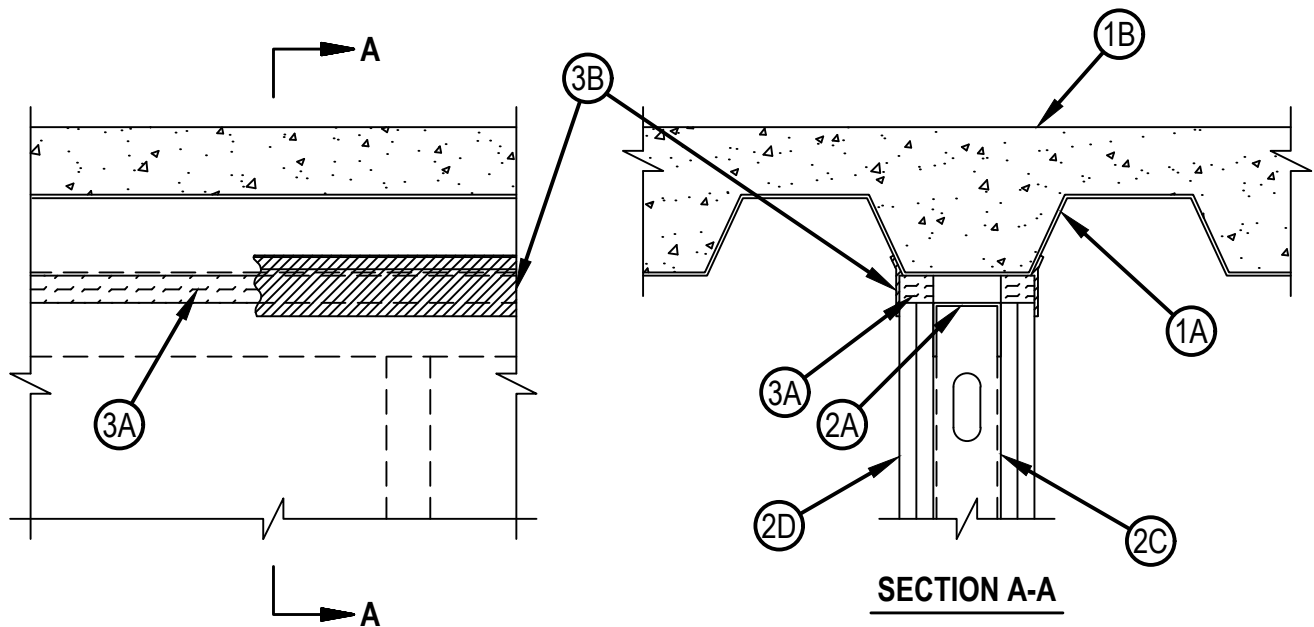

1. Floor Assembly — The fire-rated fluted steel deck/concrete floor assembly shall be constructed of the materials and in the manner described in the individual D700 or D900 Series Floor-Ceiling Design in the UL Fire Resistance Directory and shall include the following construction features:
  - A. Steel Floor And Form Units\* — Max 3 in. (76 mm) deep galv steel fluted units.
    - A1. Steel Floor And Form Units\* — (Not Shown) Composite max 2.5 in. (64 mm) deep galv steel fluted units.  
EPIC METALS CORP — Types "EC" or "Toris C"
    - A2. Steel Floor And Form Units\* — (Not Shown) Composite max 2 in. (51 mm) deep galv steel fluted units.  
NEW MILLENNIUM BUILDING SYSTEMS L L C — Versa-Dek®
    - A3. Steel Floor And Form Units\* (Configuration B) – Composite max 2 in. (51 mm) deep galv steel fluted units.  
Verco Decking Inc – A Nucor Co – Type 2.0D FORMLOK
    - A4. Steel Floor And Form Units\* (Configuration B) – Composite max 2 in. (51 mm) deep galv steel fluted units.  
VULCRAFT, DIV OF NUCOR CORP – Type 2.0D FORMLOK
  - B. Concrete — Min 2-1/2 in. (64 mm) thick reinforced concrete, as measured from the top plane of the floor units.



**Hilti Firestop Systems**

Reproduced by HILTI, Inc. Courtesy of  
Underwriters Laboratories, Inc.  
August 16, 2024

C. Spray-Applied Fire Resistive Materials\* — (Optional) — (Not Shown) — Prior to or after the installation of the steel ceiling runners, Forming Material and Fill, Void or Cavity Material (Items 2A, 3A, 3B) the steel floor units may be sprayed with a min 5/16 in. (8 mm) to max 1-3/4 in. (44 mm) thickness of fire resistive material.

GCP APPLIED TECHNOLOGIES INC — Type MK-6-HY

ISOLATEK INTERNATIONAL — Type 300

1A. Roof Assembly — (Not Shown) — As an alternate to the floor assembly, a fire rated fluted steel deck roof assembly may be used. The roof assembly shall be constructed of the materials and in the manner described in the individual P900 Series Roof-Ceiling Design in the UL Fire Resistance Directory. The hourly rating of the roof assembly shall be equal to or greater than the hourly rating of the wall assembly. The roof assembly shall include the following construction features:

A. Steel Roof Deck — Max 3 in. (76 mm) deep galv steel fluted roof deck.

A1. Steel Floor And Form Units\* — (Not Shown) Composite max 2.5 in. (64 mm) deep galv steel fluted units.

EPIC METALS CORP — Types "Toris C" or "ER2R"

A2. Steel Floor And Form Units\* — (Not Shown) Composite max 2 in. (51 mm) deep galv steel fluted units.

NEW MILLENNIUM BUILDING SYSTEMS L L C — Versa-Dek®

A3. Steel Floor And Form Units\* (Configuration B) — Composite max 2 in. (51 mm) deep galv steel fluted units.

Verco Decking Inc — A Nucor Co — Type 2.0D FORMLOK

A4. Steel Floor And Form Units\* (Configuration B) — Composite max 2 in. (51 mm) deep galv steel fluted units.

VULCRAFT, DIV OF NUCOR CORP — Type 2.0D FORMLOK

B. Roof Insulation — Min 2-1/4 in. (57 mm) thick poured insulating concrete, as measured from the top plane of the floor units.

1B. Roof Assembly — As an alternate to Items 1 and 1A, a fire rated protected fluted steel deck roof assembly may be used. The roof assembly shall be constructed of the materials and in the manner described in the individual P700 Series Roof-Ceiling Design in the UL Fire Resistance Directory. The hourly rating of the roof assembly shall be equal to or greater than the hourly rating of the wall assembly. The roof assembly shall include the following construction features:

A. Steel Roof Deck — Max 3 in. (76 mm) deep galv steel fluted roof deck.

A1. Steel Floor And Form Units\* — (Not Shown) Composite max 2.5 in. (64 mm) deep galv steel fluted units.

EPIC METALS CORP — Type "Toris C"

A2. Steel Floor And Form Units\* — (Not Shown) Composite max 2 in. (51 mm) deep galv steel fluted units.

NEW MILLENNIUM BUILDING SYSTEMS L L C — Versa-Dek®

A3. Steel Floor And Form Units\* (Configuration B) — Composite max 2 in. (51 mm) deep galv steel fluted units.

Verco Decking Inc — A Nucor Co — Type 2.0D FORMLOK

A4. Steel Floor And Form Units\* (Configuration B) — Composite max 2 in. (51 mm) deep galv steel fluted units.

VULCRAFT, DIV OF NUCOR CORP — Type 2.0D FORMLOK

B. Spray-Applied Fire Resistive Materials\* — (Not Shown) — Prior to or after the installation of the steel ceiling runners, Forming Material and Fill, Void or Cavity Material (Items 2A, 3A, 3B), the roof assembly shall be sprayed with the type and thickness of fire resistive material indicated in the individual P700 Series design.

GCP APPLIED TECHNOLOGIES INC — Type MK-6-HY

ISOLATEK INTERNATIONAL — Type 300

2. Wall Assembly — The 2 hr fire rated gypsum board /steel stud wall assembly shall be constructed of the materials and in the manner described in the individual U400 or V400 Series Wall and Partition Design in the UL Fire Resistance Directory and shall include the following construction features:

A. Steel Floor And Ceiling Runners — Floor and ceiling runners of wall assembly shall consist of min 25 ga galv steel channels sized to accommodate steel studs (Item 2C). Flange height of ceiling runner shall be min 1/4 in. (6 mm) greater than max extended joint width. Ceiling runner installed parallel to direction of fluted steel deck, centered beneath valley, and secured with steel masonry anchors, steel fasteners or welds spaced max 24 in. (610 mm) OC. before or after optional spray-applied fire resistive material is used. The use of welds to secure the ceiling runner may only be used prior to the installation of the optional spray-applied material.



A1. Light Gauge Framing\* — Slotted Ceiling Runner — As an alternate to the ceiling runner in Item 2A, slotted ceiling runner to consist of galv steel channel with slotted flanges sized to accommodate steel studs (Item 2C). Slotted ceiling runner installed parallel to direction of fluted steel deck, centered beneath valley, and secured with steel masonry anchors, steel fasteners or welds spaced max 24 in. (610 mm) OC. before or after optional spray-applied fire resistive material is used. The use of welds to secure the ceiling runner may only be used prior to the installation of the optional spray-applied material.

CALIFORNIA EXPANDED METAL PRODUCTS CO — CST  
CLARKDIETRICH BUILDING SYSTEMS — Type SLT, SLT-H  
MARINO/WARE, DIV OF WARE INDUSTRIES INC — Type SLT  
METAL-LITE INC — The System  
RAM SALES L L C — RAM Slotted Track  
SCAFCO STEEL STUD MANUFACTURING CO  
STEELER INC — Steeler Slotted Ceiling Runner  
TELLING INDUSTRIES L L C — True-Action Deflection Track

A2. Light Gauge Framing\* — Vertical Deflection Ceiling Runner — As an alternate to the ceiling runners in Items 2A and 2A1, vertical deflection ceiling runner to consist of galv steel channel with slotted vertical deflection clips mechanically fastened within runner. Slotted clips, provided with step bushings, for permanent fastening of steel studs. Flanges sized to accommodate steel studs (Item 2C). Vertical deflection ceiling runner installed parallel to direction of fluted steel deck, centered beneath deck, and secured with steel masonry anchors, steel fasteners or welds spaced max 24 in. (610 mm) OC. before or after optional spray-applied fire resistive material is used. The use of welds to secure the ceiling runner may only be used prior to the installation of the optional spray-applied material.

THE STEEL NETWORK INC — VertiTrack VTD250, VTD362, VTD400, VTD600 and VTD800

A3. Light Gauge Framing — Floor and Ceiling Runners — As an alternate to the ceiling and floor runners in Item 2A, 2A1, 2A2 and 2A3, floor and ceiling runners to consist of galv steel channel sized to accommodate the Light Gauge Framing\* Slotted Stud (Item 2C1) or Light Gauge Framing\* Slider C-Clip System (Item 2C2). Floor and ceiling runners to be provided with min 1-1/4 in. (32 mm) and 3 in. (76 mm) flanges, respectively. Ceiling runner installed parallel to direction of fluted steel deck, centered beneath deck, and secured with steel masonry anchors, steel fasteners or welds spaced max 24 in. (610 mm) OC. before or after optional spray-applied fire resistive material is used. The use of welds to secure the ceiling runner may only be used prior to the installation of the optional spray-applied material.

STEELER INC — Floor and Ceiling Runners

A4. Light Gauge Framing\* — Notched Ceiling Runner — As an alternate to the ceiling runners in Items 2A through 2A4, notched ceiling runners to consist of C-shaped galv steel channel with notched return flanges sized to accommodate steel studs (Item 2C). Notched ceiling runner installed parallel to direction of fluted steel deck, centered beneath valley, and secured with steel masonry anchors, steel fasteners or welds spaced max 24 in. (610 mm) OC. before or after optional spray-applied fire resistive material is used. The use of welds to secure the ceiling runner may only be used prior to the installation of the optional spray-applied material.

OLMAR SUPPLY INC — Type SCR

B. Steel Attachment Clips — (Optional — Not Shown) — When spray applied fireproofing is used ceiling runner may be secured to deck with Z-shaped clips formed from min 1 in. (25 mm) long strips of min 20 ga galv steel. Length of clips should not exceed the width (thickness) of the wall. Clips to be sized to extend through the thickness of the spray-applied fire-resistive material on the bottom of the steel deck with 1-1/2 or 2 in. (38 or 51 mm) long upper and lower legs. Legs of clips fastened perpendicular to valleys of steel deck (prior to application of spray-applied fire-resistive materials) and top of ceiling runner with steel fasteners or welds. Clips spaced max 24 in. (610 mm) OC.

C. Studs — Steel studs to be min 2-1/2 in. (64 mm) wide. When Epic Metals composite floor or roof deck (Item 1A1) is used, studs to be min 3-5/8 in. (92 mm) wide. Studs cut 1/2 to 3/4 in. (13 to 19 mm) less in length than assembly height with bottom nesting in and resting on floor runner and with top nesting in ceiling runner without attachment. When slotted ceiling runner (Item 2A1) is used, steel studs secured to slotted ceiling runner with No. 8 by 1/2 in. (13 mm) long wafer head steel screws at midheight of slot on each side of wall. Stud spacing not to exceed 24 in. (610 mm) OC. When vertical deflection ceiling runner (Item 2A2) is used, steel studs secured to slotted vertical deflection clips, through the bushings, with steel screws at midheight of each slot. Stud spacing not to exceed 24 in. (610 mm) OC.



C1. Light Gauge Framing\* — Slotted Studs — Slotted steel stud to be used in conjunction with Light Gauge Framing\* — Floor and Ceiling Runners (Item 2A4). Slotted steel studs to be min 2-1/2 in. (64 mm) wide. Slotted steel studs cut 1 in. less in length than assembly height with bottom nesting in and secured to both ceiling and floor runners. Ceiling runner secured to preformed slot within steel stud by means of No. 10 by 3/4 in. (19 mm) long low profile head steel screw. Floor runner attached to bottom of steel stud by means of No. 8 by 1/2 in. (13 mm) long pan head steel screw. Slotted steel stud spacing not to exceed 24 in. (610 mm) OC.

STEELER INC — Slotted Stud

C2. Light Gauge Framing\* — Slider C-Clip System — As an alternate to the Light Gauge Framing\* — Slotted Steel Studs (Item 2C1), a Slider C-Clip System consisting of a C shaped steel clip with a slotted opening and a steel stud to be used in conjunction with Light Gauge Framing — Floor and Ceiling Runners (Item 2A4). Steel clips and studs to be min 2-1/2 in. (64 mm) wide. Steel clip inserted into inside flange of steel stud without attachment. Total length of steel stud cut 1 in. (25 mm) less than assembly height with bottom of steel stud nesting in and secured to floor runner. Floor runner attached to bottom of steel stud by means of No. 8 by 1/2 in. (13 mm) long pan head steel screw. Ceiling runner secured to steel C-Clip by means of No. 10 by 3/4 in. (19 mm) long pan head steel screw located 3/8 in. (10 mm) below top of ceiling runner. Top row of gypsum board screws shall be centered within the preformed slot of the C-Clip. Steel stud and steel clips spacing not to exceed 24 in. (610 mm) OC.

STEELER INC — Slider C Clip System

D. Gypsum Board\* — Gypsum board installed to a min total thickness of 5/8 in. (16 mm) and 1-1/4 in. (32 mm) on each side of wall for 1 and 2 Hr rated assemblies respectively. Wall to be constructed as specified in the individual Wall and Partition Design in the UL Fire Resistance Directory, except that a nom 1 in. (25 mm) gap shall be maintained between the top of the gypsum board and the bottom of the steel floor units and the top row of screws shall be installed into the studs 1-1/2 (38 mm) to 2 in. (51 mm) below the bottom of the ceiling runner. The hourly rating of the joint system is equal to the hourly fire rating of the wall.

3. Joint System — Max separation between bottom of floor and top of wall at time of installation of joint system is 1 in. (25 mm). The joint system is designed to accommodate a max 50 percent compression or extension from its installed width. The joint system consists of forming material and a fill material, as follows:

A. Forming Material\* — Nom 5/8 in. (16 mm) and 1-1/4 in. (32 mm) wide strips of min 4 pcf (64 kg/m<sup>3</sup>) mineral wool batt insulation for 1 and 2 hr rated assemblies respectively, cut to thickness, compressed 50 percent in thickness and firmly packed into the gap between the top of the gypsum board and bottom of the steel floor units on both sides of the wall.

INDUSTRIAL INSULATION GROUP L L C — MinWool-1200 Safing

ROCK WOOL MANUFACTURING CO — Delta- Board

ROCKWOOL — SAFE

THERMAFIBER/OWENS CORNING — Type SAF

A1. Forming Material\* — Strips — (Optional) — Nom 5/8 in. (16 mm) and 1-1/4 in. (32 mm) wide precut mineral wool strips for 1 and 2 hr rated assemblies respectively. The strips are compressed 50 percent in thickness and firmly packed into the gap between the top of the gypsum board and bottom of the steel floor units on both sides of the wall.

HILTI CONSTRUCTION CHEMICALS, DIV OF HILTI INC — CP 767 Speed Strips

B. Fill, Void or Cavity Material\* — Min 1/16 in. (1.6 mm) dry thickness (min 1/8 in. or 3.2 mm wet thickness) of fill material sprayed or troweled on each side of the wall to completely cover mineral wool forming material and to overlap a min of 1/2 in. (13 mm) onto gypsum board and steel deck on both sides of wall. When spray-applied fire resistive material is applied to the steel floor and form units, the fill material is to overlap the gypsum board a min of 1/2 in. (13 mm) and the spray-applied fire resistive material a min of 2 in. (51 mm) on both sides of wall. When spray-applied fire resistive materials are used, the joint spray shall overlap the wall a min 1/2 in. (13 mm) and overlap the spray-applied fire resistive material a min of 2 in. (51 mm) on both sides of the wall.

HILTI CONSTRUCTION CHEMICALS, DIV OF HILTI INC — CFS-SP WB Firestop Joint Spray

\* Indicates such products shall bear the UL or cUL Certification Mark for jurisdictions employing the UL or cUL Certification (such as Canada), respectively.

