



Classified by  
Underwriters Laboratories, Inc.  
to CAN/ULC-S115

## System No. HW-D-0087



HWD 0087

F Ratings — 1 and 2 Hr (See Items 2 and 3B)

FT Ratings — 1 and 2 Hr (See Items 2 and 3B)

FH Ratings — 1 and 2 Hr (See Items 2 and 3B)

FTH Ratings — 1 and 2 Hr (See Items 2 and 3B)

Nominal Joint Width — 2 In.

L Rating At Ambient — Less Than 1 CFM/Lin Ft

L Rating At 400°F — Less Than 1 CFM/Lin Ft

Class II And III Movement Capabilities — 20% Compression Or Extension, or  
Class II Movement Capabilities — 20% Compression and 12.5% Extension (See Item 1C)

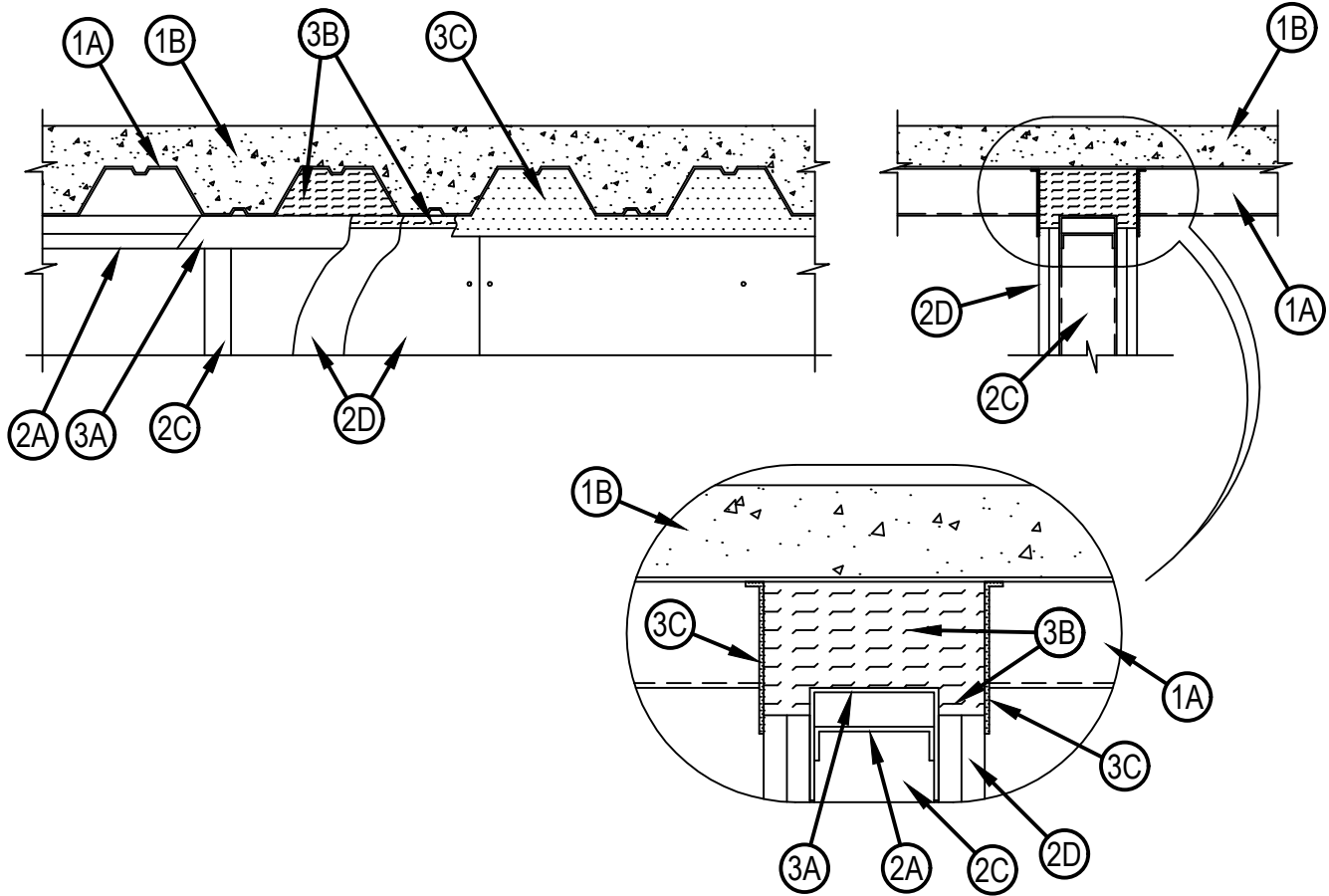

# System No. HW-D-0087



HWD 0087

1. Floor Assembly — The fire-rated fluted steel deck/concrete floor assembly shall be constructed of the materials and in the manner described in the individual D700 or D900 Floor-Ceiling Design in the UL Fire Resistance Directory and shall include the following construction features:
  - A. Steel Floor and Form Units\* — Max 3 in. (76 mm) deep galv steel fluted floor units.
  - B. Concrete — Min 2-1/2 in. (64 mm) thick reinforced concrete, as measured from the top plane of the floor units.
  - C. Spray—Applied Fire Resistive Materials\* — Prior to or after the installation of the deflection channel, Forming Material and Fill, Void or Cavity Material (Items 3A, 3B, 3C) the steel floor units may be sprayed with a min 5/16 in. (8 mm) to max 1-3/4 in. (44 mm) thickness of fire resistive material.
    - GCP APPLIED TECHNOLOGIES INC — Type MK-6-HY
    - ISOLATEK INTERNATIONAL — Type 300
    - When Type 300 spray is used, the movement cycling for the joint is Class II Movement Capabilities with 20% Compression and 12.5% Extension.
- 1A. Roof Assembly — (Not Shown) — As an alternate to the floor assembly, a fire rated fluted steel deck roof assembly may be used. The roof assembly shall be constructed of the materials and in the manner described in the individual P900 Series Roof-Ceiling Design in the UL Fire Resistance Directory. The hourly rating of the roof assembly shall be equal to or greater than the hourly rating of the wall assembly. The roof assembly shall include the following construction features:
  - A. Steel Roof Deck — Max 3 in. (76 mm) deep galv steel fluted roof deck.
  - B. Roof Insulation — Min 2-1/4 in. (57 mm) thick poured insulating concrete, as measured from the top plane of the floor units.
- 1B. Roof Assembly — As an alternate to Items 1 and 1A, a fire rated protected fluted steel deck roof assembly may be used. The roof assembly shall be constructed of the materials and in the manner described in the individual P700 Series Roof-Ceiling Design in the UL Fire Resistance Directory. The hourly rating of the roof assembly shall be equal to or greater than the hourly rating of the wall assembly. The roof assembly shall include the following construction features:
  - A. Steel Roof Deck — Max 3 in. (76 mm) deep galv steel fluted roof deck.
  - B. Spray—Applied Fire Resistive Materials\* — (Not Shown)—Prior to or after the installation of the steel ceiling runners, Forming Material and Fill, Void or Cavity Material (Items 2A, 3A, 3B), the roof assembly shall be sprayed with the type and thickness of fire resistive material indicated in the individual P700 Series design.
2. Wall Assembly — The 1 or 2 hr fire rated gypsum board/steel stud wall assembly shall be constructed of the materials and in the manner described in the individual U400 or V400 Series Wall and Partition Design in the UL Fire Resistance Directory and shall include the following construction features:
  - A. Steel Floor and Ceiling Runners — Floor and ceiling runners of wall assembly shall consist of galv steel channels sized to accommodate steel studs (Item 2C). Ceiling runner to be provided with 1 in. (25 mm) flanges. Ceiling runner installed within the U-shaped deflection channel (Item 3A) with a 1-1/2 in. (38 mm) gap maintained between the top of ceiling runner and top of deflection plate.
  - A1. Light Gauge Framing\*-Slotted Ceiling Runner — (For use in applications where the nominal joint width does not exceed 1-1/2 in. or 38 mm) - As an alternate to the ceiling runner in Item 2A, slotted ceiling runner to consist of galv steel channel with slotted flanges sized to accommodate steel studs (Item 2C). Slotted ceiling runner installed perpendicular to direction of fluted steel deck before or after fireproofing and secured to valleys with steel masonry anchors, steel fasteners or welds spaced max 24 in. (610 mm) OC. The use of welds to secure the ceiling runner may only be used prior to the installation of the optional spray-applied material. When slotted ceiling runner is used, deflection channel (Item 3A) shall not be used. When optional spray-applied material is used on the steel deck, slotted ceiling runner secured through spray-applied material to each valley of the steel deck with min 3/16 in. (5 mm) diam steel fasteners, steel masonry anchors spaced max 24 in. (610 mm) OC.
    - BRADY CONSTRUCTION INNOVATIONS INC, DBA SLIPTRACK SYSTEMS — SLP-TRK
    - CEMCO, LLC — CST
    - CLARKDIETRICH BUILDING SYSTEMS — Type SLT, SLT-H
    - SCAFCO STEEL STUD MANUFACTURING CO
    - TELLING INDUSTRIES L L C — True-Action Deflection Track



Hilti Firestop Systems

Reproduced by HILTI, Inc. Courtesy of  
Underwriters Laboratories, Inc.  
June 22, 2023

A2. Light Gauge Framing\* - Vertical Deflection Ceiling Runner — (For use in applications where the nominal joint width does not exceed 1 in. or 25 mm) - As an alternate to the ceiling runners in Items 2A and 2A1, vertical deflection ceiling runner to consist of galv steel channel with slotted vertical deflection clips mechanically fastened within runner. Slotted clips provided with step bushings for permanent fastening of steel studs. Flanges sized to accommodate steel studs (Item 2C). Vertical deflection ceiling runner installed perpendicular to direction of fluted steel deck and secured before or after spray-applied materials to valleys with steel masonry anchors, steel fasteners or welds spaced max 24 in. (610 mm) OC. The use of welds to secure the ceiling runner may only be used prior to the installation of the optional spray-applied material. When vertical deflection ceiling runner is used, deflection channel (Item 3A) shall not be used. When optional spray-applied material is used on the steel deck, vertical deflection ceiling runner secured through spray-applied material to each valley of the steel deck with min 3/16 in. (5 mm) diam steel fasteners or steel masonry anchors spaced max 24 in. (610 mm) OC.

THE STEEL NETWORK INC — VertiTrack VTD250, VTD362, VTD400, VTD600 and VTD800

A3. Light Gauge Framing\* - Notched Ceiling Runner — As an alternate to the ceiling runners in Items 2A through 2A3, notched ceiling runners to consist of C-shaped galv steel channel with notched return flanges sized to accommodate steel studs (Item 2C). Notched ceiling runner installed perpendicular to direction of fluted steel deck and secured before or after spray-applied materials to valleys with steel masonry anchors, steel fasteners or welds spaced max 24 in. (610 mm) OC. The use of welds to secure the ceiling runner may only be used prior to the installation of the optional spray-applied material. When notched ceiling runner is used, deflection channel (Item 3A) shall not be used. When optional spray-applied material is used on the steel deck, notched ceiling runner secured through spray-applied material to each valley of steel deck with min 3/16 in. (5 mm) diam steel fasteners spaced max 24 in. (610 mm) OC.

OLMAR SUPPLY INC — Type SCR

B. Steel Attachment Clips — (Optional - Not Shown) - When spray applied fireproofing is used ceiling runner may be secured to deck with Z-shaped clips formed from min. 1 in. (25 mm) long strips of min 20 ga galv steel. Length of clips should not exceed the width (thickness) of the wall. Clips to be sized to extend through the thickness of the spray-applied fire-resistive material on the bottom of the steel deck with 1-1/2 or 2 in. (38 or 51 mm) long upper and lower legs. Legs of clips fastened to valleys of steel deck (prior to application of spray-applied fire-resistive materials) and top of ceiling runner with steel fasteners or welds. Clips spaced max 24 in. (610 mm) OC.

C. Studs — Steel studs to be min 2-1/2 in. (64 mm) wide. Studs cut 1/2 to 3/4 in. (13 to 19 mm) less in length than assembly height with bottom nesting in and resting on floor runner and with top nesting in ceiling runner without attachment. When slotted ceiling runner (Item 2A1) is used, steel studs secured to slotted ceiling runner with No. 8 by 1/2 in. (13 mm) long wafer head steel screws at midheight of slot on each side of wall. When vertical deflection ceiling runner (Item 2A2) is used, steel studs secured to slotted vertical deflection clips, through the bushings, with steel screws at midheight of each slot. Stud spacing not to exceed 24 in. (610 mm) OC.

D. Gypsum Board\* — Gypsum board installed to a min total thickness of 5/8 in. (16 mm) or 1-1/4 in. (32 mm) on each side of wall for 1 and 2 hr rated assemblies, respectively. Wall to be constructed as specified in the individual Wall and Partition Design in the UL Fire Resistance Directory, except that a nom 2 in. (51 mm) gap shall be maintained between the top of the gypsum board and the bottom of the steel deck and the top row of screws shall be installed into the studs 4 to 4-1/2 in. (102 to 114 mm) below the lower surface of the floor or roof. The hourly rating of the joint system is dependent on the hourly rating of the wall.

3. Joint System — Max separation between bottom of floor and top of wall at time of installation of joint system is 2 in. (51 mm). The joint system is designed to accommodate a max 20 or 12.5 percent (see Item 1C) compression or extension from its installed width. The joint system consists of a deflection channel, forming material and a fill material as follows:

A. Deflection Channel — A nom 3-5/8 in. (92 mm) wide by 3 in. (76 mm) deep min No. 22 gauge steel U-shaped channel. Deflection channel installed perpendicular to direction of fluted steel deck and secured to valleys with masonry anchors, steel fasteners or welds spaced max 24 in. (610 mm) OC before or after optional spray-applied fire resistive material is used. The ceiling runner (Item 2A) is installed within the deflection channel to maintain a 1-1/2 in. (38 mm) gap between the top of the ceiling runner and the top of the deflection channel. The ceiling runner is not fastened to the deflection channel.



B. Forming Material\* — Nom 4 pcf (64 kg/m<sup>3</sup>) density mineral wool batt insulation cut approx 25 percent wider than the flutes and with a length approx equal to the overall thickness of the wall. Multiple pieces stacked on top of each other, as needed, and then compressed 50 percent in thickness and inserted into the flutes of the steel deck above the top of the ceiling runner. The mineral wool batt insulation is to project beyond each side of the ceiling runner, flush with wall surfaces. Additional 5/8 in. (16 mm) and 1-1/4 in. (32 mm) wide strips for 1 and 2 hr rated assemblies, respectively, of nom 4 pcf (64 kg/m<sup>3</sup>) mineral wool batt insulation are to be cut to fill the gap between the top of the gypsum board and bottom of the steel deck. The strips of mineral wool are compressed 50 percent and tightly packed, cut edge first, into the gap between the top of the gypsum board and bottom of the steel deck on both sides of the wall.

ROCK WOOL MANUFACTURING CO — Delta Board

ROCKWOOL — SAFE

THERMAFIBER INC — Type SAF

B1. Forming Material\*—Plugs (For use with 3-1/2 in. or 89 mm deep studs or larger) — (Optional-Not Shown) - Preformed mineral wool plugs, formed to the shape of the fluted floor units, friction fit to completely fill the flutes above the ceiling runner. The plugs shall project beyond each side of the ceiling runner, flush with wall surfaces. Additional forming material, described in Item 3B, to be used in conjunction with the plugs to fill the gap between the top of gypsum board and the bottom of plug .

HILTI CONSTRUCTION CHEMICALS, DIV OF HILTI INC — CP777 Speed Plugs

B2. Forming Material\* - Strips — (Optional) - Nom 5/8 in. (16 mm) and 1-1/4 in. (32 mm) wide by 4 in. (102 mm) thick precut mineral wool strips for 1 and 2 hr rated assemblies, respectively. The strips are compressed 50 percent in thickness and firmly packed into the gap between the top of the gypsum board and bottom of the steel floor units on both sides of the wall.

HILTI CONSTRUCTION CHEMICALS, DIV OF HILTI INC — CP 767 Speed Strips

C. Fill, Void or Cavity Material\* — Min 1/16 in. (1.6 mm) dry thickness (min 1/8 in. or 3.2 mm wet thickness) of fill material sprayed or troweled on each side of the wall to completely cover mineral wool forming material and to overlap a min of 1/2 in. (13 mm) onto gypsum board and steel deck on both sides of wall. When spray-applied fire resistive material is applied to the steel deck, the fill material is to overlap the gypsum board a min of 1/2 in. (13 mm) and the spray-applied fire resistive material a min of 2 in. (51 mm) on both sides of wall. When spray-applied fire resistive materials are used, the CP672 firestop spray shall overlap the wall a min 1/2 in. (13 mm) and overlap the spray-applied fire resistive material a min of 2 in. (51 mm) on both sides of the wall.

HILTI CONSTRUCTION CHEMICALS, DIV OF HILTI INC — CP672 Firestop Spray or CFS-SP WB Firestop Joint Spray

\* Indicates such products shall bear the UL or cUL Certification Mark for jurisdictions employing the UL or cUL Certification (such as Canada), respectively.

