

FASTEN DECK WITH THE PATTERN AS SPECIFIED IN THE TABLE BELOW USING HILTI S-MD 12-24x1-5/8 HWH5 FASTENERS FOR BASE STEEL THICKNESS 16 GA. $t_f \leq 1/4"$.

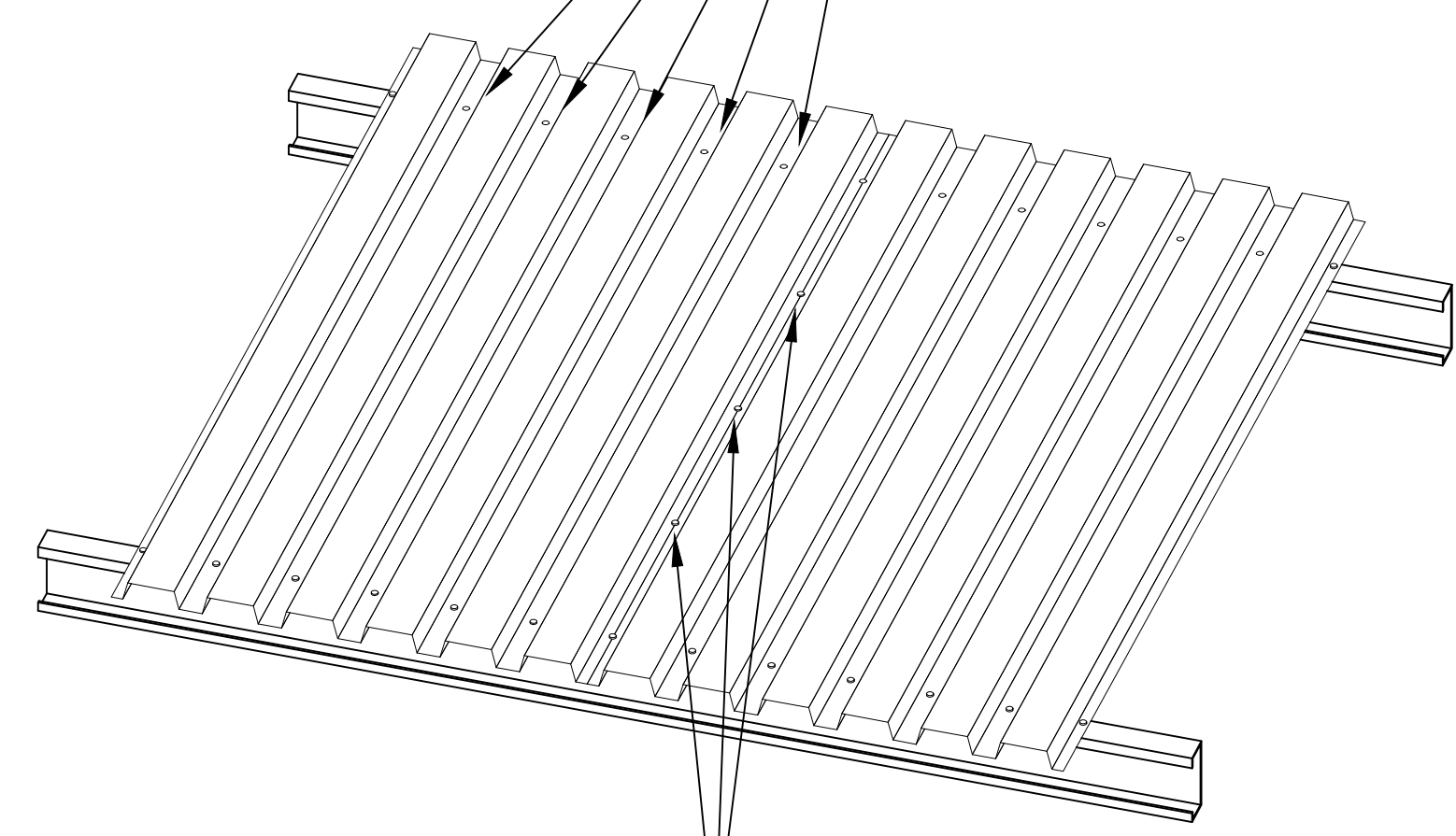

FASTEN SIDELAP USING HILTI S-SLC 01 M HWH (18 GA. TO 26 GA.) OR HILTI S-SLC 02 M HWH (16 GA. TO 22 GA.) FASTENERS AT XX" ON CENTER.

FASTEN SIDELAP USING HILTI S-SLC 01 M HWH (18 GA. TO 26 GA.) OR HILTI S-SLC 02 M HWH (16 GA. TO 22 GA.) FASTENERS AT XX" ON CENTER.

FASTEN DECK WITH THE PATTERN AS SPECIFIED IN THE TABLE BELOW USING HILTI X-HSN 24 FASTENERS FOR BASE STEEL THICKNESS 1/8" $t_f \leq 3/8"$.

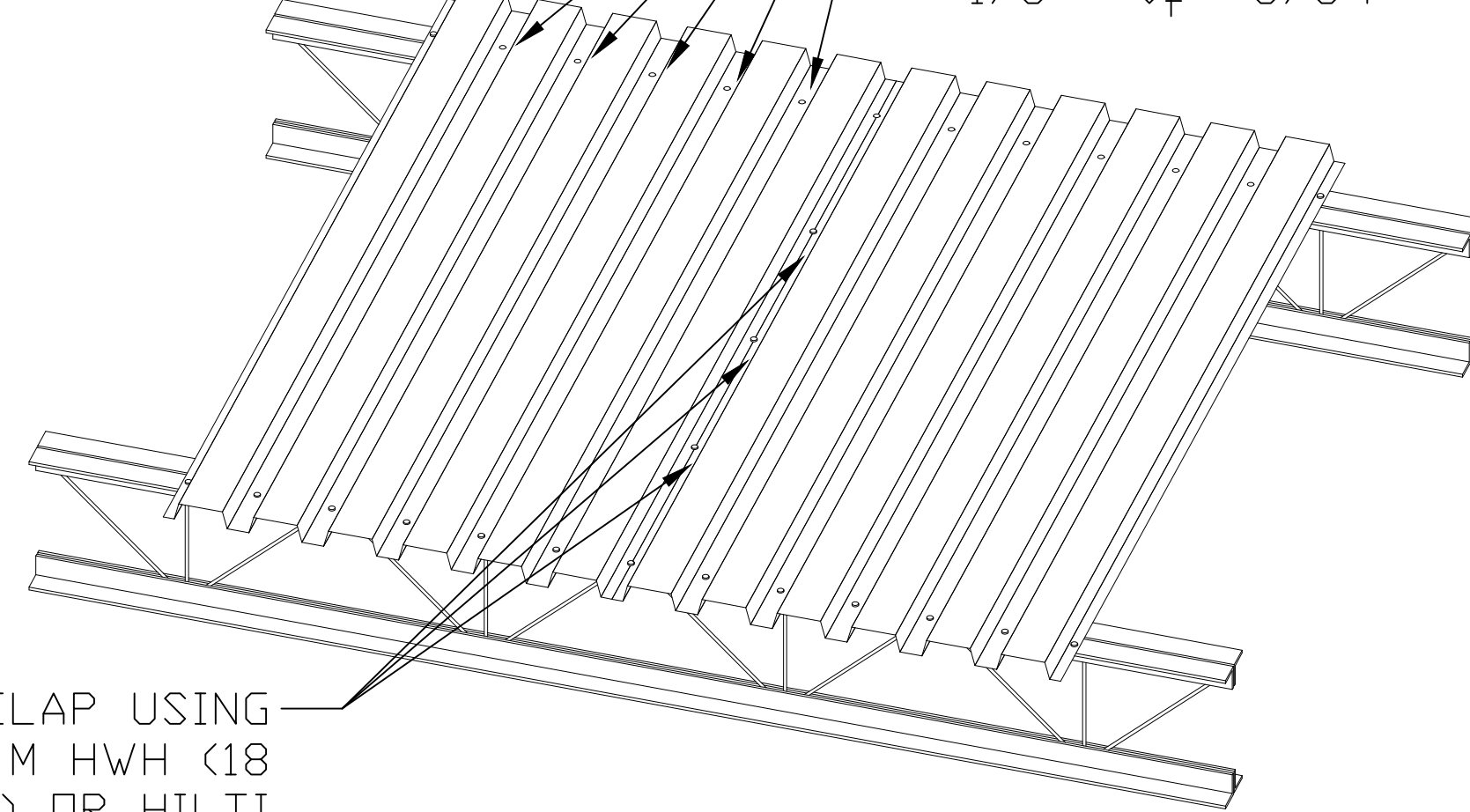

FASTEN DECK WITH THE PATTERN AS SPECIFIED IN THE TABLE BELOW USING HILTI X-HSN 24 FASTENERS FOR BASE STEEL THICKNESS 1/8" $t_f \leq 3/8"$. USE HILTI X-ENP 19 L15 FASTENERS FOR BASE STEEL THICKNESS $t_f \geq 1/4"$.

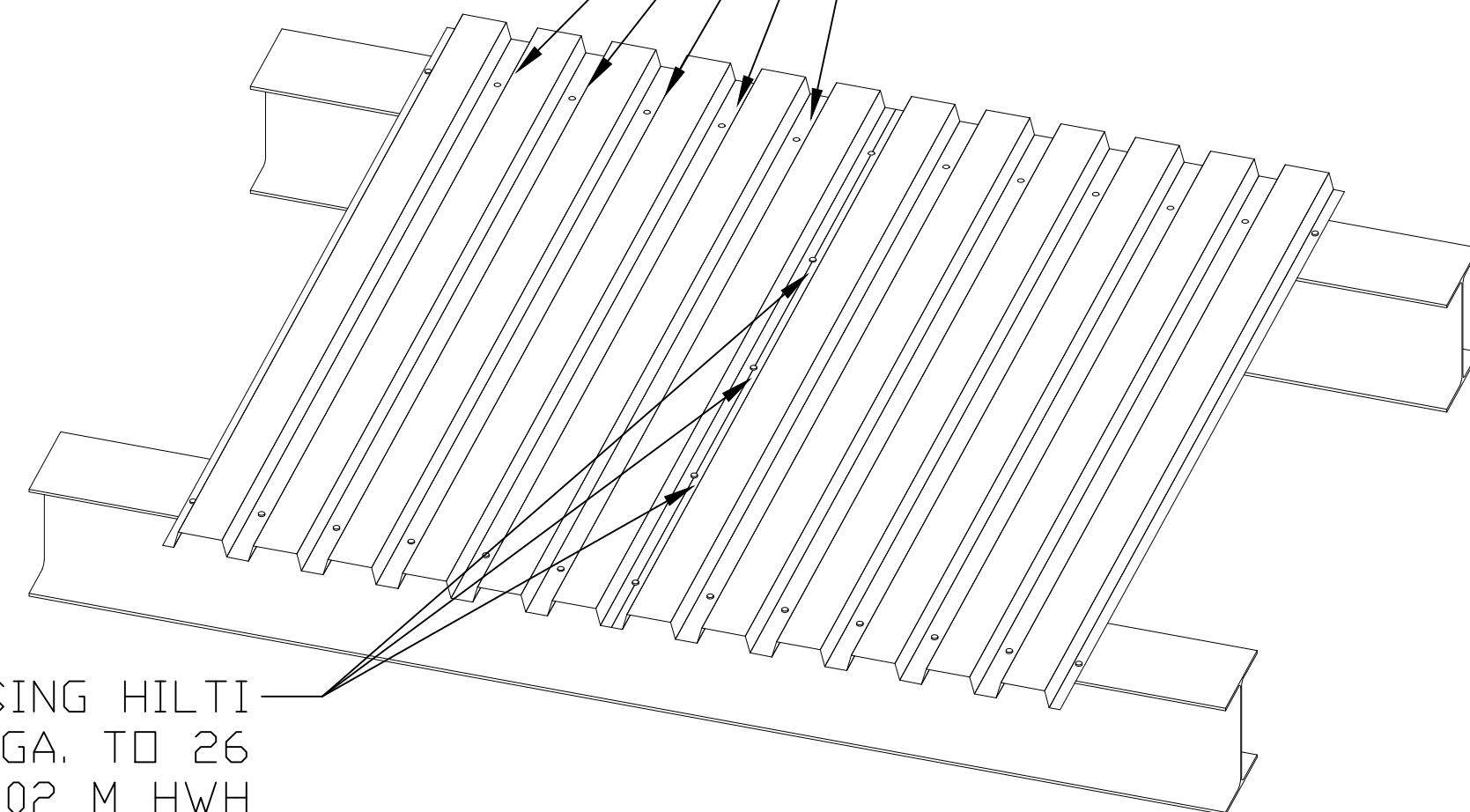

FASTEN SIDELAP USING HILTI S-SLC 01 M HWH (18 GA. TO 26 GA.) OR HILTI S-SLC 02 M HWH (16 GA. TO 22 GA.) FASTENERS AT XX" ON CENTER.

SEALING CAPS

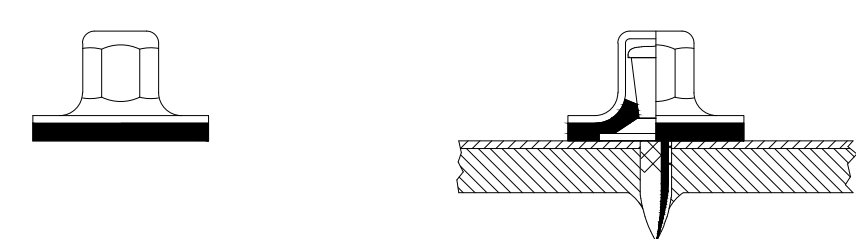

HILTI SDK2 SAE 316 SEALING CAP (FOR USE WITH X-ENP-19 FASTENER ON EXPOSED STEEL DECK APPLICATIONS)

- Notes Steel Joists
- Contractor shall provide means to ensure adequate distribution of concentrated loads so that load-bearing capacity of any joist is not exceeded. Joist ends shall be attached to supports in accordance with CSA S16-14 after having been straightened and plumbed and all bridging is installed and connected.
 - All welding of joist ends and bridging shall conform to the latest edition of CSA W59.
 - Ends of bottom chord support bearing joists shall be laterally restrained in accordance with CSA S16-14
 - Roof joists shall be designed for net uplift pressure of (PROVIDE PSF DESIGN REQUIREMENTS IF APPLICABLE). Steel Deck
 - Steel deck shall conform to ASTM A653/A653M and CSSBI B13-06 or SDI Design Manual for Composite Decks, Form Decks and Roof Decks. Steel deck shall be recognized under the latest version of ICC-ES AC43 Acceptance Criteria for Steel Deck, Roof and Floor Systems.
 - Shop drawings indicating steel deck layout, fastening method and pattern shall be submitted to the Structural Engineer of Record prior to steel deck installation.
 - Refer to Architectural and Mechanical drawings for size and location of all roof openings, roof drain details, skylight and roof hatch details.
 - Roof elevations shown on Drawings are measured from finished floor slab below to top of joist.
 - Contractor shall take all necessary precautions to ensure steel deck is not damaged prior to installation during storage, handling and erection. Damaged steel deck shall be replaced.
 - Steel deck shall be stored off the ground with one end elevated to provide drainage and should be protected from the elements with a waterproof covering ventilated to prevent condensation.
 - Steel deck panels shall be placed straight and true with a maximum 1/4-inch horizontal misalignment in 100 feet length. Steel deck shall be marked over joist chords prior to fastening to prevent weld burn through or mechanical fastener punch through.
 - Steel deck shall span a minimum of 3 spans typical unless noted otherwise.
 - Endlaps of steel deck shall overlap adjacent sheets a minimum of 2 inches unless noted otherwise.
 - Steel deck shall be installed in accordance with FM, UL and CSSBI-10M-13 standards (INSERT APPROPRIATE STANDARD DESIGNATIONS).
 - Accessories, ridge and valley plates, sump pans and closure pieces shall be of the same material and coating as the adjacent steel deck.
 - Framing around typical openings shall be in accordance with standard practice details provided in CSSBI-10M-13.
 - Contractor shall verify the weights and locations of all mechanical units shown on the Drawings, and report findings and any deviations to the Structural Engineer of Record.
 - Hangers or accessory point loads shall not be supported from steel deck without approval from the Structural Engineer of Record.
 - Where shown on Drawings, deck accessories shall be installed according to manufacturer's recommendations. Mechanical Fasteners
 - Install powder-actuated and screw fasteners according to the manufacturer's recommendations.
 - Powder-actuated fasteners shall be manufactured from AISI 1070 modified steel, austempered to a Rockwell C Hardness of 52 - 58. Fasteners shall have minimum tensile and shear strengths of 285 ksi and 182 ksi respectively. Screw frame fasteners shall be manufactured from Grade 1010 to 1022 or 10B08 to 10B22 carbon steel per ASTM A510.
 - Powder-actuated fasteners shall have full-tip knurling and minimum 12-mm diameter steel washers. Screw frame fasteners shall have wave form cutting edge self-drilling tips and Hex Washer Heads.
 - Powder-actuated and screw frame fasteners shall be zinc plated to a thickness of 5 µm in accordance with ASTM B633, Sc. 1, Type III.
 - Powder-actuated and screw frame fasteners shall be CSSBI or SDI listed for diaphragm design and wind uplift, UL and FM listed for fire resistance and wind uplift. Powder actuated fasteners shall be recognized by ICC-ES for diaphragm shear strength in accordance with the latest version of ICC-ES AC43. Sidelap connectors shall be FM listed for wind uplift and recognized by ICC-ES for diaphragm shear strength and stiffness in accordance with the latest version of ICC-ES AC 43.
 - Approved frame fasteners shall be Hilti X-HSN 24 or X-ENP-19 powder-actuated fasteners or Hilti S-MD 12-24x1-5/8 HWH5 screw fasteners at locations and spacing shown on drawings.
 - Approved sidelap connectors shall be Hilti S-SLC 01 M HWH or S-SLC 02 M HWH sidelap connectors or button punches at locations and spacing shown on drawings.

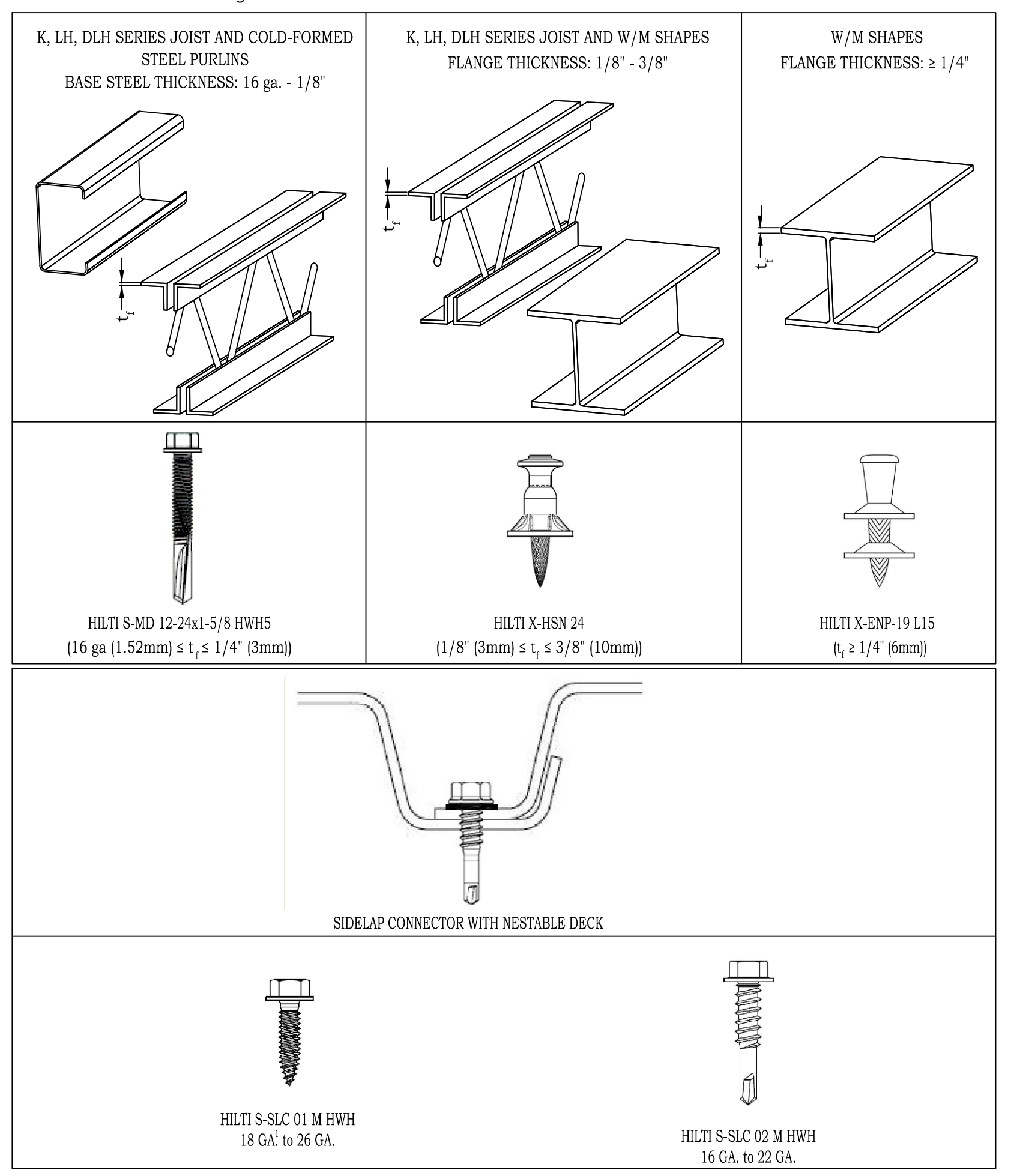

Zone	Deck Type	Deck Gauge	Deck Sidelap Configuration	Fastener Type	Fastener Pattern	Sidelap Fastener	Joist/Beam Spacing (ft)	Sidelap Pattern	Design Diaphragm Shear Capacity (plf)
A	1 1/2" (B) x 36"	18	Nestable	X-ENP-19 L15	36/5	S-SLC 02 M HWH	5	6" O.C.	1000
B	1 1/2" (B) x 36"	20	Nestable	X-HSN-24	36/7	S-SLC 02 M HWH	5	12" O.C.	893
C	3: (N) X 24"	22	Nestable	X-HSN-24	24/6	S-SLC 02 M HWH	5	6" O.C.	768
D	3: (N) X 24"	16	Nestable	X-ENP-19 L15	24/4	S-SLC 02 M HWH	5	12" O.C.	906
E	1 1/2" (B) x 36"	22	Nestable	S-MD 12-24X1-5/8" M HWH5 RT	36/7	S-SLC 02 M HWH	5	6" O.C.	638
...									
...									

SHEET-TITLE-LINE-01
SHEET-TITLE-LINE-02
 SHEET-TITLE-LINE-03
 SHEET-TITLE-LINE-04

JOB-NUMBER
 DRAWN:
 DRAFTER
 CHECKED:
 CHECKER
 ISSUE DATE:
 DATE
 REVISIONS:
 REVISION-LINE-01
 REVISION-LINE-02
 REVISION-LINE-03
 REVISION-LINE-04
 SHEET NAME:
 SHEET-NAME-LINE-01
 SHEET-NAME-LINE-02
 SHEET-NAME-LINE-03
 SHEET-NAME-LINE-04

SHEET NUMBER:
01
 SHEET-COUNT

1 USE DF S-SLC 01 M HWH WITH 18 GA. STEEL DECK. IS RECOMMENDED ONLY FOR STANDARD TENSILE STRENGTH (<45 KSI & F_u < 65 KSI) STEEL DECK. FOR HIGH TENSILE STRENGTH (F_u > 65 KSI) 18 GA. STEEL DECK, USE S-SLC 02 M HWH.

POWDER ACTUATED FASTENER SYMBOLS/PATTERNS

SIDELAP SYMBOLS

HILTI S-SLC 01 M HWH

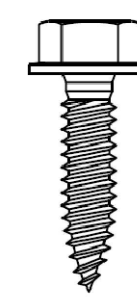

SCREW FASTENED SIDELAP

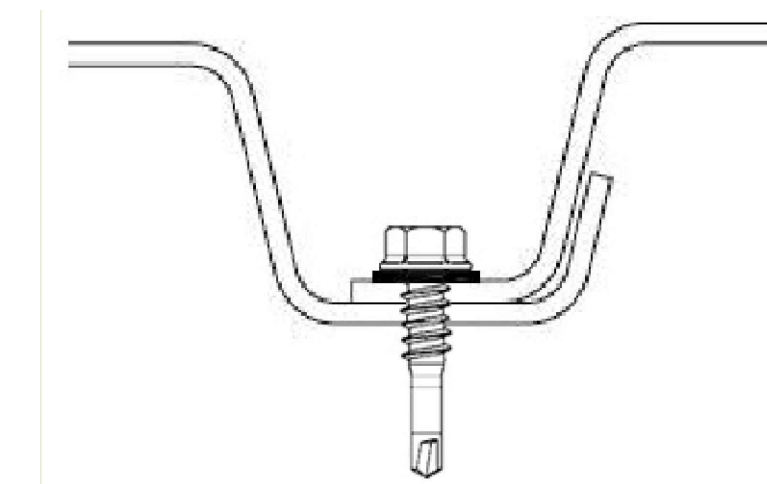

NESTABLE

HILTI S-SLC 02 M HWH

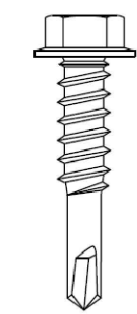

BUTTON PUNCHED SIDELAP

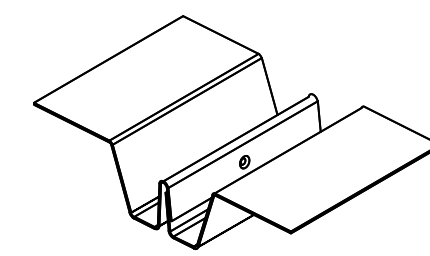

INTERLOCKING

BUTTON PUNCH TEXT

BUTTON PUNCH SIDELAPS @ _____ IN. C-C

SEALING CAPS

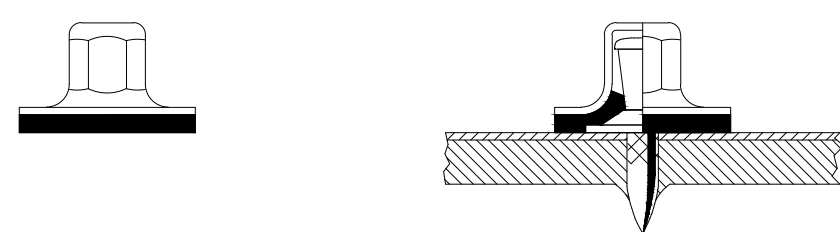

HILTI SDK2 SAE 316 SEALING CAP
(FOR USE WITH X-ENP-19 FASTENER ON
EXPOSED STEEL DECK APPLICATIONS)

NESTABLE DECK

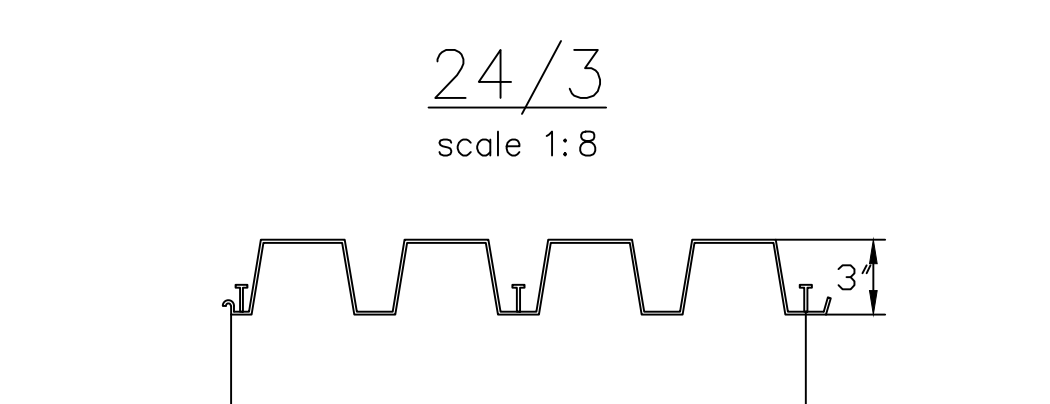
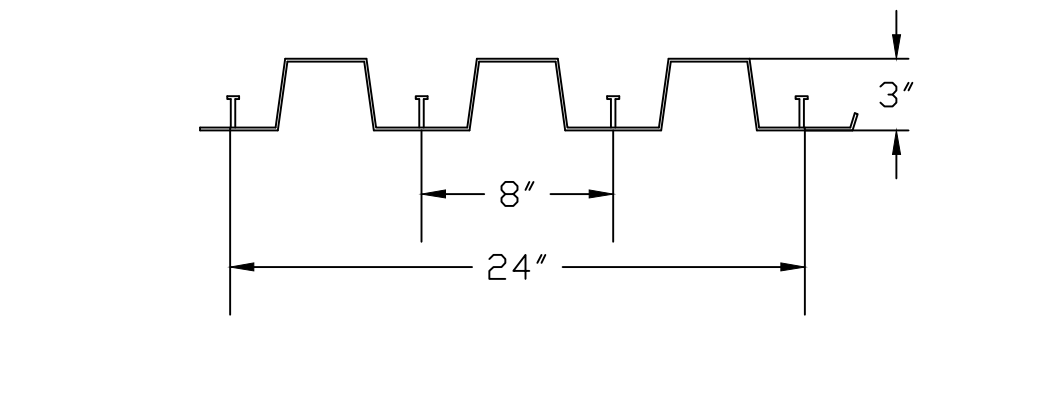
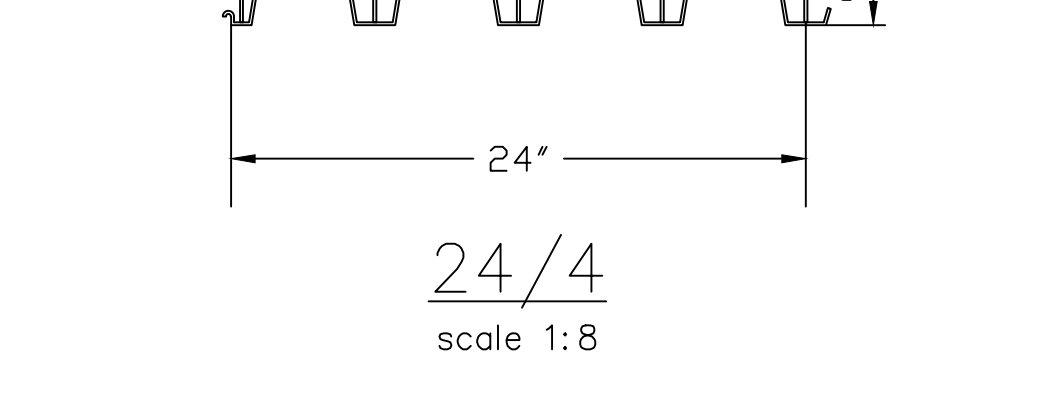
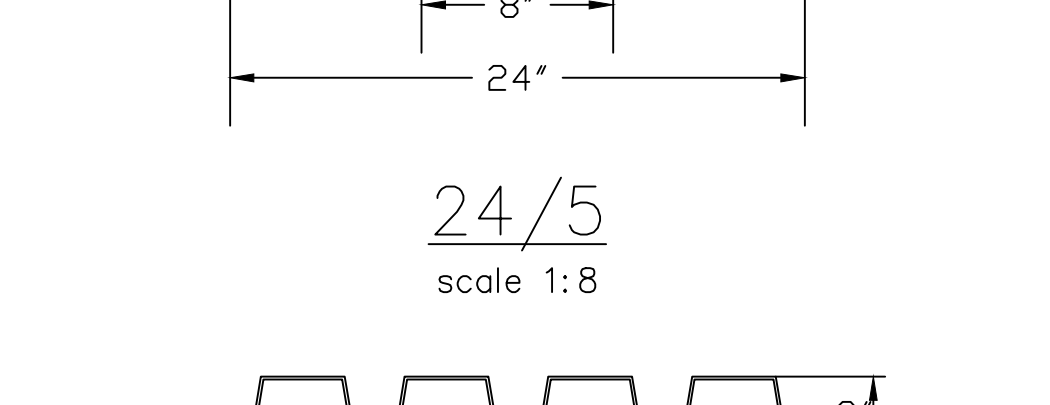
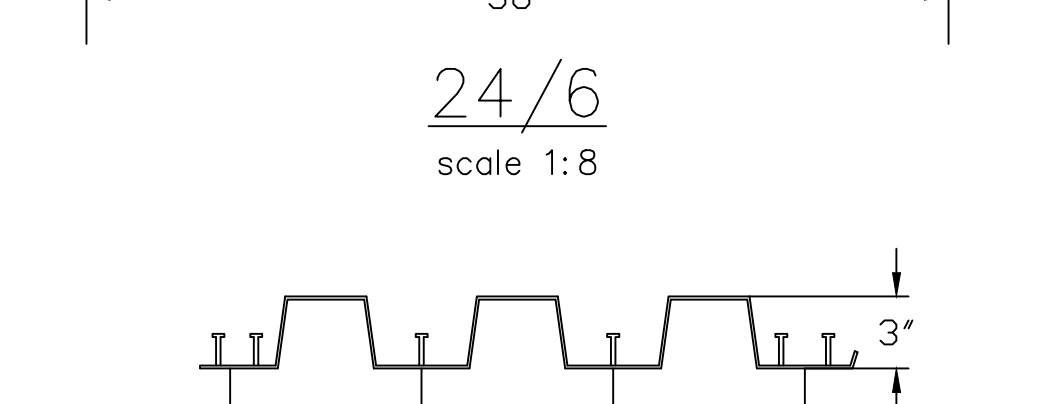
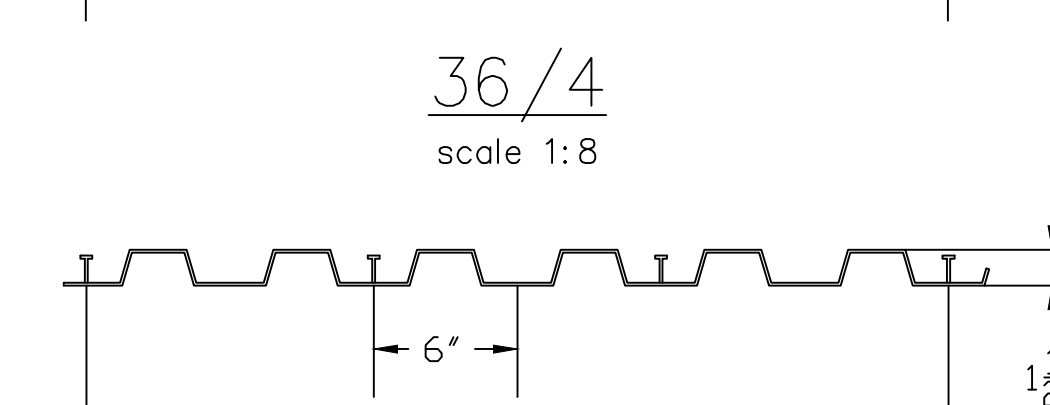
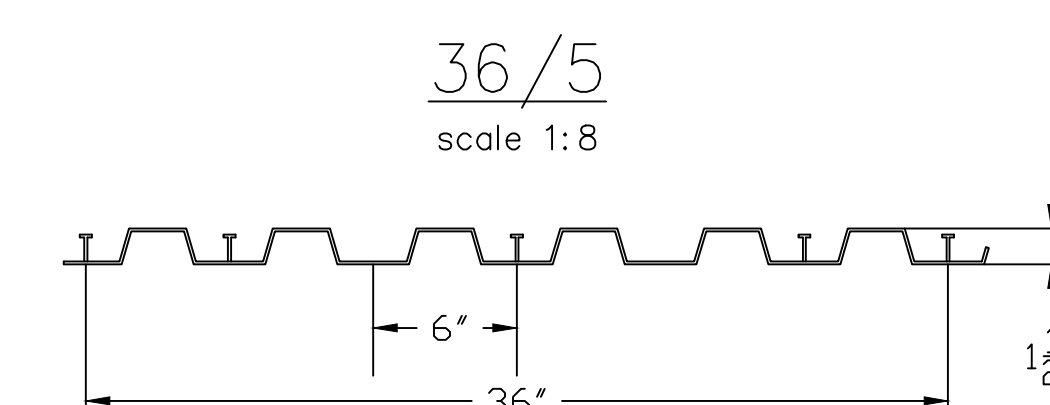
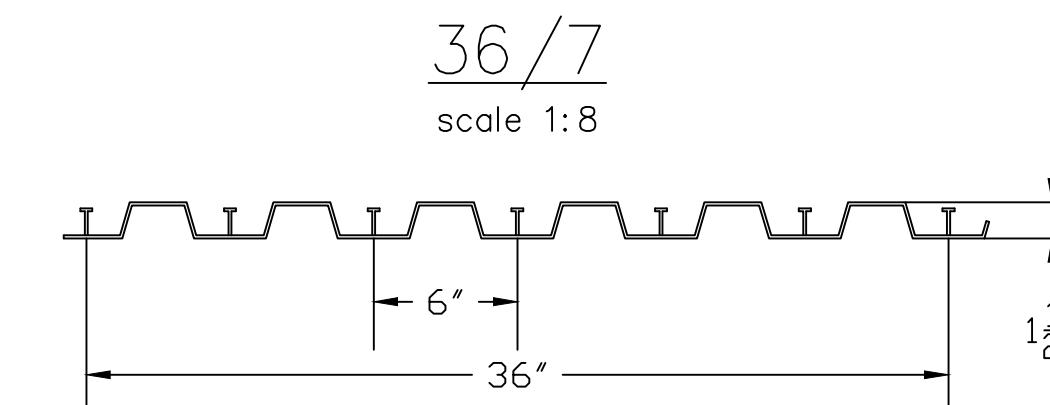
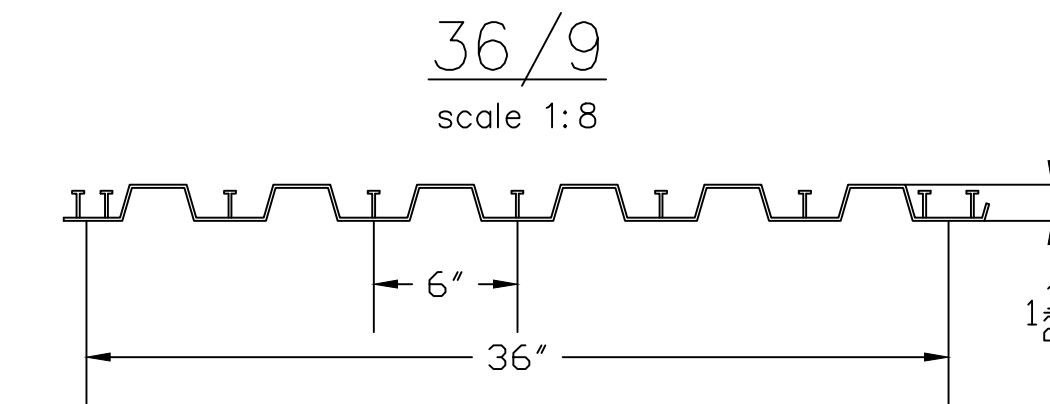
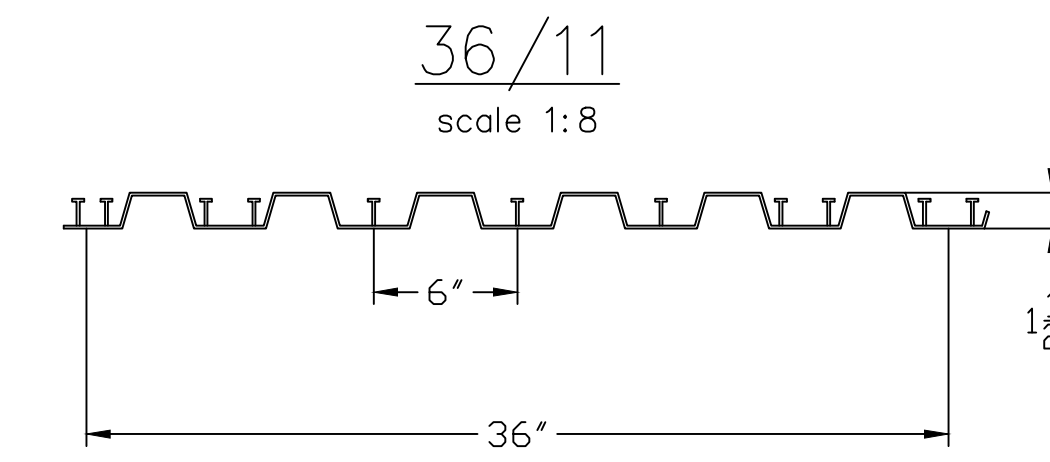
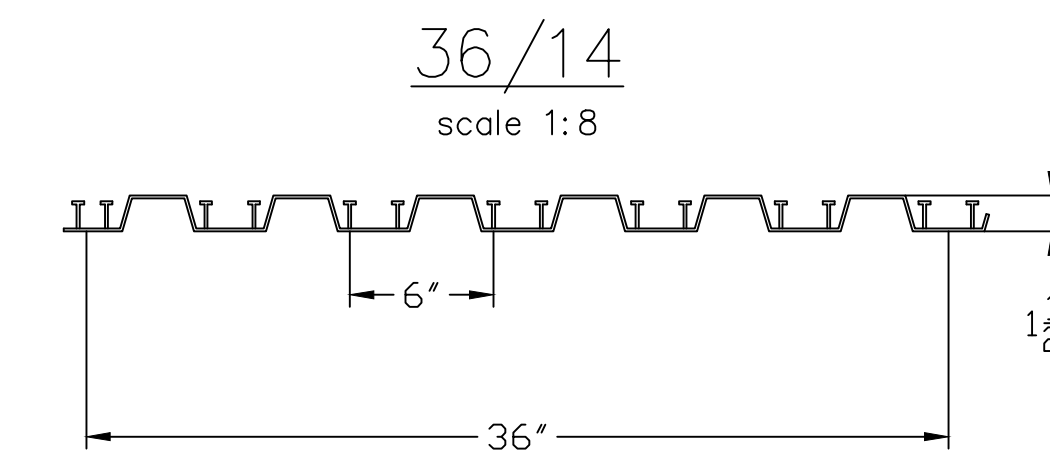

INTERLOCKING DECK

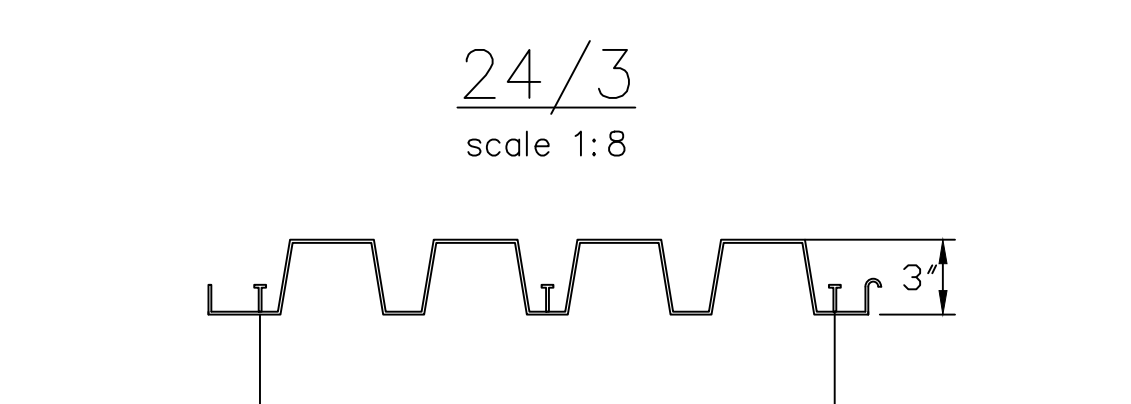
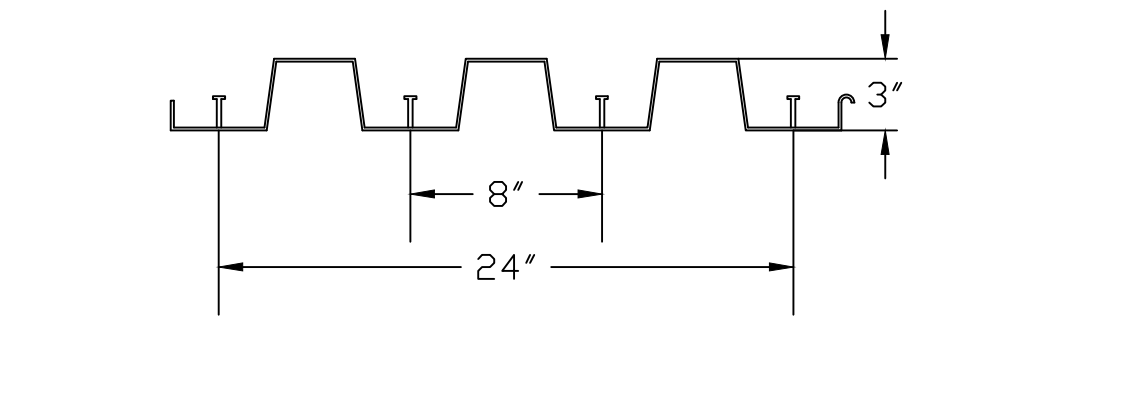
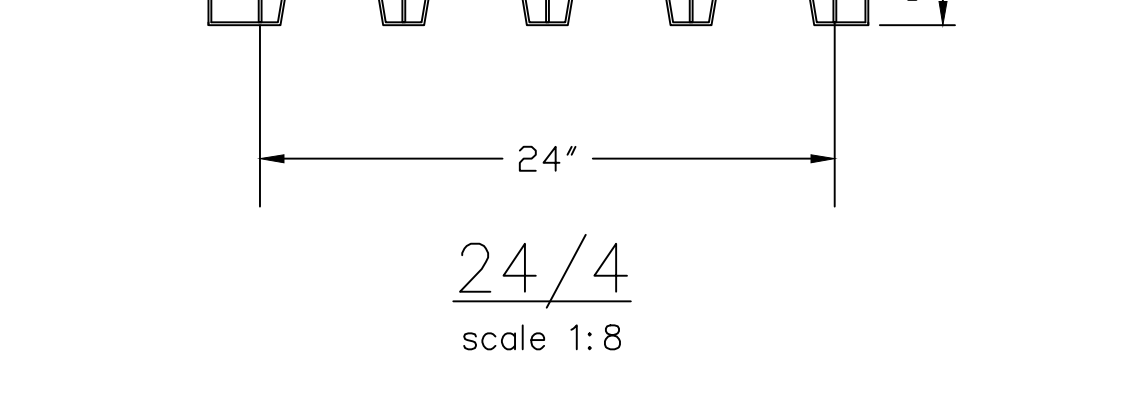
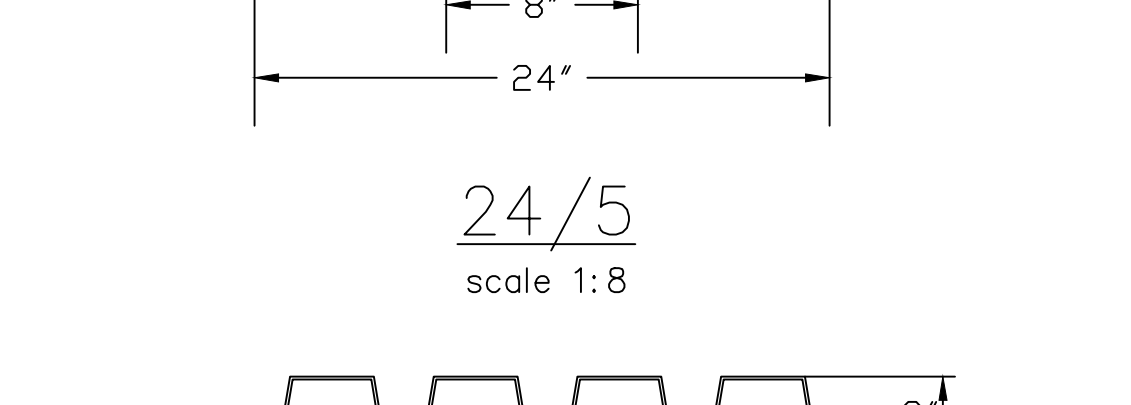
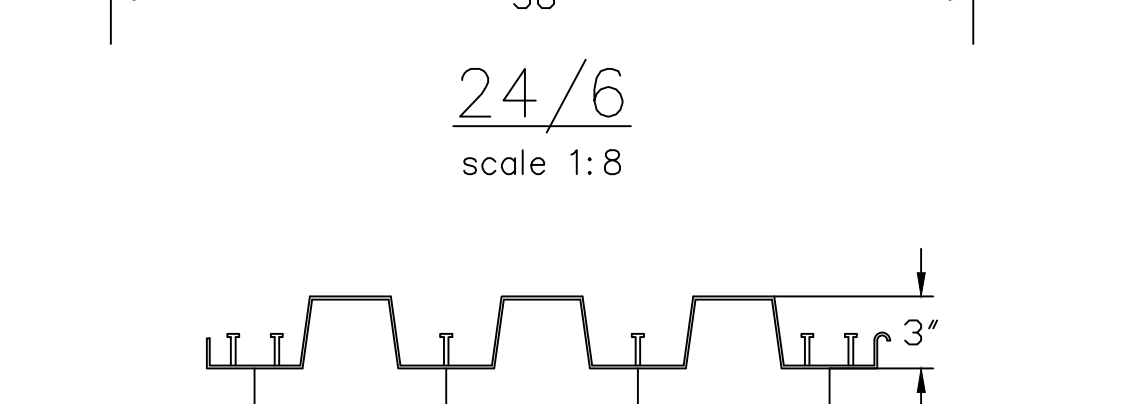
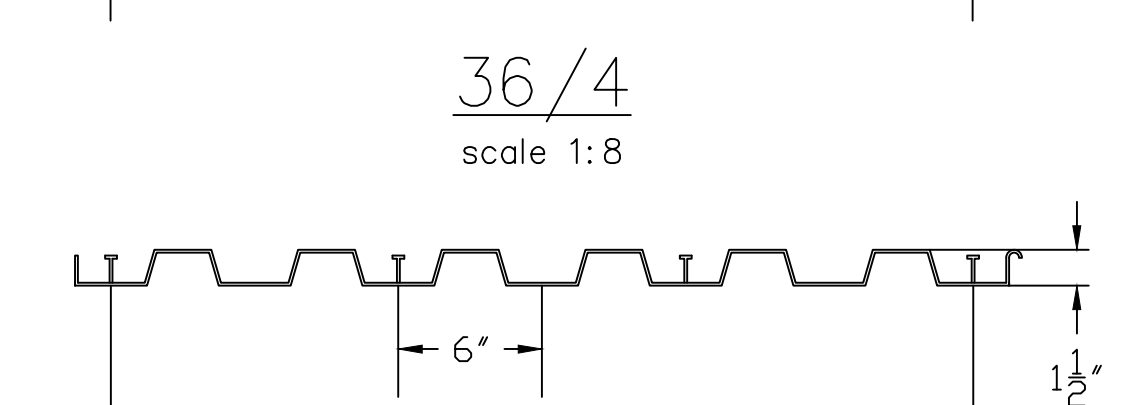
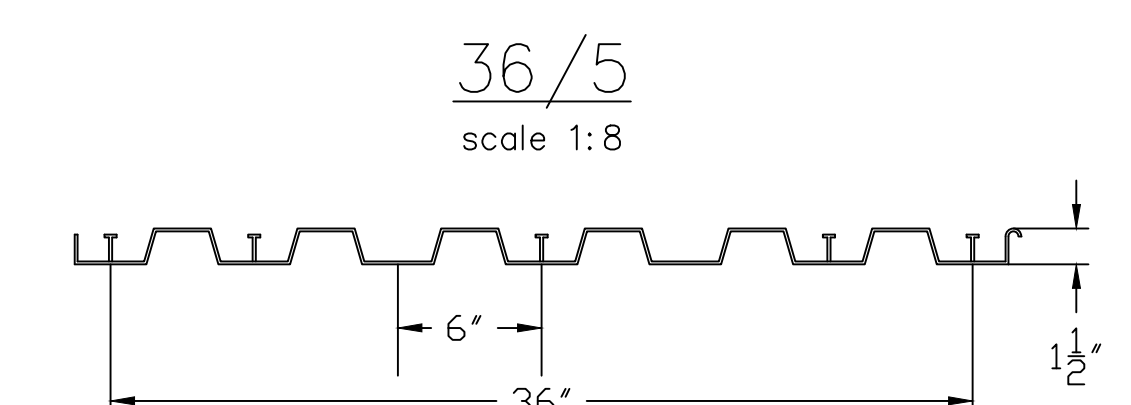
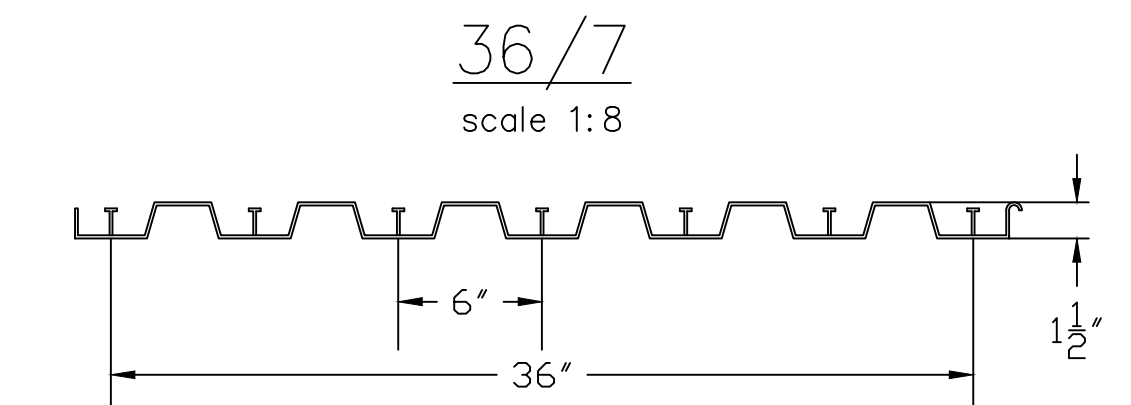
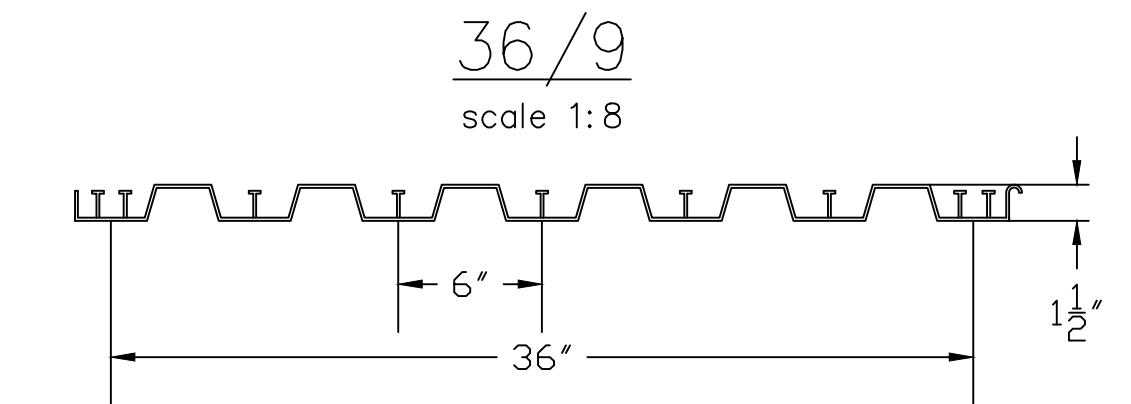
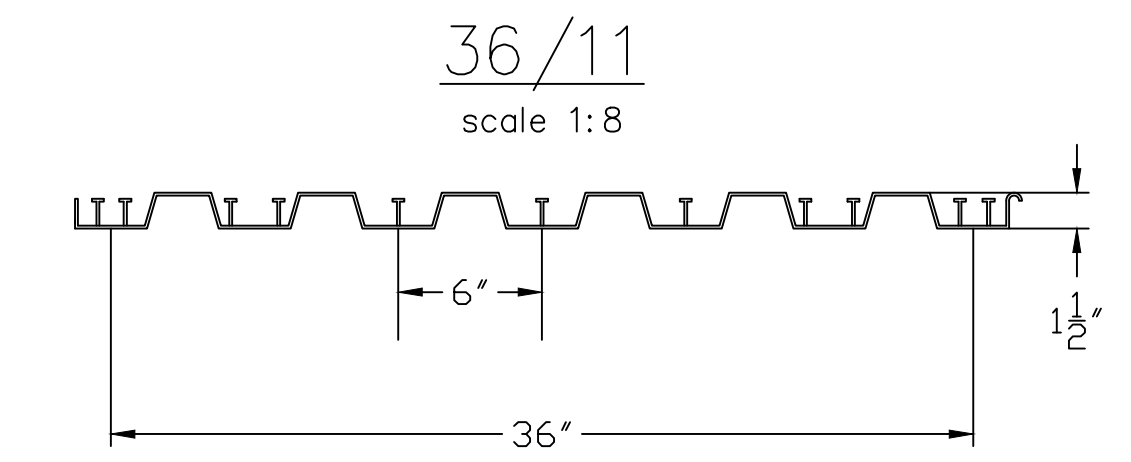
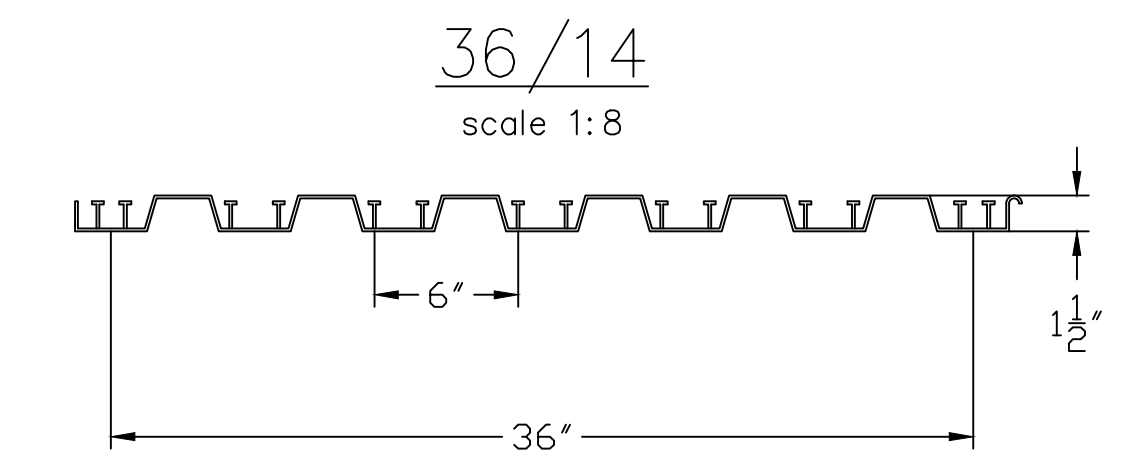

SHEET-TITLE-LINE-01
SHEET-TITLE-LINE-02
SHEET-TITLE-LINE-03
SHEET-TITLE-LINE-04

JOB-NUMBER

DRAWN:
DRAFTER

CHECKED:
CHECKER

ISSUE DATE:
DATE

REVISIONS:
REVISION-LINE-01
REVISION-LINE-02
REVISION-LINE-03
REVISION-LINE-04

SHEET NAME:
SHEET-NAME-LINE-01
SHEET-NAME-LINE-02
SHEET-NAME-LINE-03
SHEET-NAME-LINE-04

SHEET NUMBER: