



ECONOMICAL EPOXY FOR THE TRANSPORTATION INDUSTRY

Adhesive HIT-RE 10
technical supplement



PRODUCT DESCRIPTION

Mortar system



HIT-RE 10 cartridge



HAS threaded rods



Rebar

HIT-RE 10 is the newest addition to Hilti's best in class chemical anchor portfolio. This adhesive is engineered to satisfy demanding jobsite conditions for transportation doweling and anchoring at an economical price. HIT-RE 10 is ideal for roadways, bridges, railways and runway projects.

The Hilti HIT-RE 10 Adhesive Anchoring System is an injectable two-component epoxy adhesive. The two components are kept separate by means of a dual-cylinder hard plastic cartridge with an attached manifold.

HIT-RE 10 comes packaged in a new 19.6 oz. hard cartridge that integrates seamlessly with the HDM 500 manual dispenser and HDE 500 A-22 battery-powered dispenser. The automatic dosing feature provides productivity and easy installation on the jobsite. As with every Hilti anchoring product, HIT-RE 10 comes with the sales and technical service support you have come to expect from Hilti.

Product features

The Hilti HIT-RE 10 Adhesive Anchoring System may be used with fully threaded rod or deformed reinforcing bar installed in uncracked concrete. The primary features of the HIT-RE 10 Adhesive Anchoring System are:

- Suitable for post-installed rebar and threaded rod anchoring applications
- Long working time allows flexible installation
- Suitable for un-cracked concrete
- Meets requirements of ASTM C881, Type I, II, IV and V, Grade 3, Class A, B, and C
- Mixing tube provides proper mixing, helps eliminate measuring errors and minimizes waste
- Contains no styrene and virtually odorless
- Installation base material temperature range from 41°F to 104°F. For curing time based on base material temperature see the Instructions For Use

MATERIAL SPECIFICATIONS

Table 1 - Material properties of fully cured HIT-RE 10

Bond Strength ASTM C882 2 day cure 14 day cure	21.2 Mpa 23.1 Mpa	3,070 psi 3,350 psi
Compressive Strength ASTM D6951	88.1 Mpa	12,780 psi
Compressive Modulus ASTM D6951	5,380 Mpa	0.78 x 10 ⁶ psi
Tensile Strength 7 day ASTM D638	53.2 Mpa	7,720 psi
Elongation at break ASTM D638	1.30%	1.30%
Heat Deflection Temperature ASTM D648	58°C	137°F
Absorption ASTM D570	0.06%	0.06%
Linear Coefficient of Shrinkage on Cure ASTM D2566	0.0007	0.0007

TECHNICAL DATA

HIT-RE 10 Adhesive with deformed reinforcing bars (Rebar)

Figure 1 - Rebar installation conditions





Permissible base materials	Permissible concrete conditions		Permissible drilling method
			
Uncracked concrete	Dry concrete	Water saturated concrete	Hammer drilling with carbide tipped drill bit

Figure 2 - Rebar installed with HIT-RE 10 adhesive

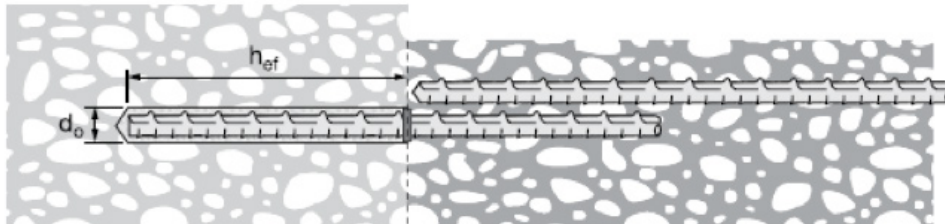

Table 2 - Specifications for rebar installed with HIT-RE 10 adhesive

Setting information	Symbol	Units	Nominal reinforcing bar size							
			#3	#4	#5	#6	#7	#8	#9	#10
Nominal bit diameter	d_0	in.	1/2	5/8	3/4	7/8	1	1-1/8	1-3/8	1-1/2
Effective minimum embedment	$h_{ef,min}$	in. (mm)	2-3/8 (60)	2-3/4 (70)	3-1/8 (79)	3-1/2 (89)	3-1/2 (89)	4 (102)	4-1/2 (114)	5 (127)
Effective maximum embedment	$h_{ef,max}$	in. (mm)	7-1/2 (190)	10 (250)	12-1/2 (310)	15 (380)	17-1/2 (440)	20 (500)	20 (500)	20 (500)
Minimum concrete thickness	h_{min}	in. (mm)	$h_{ef} + 1-1/4 > 4$ $(h_{ef} + 30 > 100)$			$h_{ef} + 2d_0$				
Minimum edge distance ¹	c_{min}	in. (mm)	1-7/8 (48)	2-1/2 (64)	3-1/8 (79)	3-3/4 (95)	4-3/8 (111)	5 (127)	5-5/8 (143)	6-1/4 (159)
Minimum anchor spacing	s_{min}	in. (mm)	1-7/8 (48)	2-1/2 (64)	3-1/8 (79)	3-3/4 (95)	4-3/8 (111)	5 (127)	5-5/8 (143)	6-1/4 (159)

¹ Edge distance of 1-3/4-inch (44mm) is permitted provided the rebar remains un-torqued.

The load values contained in Tables 4 to 13 for rebar and Tables 16 to 24 for threaded rod are Hilti Simplified Design Tables precalculated from the ACI design variables in Table 3 for rebar below and Table 15 for threaded rods. The load tables were developed using the strength design parameters and equations in accordance with ACI 318-14 Chapter 17. For a detailed explanation of the Hilti Simplified Design Tables, refer to Section 3.1.8 of The Hilti Product Technical Guide Volume 2-17.

Table 3 - Hilti HIT RE-10 design information with rebar per ACI 318-14 Ch. 17¹

Design parameter	Symbol	Units	Nominal reinforcing bar size							
			#3	#4	#5	#6	#7	#8	#9	#10
Nominal anchor diameter	d_a	in. (mm)	3/8 (9.5)	1/2 (12.7)	5/8 (15.9)	3/4 (19.1)	7/8 (22.2)	1 (25.4)	1-1/8 (28.6)	1-1/4 (31.8)
Effective minimum embedment ⁷	$h_{ef,min}$	in. (mm)	2-3/8 (60)	2-3/4 (70)	3-1/8 (79)	3-1/2 (89)	3-1/2 (89)	4 (102)	4-1/2 (114)	5 (127)
Effective maximum embedment ⁷	$h_{ef,max}$	in. (mm)	7-1/2 (190)	10 (254)	12-1/2 (318)	15 (381)	17-1/2 (445)	20 (508)	20 (508)	20 (508)
Minimum concrete thickness	h_{min}	in. (mm)	$h_{ef} + 1-1/4 > 4$ ($h_{ef} + 30 \geq 100$)			$h_{ef} + 2d_o^6$				
Critical edge distance	c_{ac}	in.	$c_{ac} = h_{ef} * \left(\frac{\tau_{k,uncr}}{1160} \right)^{0.4} * [3.1 - 0.7 * \frac{h}{h_{ef}}]$; $(\frac{h}{h_{ef}})$ need not be larger than 2.4 $\tau_{k,uncr}$ need not be taken as greater than: $\tau_{k,uncr} = \frac{k_{uncr} \sqrt{h_{ef} * f'_c}}{\pi * d_a}$							
		mm.	$c_{ac} = h_{ef} * \left(\frac{\tau_{k,uncr}}{8} \right)^{0.4} * [3.1 - 0.7 * \frac{h}{h_{ef}}]$; $(\frac{h}{h_{ef}})$ need not be larger than 2.4 $\tau_{k,uncr}$ need not be taken as greater than: $\tau_{k,uncr} = \frac{k_{uncr} \sqrt{h_{ef} * f'_c}}{\pi * d_a}$							
Minimum edge distance ²	c_{min}	in. (mm)	1-7/8 (48)	2-1/2 (64)	3-1/8 (79)	3-3/4 (95)	4-3/8 (111)	5 (127)	5-5/8 (143)	6-1/4 (159)
Minimum anchor spacing	s_{min}	in. (mm)	1-7/8 (48)	2-1/2 (64)	3-1/8 (79)	3-3/4 (95)	4-3/8 (111)	5 (127)	5-5/8 (143)	6-1/4 (159)
Effectiveness factor for uncracked concrete	$k_{c,uncr}$ ³	-	24							
Strength reduction factor for tension, concrete failure modes ⁴	$\phi_{c,N}$	-	0.65							
Strength reduction factor for shear, concrete failure modes ⁴	$\phi_{c,V}$	-	0.70							
Characteristic bond stress in uncracked concrete ⁵	$\tau_{k,uncr}$	psi (N/mm ²)	1,212 (8.4)	1,192 (8.2)	1,173 (8.1)	1,153 (8.0)	1,133 (7.8)	1,114 (7.7)	1,094 (7.5)	1,072 (7.4)
Permissible installation conditions	Strength reduction factor for tension, bond failure modes, dry concrete	Anchor category	-							
		$\phi_{b,dry}$	-							
	Strength reduction factor for tension, bond failure modes, water saturated concrete	Anchor category	-							
		$\phi_{b,ws}$	-							

¹ Design information in this table is based on testing in accordance with ACI 355.4.

² Edge distance of 1-3/4-inch (44mm) is permitted provided the rebar remains un-torqued.

³ For all design cases, $\psi_{e,N} = 1.0$. The appropriate coefficient for breakout resistance for uncracked concrete ($k_{c,uncr}$) must be used.

⁴ Values provided for post-installed anchors under Condition B without supplementary reinforcement as defined in ACI 318-14 17.3.3. For cases where the presence of supplementary reinforcement can be verified, the reduction factors associated with Condition A may be used. Maximum short term temperature = 130°F (55°C), maximum long term temperature = 110°F (43°C). Short term elevated concrete temperatures are those that occur over brief intervals, e.g., as a result of diurnal cycling. Long term concrete temperatures are roughly constant over significant periods of time.

⁵ Bond strength values corresponding to concrete compressive strength $f'_c = 2,500$ psi (17.2 MPa). For concrete compressive strength, f'_c , between 2,500 psi (17.2 MPa) and 8,000 psi (55.2 MPa), the tabulated characteristic bond strength may be increased by a factor of $(f'_c/2,500)^{0.26}$. (for SI: $(f'_c/17.2)^{0.26}$).

⁶ d_o = drilled hole diameter, see figure 2.

⁷ See figure 2.

Table 4 - Hilti HIT-RE 10 adhesive design strength with concrete / bond failure for US rebar in uncracked concrete ^{1,2,3,4,5,6,7,8}

Rebar size	Effective embedment in. (mm)	Tension - ΦN_n				Shear - ΦV_n			
		$f'_c = 2500$ psi (17.2 Mpa) lb (kN)	$f'_c = 3000$ psi (20.7 Mpa) lb (kN)	$f'_c = 4000$ psi (27.6 Mpa) lb (kN)	$f'_c = 6000$ psi (41.4 Mpa) lb (kN)	$f'_c = 2500$ psi (17.2 Mpa) lb (kN)	$f'_c = 3000$ psi (20.7 Mpa) lb (kN)	$f'_c = 4000$ psi (27.6 Mpa) lb (kN)	$f'_c = 6000$ psi (41.4 Mpa) lb (kN)
#3	3-3/8 (86)	2,650 (11.8)	2,780 (12.4)	2,995 (13.3)	3,330 (14.8)	6,745 (30.0)	7,075 (31.5)	7,625 (33.9)	8,470 (37.7)
	4-1/2 (114)	3,535 (15.7)	3,705 (16.5)	3,995 (17.8)	4,435 (19.7)	8,995 (40.0)	9,430 (41.9)	10,165 (45.2)	11,295 (50.2)
	7-1/2 (190)	5,890 (26.2)	6,175 (27.5)	6,655 (29.6)	7,395 (32.9)	14,990 (66.7)	15,720 (69.9)	16,940 (75.4)	18,825 (83.7)
#4	4-1/2 (114)	4,635 (20.6)	4,860 (21.6)	5,235 (23.3)	5,820 (25.9)	11,795 (52.5)	12,370 (55.0)	13,330 (59.3)	14,810 (65.9)
	6 (152)	6,180 (27.5)	6,480 (28.8)	6,980 (31.0)	7,760 (34.5)	15,730 (70.0)	16,490 (73.4)	17,770 (79.0)	19,750 (87.9)
	10 (254)	10,300 (45.8)	10,800 (48.0)	11,635 (51.8)	12,930 (57.5)	26,215 (116.6)	27,485 (122.3)	29,620 (131.8)	32,915 (146.4)
#5	5-5/8 (143)	7,125 (31.7)	7,470 (33.2)	8,050 (35.8)	8,945 (39.8)	18,140 (80.7)	19,020 (84.6)	20,495 (91.2)	22,775 (101.3)
	7-1/2 (191)	9,500 (42.3)	9,960 (44.3)	10,735 (47.8)	11,930 (53.1)	24,185 (107.6)	25,355 (112.8)	27,325 (121.5)	30,365 (135.1)
	12-1/2 (318)	15,835 (70.4)	16,605 (73.9)	17,895 (79.6)	19,880 (88.4)	40,305 (179.3)	42,260 (188.0)	45,545 (202.6)	50,610 (225.1)
#6	6-3/4 (171)	10,085 (44.9)	10,575 (47.0)	11,395 (50.7)	12,665 (56.3)	25,675 (114.2)	26,920 (119.7)	29,010 (129.0)	32,235 (143.4)
	9 (229)	13,450 (59.8)	14,100 (62.7)	15,195 (67.6)	16,885 (75.1)	34,230 (152.3)	35,890 (159.6)	38,680 (172.1)	42,980 (191.2)
	15 (381)	22,415 (99.7)	23,500 (104.5)	25,325 (112.7)	28,140 (125.2)	57,050 (253.8)	59,820 (266.1)	64,465 (286.8)	71,635 (318.6)
#7	7-7/8 (200)	13,490 (60.0)	14,145 (62.9)	15,245 (67.8)	16,940 (75.4)	34,335 (152.7)	36,005 (160.2)	38,800 (172.6)	43,115 (191.8)
	10-1/2 (267)	17,985 (80.0)	18,860 (83.9)	20,325 (90.4)	22,585 (100.5)	45,785 (203.7)	48,005 (213.5)	51,735 (230.1)	57,485 (255.7)
	17-1/2 (445)	29,975 (133.3)	31,430 (139.8)	33,875 (150.7)	37,640 (167.4)	76,305 (339.4)	80,010 (355.9)	86,225 (383.5)	95,810 (426.2)
#8	9 (229)	17,325 (77.1)	18,165 (80.8)	19,575 (87.1)	21,750 (96.7)	44,095 (196.1)	46,235 (205.7)	49,830 (221.7)	55,370 (246.3)
	12 (305)	23,100 (102.8)	24,220 (107.7)	26,100 (116.1)	29,000 (129.0)	58,795 (261.5)	61,650 (274.2)	66,440 (295.5)	73,825 (328.4)
	20 (508)	38,495 (171.2)	39,205 (174.4)	40,350 (179.5)	42,020 (186.9)	97,995 (435.9)	99,795 (443.9)	102,710 (456.9)	106,960 (475.8)
#9	10-1/8 (257)	21,530 (95.8)	21,930 (97.5)	22,570 (100.4)	23,500 (104.5)	54,125 (240.8)	55,815 (248.3)	57,445 (255.5)	59,820 (266.1)
	13-1/2 (343)	28,710 (127.7)	29,235 (130.0)	30,090 (133.8)	31,335 (139.4)	73,075 (325.1)	74,420 (331.0)	76,595 (340.7)	79,765 (354.8)
	20 (508)	42,530 (189.2)	43,315 (192.7)	44,580 (198.3)	46,425 (206.5)	108,260 (481.6)	110,255 (490.4)	113,470 (504.7)	118,170 (525.6)
#10	11-1/4 (286)	26,050 (115.9)	26,525 (118.0)	27,300 (121.4)	28,430 (126.5)	63,395 (282.0)	67,525 (300.4)	69,495 (309.1)	72,370 (321.9)
	15 (381)	34,730 (154.5)	35,370 (157.3)	36,400 (161.9)	37,910 (168.6)	88,405 (393.2)	90,030 (400.5)	92,660 (412.2)	96,495 (429.2)
	20 (508)	46,305 (206.0)	47,160 (209.8)	48,535 (215.9)	50,545 (224.8)	117,875 (524.3)	120,040 (534.0)	123,545 (549.6)	128,655 (572.3)

¹ See Section 3.1.8 of Hilti Product Technical Guide Volume 2-17 for explanation on development of load values.

² See Section 3.1.8.6 of Hilti Product Technical Guide Volume 2-17 to convert design strength value to ASD value.

³ Linear interpolation between embedment depths and concrete compressive strengths is not permitted.

⁴ Apply spacing, edge distance, and concrete thickness factors in tables 6-13 as necessary. Compare to the steel values in table 5. The lesser of the values is to be used for the design.

⁵ Data is for maximum short term temperature = 130°F (55°C), maximum long term temperature = 110°F (43°C). Short term elevated concrete temperatures are those that occur over brief intervals, e.g., as a result of diurnal cycling. Long term concrete temperatures are roughly constant over significant periods of time.

⁶ Tabular values are for dry concrete or water saturated concrete conditions.

⁷ Tabular values are for short term loads only. For sustained loads including overhead use, see Section 3.1.8.8 Hilti Product Technical Guide Volume 2

⁸ Tabular values are for normal-weight concrete only. For lightweight concrete multiply design strength by λ_s as follows:

For sand-lightweight, $\lambda_s = 0.51$. For all-lightweight, $\lambda_s = 0.45$.

Table 5 - Steel design strength for US rebar ^{1,2}

Rebar size	ASTM A 615 Grade 40		ASTM A 615 Grade 60		ASTM A 706 Grade 60	
	Tensile ³ ΦN_{sa} lb (kN)	Shear ⁴ ΦV_{sa} lb (kN)	Tensile ³ ΦN_{sa} lb (kN)	Shear ⁴ ΦV_{sa} lb (kN)	Tensile ³ ΦN_{sa} lb (kN)	Shear ⁴ ΦV_{sa} lb (kN)
#3	4,290 (19.1)	2,375 (10.6)	6,435 (28.6)	3,565 (15.9)	6,600 (29.4)	3,430 (15.3)
#4	7,800 (34.7)	4,320 (19.2)	11,700 (52.0)	6,480 (28.8)	12,000 (53.4)	6,240 (27.8)
#5	12,090 (53.8)	6,695 (29.8)	18,135 (80.7)	10,045 (44.7)	18,600 (82.7)	9,670 (43.0)
#6	17,160 (76.3)	9,505 (42.3)	25,740 (114.5)	14,255 (63.4)	26,400 (117.4)	13,730 (61.1)
#7	23,400 (104.1)	12,960 (57.6)	35,100 (156.1)	19,440 (86.5)	36,000 (160.1)	18,720 (83.3)
#8	30,810 (137.0)	17,065 (75.9)	46,215 (205.6)	25,595 (113.9)	47,400 (210.8)	24,650 (109.6)
#9	39,000 (173.5)	21,600 (96.1)	58,500 (260.2)	32,400 (144.1)	60,000 (266.9)	31,200 (138.8)
#10	49,530 (220.3)	27,430 (122.0)	74,295 (330.5)	41,150 (183.0)	76,200 (339.0)	39,625 (176.3)

¹ See Section 3.1.8.6 of Hilti Product Technical Guide Volume 2 to convert design strength value to ASD value.

² ASTM A706 Grade 60 rebar are considered ductile steel elements. ASTM A 615 Grade 40 and 60 rebar are considered brittle steel elements.

³ Tensile = $\phi A_{sb,N} f_{UB}$ as noted in ACI 318 Chapter 17

⁴ Shear = $\phi 0.60 A_{sb,N} f_{UB}$ as noted in ACI 318 Chapter 17

Hilti HIT-RE 10 Adhesive with Hilti HAS threaded rod

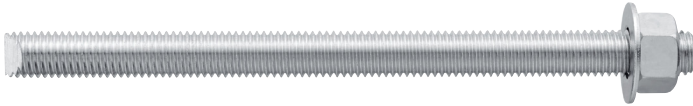

Figure 3 – HAS threaded rod installation conditions







Permissible base materials	Permissible concrete conditions		Permissible drilling method
			
Uncracked concrete	Dry concrete	Water saturated concrete	Hammer drilling with carbide tipped drill bit

Table 14 - Hilti HAS Threaded Rod Installation Specifications when installed with HIT-RE 10 adhesive system

Setting information	Symbol	Units	Nominal rod diameter, (in.)						
			3/8	1/2	5/8	3/4	7/8	1	1-1/4
Nominal bit diameter	d_0	in.	7/16	9/16	3/4	7/8	1	1-1/8	1-3/8
Effective minimum embedment	$h_{ef,min}$	in. (mm)	2-3/8 (60)	2-3/4 (70)	3-1/8 (79)	3-1/2 (89)	3-1/2 (89)	4 (102)	5 (127)
Effective maximum embedment	$h_{ef,max}$	in. (mm)	7-1/2 (190)	10 (250)	12-1/2 (310)	15 (380)	17-1/2 (440)	20 (500)	20 (500)
Minimum diameter of fixture hole	through-set 	in.	1/2	5/8	13/16 ¹	15/16 ¹	1-1/8 ¹	1-1/4 ¹	1-1/2 ¹
	preset 	in.	7/16	9/16	11/16	13/16	15/16	1-1/8	1-3/8
Installation Torque	T_{inst}	ft-lb. (N-m)	15 (20)	30 (41)	60 (81)	100 (136)	125 (169)	150 (203)	200 (271)
Minimum concrete thickness	h_{min}	in. (mm)	$h_{ef} + 1-1/4 > 4$ $(h_{ef} + 30 > 100)$			$h_{ef} + 2d_0$			
Minimum edge distance ²	c_{min}	in. (mm)	1-7/8 (48)	2-1/2 (64)	3-1/8 (79)	3-3/4 (95)	4-3/8 (111)	5 (127)	5-5/8 (143)
Minimum anchor spacing	s_{min}	in. (mm)	1-7/8 (48)	2-1/2 (64)	3-1/8 (79)	3-3/4 (95)	4-3/8 (111)	5 (127)	5-5/8 (143)

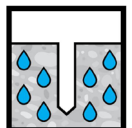
¹ Install using (2) washers. See Figure 5.

² Edge distance of 1-3/4-inch (44mm) is permitted provided the installation torque is reduced to 0.30 T_{inst} for $5d < s < 16$ in. and to 0.5 T_{inst} for $s > 16$ -in.

Figure 4 - Hilti HAS threaded rods

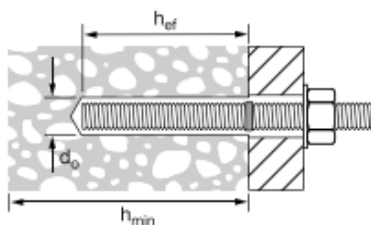

Figure 5 - Illustration with (2) washers



Table 15 - Hilti HIT-RE 10 design information with HAS threaded rods per ACI 318-14 Ch. 17 ¹

Design parameter	Symbol	Units	Nominal rod diameter (in.)							
			3/8	1/2	5/8	3/4	7/8	1	1-1/4	
Nominal anchor diameter	d_a	in. (mm)	3/8 (9.5)	1/2 (12.7)	5/8 (15.9)	3/4 (19.1)	7/8 (22.2)	1 (25.4)	1-1/4 (31.8)	
Effective minimum embedment ⁷	$h_{ef,min}$	in. (mm)	2-3/8 (60)	2-3/4 (70)	3-1/8 (79)	3-1/2 (89)	3-1/2 (89)	4 (102)	5 (127)	
Effective maximum embedment ⁷	$h_{ef,max}$	in. (mm)	7-1/2 (190)	10 (254)	12-1/2 (318)	15 (381)	17-1/2 (445)	20 (508)	20 (508)	
Minimum concrete thickness ⁷	h_{min}	in. (mm)	$h_{ef} + 1-1/4 > 4$ ($h_{ef} + 30 \geq 100$)			$h_{ef} + 2d_o$ ⁶				
Critical edge distance	c_{ac}	in.	$c_{ac} = h_{ef} * \left(\frac{\tau_{k,unscr}}{1160} \right)^{0.4} * \left[3.1 - 0.7 * \frac{h}{h_{ef}} \right]; \left(\frac{h}{h_{ef}} \right)$ need not be larger than 2.4 $\tau_{k,unscr}$ need not be taken as greater than: $\tau_{k,unscr} = \frac{k_{unscr} \sqrt{h_{hef} * f'_c}}{\pi * d_a}$							
		mm.	$c_{ac} = h_{ef} * \left(\frac{\tau_{k,unscr}}{8} \right)^{0.4} * \left[3.1 - 0.7 * \frac{h}{h_{ef}} \right]; \left(\frac{h}{h_{ef}} \right)$ need not be larger than 2.4 $\tau_{k,unscr}$ need not be taken as greater than: $\tau_{k,unscr} = \frac{k_{unscr} \sqrt{h_{hef} * f'_c}}{\pi * d_a}$							
Minimum edge distance ²	c_{min}	in. (mm)	1-7/8 (48)	2-1/2 (64)	3-1/8 (79)	3-3/4 (95)	4-3/8 (111)	5 (127)	5-5/8 (143)	
Minimum anchor spacing	s_{min}	in. (mm)	1-7/8 (48)	2-1/2 (64)	3-1/8 (79)	3-3/4 (95)	4-3/8 (111)	5 (127)	5-5/8 (143)	
Effectiveness factor for uncracked concrete	$k_{c,unscr}$ ⁴	-	24							
Strength reduction factor for tension, concrete failure modes	$\phi_{c,N}$	-	0.65							
Strength reduction factor for shear, concrete failure modes	$\phi_{c,V}$	-	0.70							
Characteristic bond stress in uncracked concrete ⁵	$\tau_{k,unscr}$	psi (N/mm ²)	1,246 (8.6)	1,191 (8.2)	1,136 (7.8)	1,082 (7.5)	1,029 (7.1)	974 (6.7)	864 (6.0)	
Permissible installation conditions	Strength reduction factor for tension, bond failure modes, dry concrete	Anchor category	-	2	2	3	3	3	3	3
		$\phi_{b,dry}$	-	0.55	0.55	0.45	0.45	0.45	0.45	0.45
	Strength reduction factor for tension, bond failure modes, water saturated concrete	Anchor category	-	2	2	3	3	3	3	3
		$\phi_{b,ws}$	-	0.55	0.55	0.45	0.45	0.45	0.45	0.45

¹ Design information in this table is based on testing in accordance with ACI 355.4.

² Edge distance of 1-3/4-inch (44mm) is permitted provided the rebar remains un-torqued.

³ For all design cases, $\psi_{c,N} = 1.0$. The appropriate coefficient for breakout resistance for uncracked concrete ($k_{c,unscr}$) must be used.

⁴ Values provided for post-installed anchors under Condition B without supplementary reinforcement as defined in ACI 318-14 17.3.3. For cases where the presence of supplementary reinforcement can be verified, the reduction factors associated with Condition A may be used. Temperature range B: Maximum short term temperature = 130°F(55°C), maximum long term temperature = 110°F(43°C). Short term elevated concrete temperatures are those that occur over brief intervals, e.g., as a result of diurnal cycling. Long term concrete temperatures are roughly constant over significant periods of time.

⁵ Bond strength values corresponding to concrete compressive strength $f'_c = 2500$ Psi. For concrete compressive strength, f'_c , between 2500 Psi and 8000 Psi, the tabulated characteristic bond strength may be increased by a factor of $(f'_c/2500)^{0.15}$

⁶ d_o = drilled hole diameter, see figure 4.

⁷ See Figure 4.

Table 16 - Hilti RE 10 adhesive design strength with concrete / bond failure for threaded rod in uncracked concrete ^{1,2,3,4,5,6,7,8}

Nominal anchor diameter in.	Effective embedment in. (mm)	Tension - ΦN_n				Shear - ΦV_n			
		$f'_c = 2500$ psi (17.2 Mpa) lb (kN)	$f'_c = 3000$ psi (20.7 Mpa) lb (kN)	$f'_c = 4000$ psi (17.2 Mpa) lb (kN)	$f'_c = 6000$ psi (41.4 Mpa) lb (kN)	$f'_c = 2500$ psi (17.2 Mpa) lb (kN)	$f'_c = 3000$ psi (20.7 Mpa) lb (kN)	$f'_c = 4000$ psi (17.2 Mpa) lb (kN)	$f'_c = 6000$ psi (41.4 Mpa) lb (kN)
3/8	2-3/8 (60)	1,915 (8.5)	1,955 (8.7)	2,010 (8.9)	2,095 (9.3)	2,440 (10.9)	2,485 (11.1)	2,560 (11.4)	2,665 (11.9)
	3-3/8 (86)	2,725 (12.1)	2,775 (12.3)	2,855 (12.7)	2,975 (13.2)	6,935 (30.8)	7,065 (31.4)	7,270 (32.3)	7,570 (33.7)
	4-1/2 (114)	3,635 (16.2)	3,700 (16.5)	3,810 (16.9)	3,965 (17.6)	9,250 (41.1)	9,420 (41.9)	9,695 (43.1)	10,095 (44.9)
	7-1/2 (190)	6,055 (26.9)	6,165 (27.4)	6,345 (28.2)	6,610 (29.4)	15,415 (68.6)	15,695 (69.8)	16,155 (71.9)	16,825 (74.8)
1/2	2-3/4 (70)	2,830 (12.6)	2,880 (12.8)	2,965 (13.2)	3,090 (13.7)	7,205 (32.0)	7,335 (32.6)	7,550 (33.6)	7,860 (35.0)
	4-1/2 (114)	4,630 (20.6)	4,715 (21.0)	4,855 (21.6)	5,055 (22.5)	11,785 (52.4)	12,005 (53.4)	12,355 (55.0)	12,865 (57.2)
	6 (152)	6,175 (27.5)	6,285 (28.0)	6,470 (28.8)	6,740 (30.0)	15,715 (69.9)	16,005 (71.2)	16,470 (73.3)	17,155 (76.3)
	10 (254)	10,290 (45.8)	10,480 (46.6)	10,785 (48.0)	11,230 (50.0)	26,190 (116.5)	26,675 (118.7)	27,450 (122.1)	28,590 (127.2)
5/8	3-1/8 (79)	3,135 (13.9)	3,195 (14.2)	3,290 (14.6)	3,425 (15.2)	9,280 (41.3)	9,940 (44.2)	10,230 (45.5)	10,650 (47.4)
	5-5/8 (143)	5,645 (25.1)	5,750 (25.6)	5,920 (26.3)	6,165 (27.4)	17,565 (78.1)	17,890 (79.6)	18,410 (81.9)	19,175 (85.3)
	7-1/2 (191)	7,530 (33.5)	7,665 (34.1)	7,890 (35.1)	8,215 (36.5)	23,420 (104.2)	23,850 (106.1)	24,550 (109.2)	25,565 (113.7)
	12-1/2 (318)	12,545 (55.8)	12,780 (56.8)	13,150 (58.5)	13,695 (60.9)	39,035 (173.6)	39,750 (176.8)	40,915 (182.0)	42,605 (189.5)
3/4	3-1/2 (89)	4,015 (17.9)	4,090 (18.2)	4,210 (18.7)	4,385 (19.5)	11,000 (48.9)	12,050 (53.6)	13,095 (58.2)	13,635 (60.7)
	6-3/4 (171)	7,745 (34.5)	7,960 (35.4)	8,310 (37.0)	8,830 (39.3)	24,090 (107.2)	24,760 (110.1)	25,850 (115.0)	27,475 (122.2)
	9 (229)	10,325 (45.9)	10,610 (47.2)	11,080 (49.3)	11,775 (52.4)	32,120 (142.9)	33,015 (146.9)	34,470 (153.3)	36,630 (162.9)
	15 (381)	17,210 (76.6)	17,685 (78.7)	18,465 (82.1)	19,625 (87.3)	53,535 (238.1)	55,020 (244.7)	57,450 (255.5)	61,050 (271.6)
7/8	3-1/2 (89)	4,455 (19.8)	4,580 (20.4)	4,780 (21.3)	4,980 (22.2)	11,000 (48.9)	12,050 (53.6)	13,915 (61.9)	15,805 (70.3)
	7-7/8 (200)	10,025 (44.6)	10,300 (45.8)	10,755 (47.8)	11,430 (50.8)	31,185 (138.7)	32,050 (142.6)	33,465 (148.9)	35,560 (158.2)
	10-1/2 (267)	13,365 (59.5)	13,735 (61.1)	14,340 (63.8)	15,240 (67.8)	41,580 (185.0)	42,735 (190.1)	44,620 (198.5)	47,415 (210.9)
	17-1/2 (445)	22,275 (99.1)	22,895 (101.8)	23,900 (106.3)	25,400 (113.0)	69,300 (308.3)	71,220 (316.8)	74,365 (330.8)	79,025 (351.5)
1	4 (102)	5,510 (24.5)	5,660 (25.2)	5,910 (26.3)	6,280 (27.9)	13,440 (59.8)	14,725 (65.5)	17,000 (75.6)	19,540 (86.9)
	9 (229)	12,395 (55.1)	12,735 (56.6)	13,300 (59.2)	14,130 (62.9)	38,555 (171.5)	39,625 (176.3)	41,370 (184.0)	43,965 (195.6)
	12 (305)	16,525 (73.5)	16,980 (75.5)	17,730 (78.9)	18,840 (83.8)	51,405 (228.7)	52,830 (235.0)	55,160 (245.4)	58,620 (260.8)
	20 (508)	27,540 (122.5)	28,305 (125.9)	29,550 (131.4)	31,405 (139.7)	85,680 (381.1)	88,055 (391.7)	91,935 (408.9)	97,700 (Tqtable 16)
1-1/4	5 (127)	7,635 (34.0)	7,845 (34.9)	8,190 (36.4)	8,705 (38.7)	18,785 (83.6)	20,575 (91.5)	23,760 (105.7)	27,085 (120.5)
	11-1/4 (286)	17,175 (76.4)	17,655 (78.5)	18,430 (82.0)	19,585 (87.1)	53,440 (237.7)	54,920 (244.3)	57,340 (255.1)	60,940 (271.1)
	15 (381)	22,900 (101.9)	23,535 (104.7)	24,575 (109.3)	26,115 (116.2)	71,250 (316.9)	73,225 (325.7)	76,455 (340.1)	81,250 (361.4)
	20 (508)	30,535 (135.8)	31,385 (139.6)	32,765 (145.7)	34,820 (154.9)	95,000 (422.6)	97,635 (434.3)	101,940 (453.4)	108,335 (481.9)

¹ See Section 3.1.8 of Hilti Product Technical Guide 17 Volume 2 for explanation on development of load values.

² See Section 3.1.8.6 of Hilti Product Technical Guide 17 Volume 2 to convert design strength value to ASD value.

³ Linear interpolation between embedment depths and concrete compressive strengths is not permitted.

⁴ Apply spacing, edge distance, and concrete thickness factors in tables 18-23 as necessary. Compare to the steel values in table 17. The lesser of the values is to be used for the design.

⁵ Data is for maximum short term temperature = 130°F (55°C), maximum long term temperature = 110°F (43°C). Short term elevated concrete temperatures are those that occur over brief intervals, e.g., as a result of diurnal cycling. Long term concrete temperatures are roughly constant over significant periods of time.

⁶ Tabular values are for dry concrete or water-saturated concrete conditions.

⁷ Tabular values are for short term loads only. For sustained loads including overhead use, see Section 3.1.8.8 of Hilti Product Technical Guide 17 Volume 2.

⁸ Tabular values are for normal weight concrete only. For lightweight concrete multiply design strength by λ_n as follows: For sand-lightweight, $\lambda_n = 0.51$. For all-lightweight, $\lambda_n = 0.45$.

Table 17 - Steel design strength for Hilti HAS threaded rods for use with ACI 318-14 Chapter 17

Nominal anchor diameter in.	HAS-V-36 / HAS-V-36 HDG ASTM F1554 Gr. 36 ^{3,5}		HAS-E-55 / HAS-E-55 HDG ASTM F1554 Gr. 55 ^{3,5}		HAS-B-105 / HAS-B-105 HDG ASTM A193 B7 and ASTM F 1554 Gr. 105 ^{3,5}		HAS-R Stainless Steel ASTM F593 (3/8-in to 1-in) ⁴ ASTM A193 (1-1/4-in) ³	
	Tensile ¹ ΦN _{sa} lb (kN)	Shear ² ΦV _{sa} lb (kN)	Tensile ¹ ΦN _{sa} lb (kN)	Shear ² ΦV _{sa} lb (kN)	Tensile ¹ ΦN _{sa} lb (kN)	Shear ² ΦV _{sa} lb (kN)	Tensile ¹ ΦN _{sa} lb (kN)	Shear ² ΦV _{sa} lb (kN)
3/8	3,370 (15.0)	1,750 (7.8)	4,360 (19.4)	2,270 (10.1)	7,270 (32.3)	3,780 (16.8)	5,040 (22.4)	2,790 (12.4)
1/2	6,175 (27.5)	3,210 (14.3)	7,985 (35.5)	4,150 (18.5)	13,305 (59.2)	6,920 (30.8)	9,225 (41.0)	5,110 (22.7)
5/8	9,835 (43.7)	5,110 (22.7)	12,715 (56.6)	6,610 (29.4)	21,190 (94.3)	11,020 (49.0)	14,690 (65.3)	8,135 (36.2)
3/4	14,550 (64.7)	7,565 (33.7)	18,820 (83.7)	9,785 (43.5)	31,360 (139.5)	16,310 (72.6)	18,485 (82.2)	10,235 (45.5)
7/8	20,085 (89.3)	10,445 (46.5)	25,975 (115.5)	13,505 (60.1)	43,285 (192.5)	22,510 (100.1)	25,510 (113.5)	14,125 (62.8)
1	26,350 (117.2)	13,700 (60.9)	34,075 (151.6)	17,720 (78.8)	56,785 (252.6)	29,530 (131.4)	33,465 (148.9)	18,535 (82.4)
1-1/4	42,160 (187.5)	21,920 (97.5)	54,515 (242.5)	28,345 (126.1)	90,855 (404.1)	47,245 (210.2)	41,430 (184.3)	21,545 (95.8)

¹ Tensile = $\phi A_{sa}N f_{uta}$ as noted in ACI 318-14 17.4.1.2

² Shear = $\phi 0.60 A_{sa}V f_{uta}$ as noted in ACI 318-14 17.5.1.2b.

³ HAS-V, HAS-E (3/8-in to 1-1/4-in), HAS-B, and HAS-R (Class 1; 1-1/4-in) threaded rods are considered ductile steel elements (included HDG rods).

⁴ HAS-R (CW1 and CW2; 3/8-in to 1-in) threaded rods are considered brittle steel elements (including HDG rods).

⁵ 3/8-inch dia. threaded rods are not included in the ASTM F1554 standard. Hilti 3/8-inch dia. HAS-V, HAS-E, and HAS-B (incl. HDG) threaded rods meet the chemical composition and mechanical property requirements of ASTM F1554.

Table 24 - Load adjustment factors for 1-1/4-in. diameter threaded rods in uncracked concrete ^{1,2,3}

1-1/4-in. uncracked concrete	Spacing factor in tension f_{AN}				Edge distance factor in tension f_{RN}				Spacing factor in shear f_{AV}				Edge distance in shear								Concrete thickness factor in shear f_{HV}			
													Toward edge f_{RV}				To edge f_{RV}							
Embedment in h_{ef} (mm)	5 (127)	11-1/4 (286)	15 (381)	20 (508)	5 (127)	11-1/4 (286)	15 (381)	20 (508)	5 (127)	11-1/4 (286)	15 (381)	20 (508)	5 (127)	11-1/4 (286)	15 (381)	20 (508)	5 (127)	11-1/4 (286)	15 (381)	20 (508)	5 (127)	11-1/4 (286)	15 (381)	20 (508)
1-3/4 (44)	n/a	n/a	n/a	n/a	0.38	0.22	0.16	0.12	n/a	n/a	n/a	n/a	0.05	0.02	0.01	0.01	0.11	0.04	0.03	0.02	n/a	n/a	n/a	n/a
6-1/4 (159)	0.63	0.59	0.57	0.55	0.66	0.33	0.24	0.18	0.59	0.54	0.54	0.53	0.37	0.13	0.10	0.07	0.66	0.26	0.19	0.15	n/a	n/a	n/a	n/a
7 (178)	0.65	0.60	0.58	0.56	0.70	0.35	0.26	0.19	0.60	0.55	0.54	0.53	0.43	0.15	0.11	0.09	0.70	0.31	0.23	0.17	n/a	n/a	n/a	n/a
8 (203)	0.67	0.62	0.59	0.57	0.76	0.38	0.28	0.21	0.61	0.55	0.54	0.54	0.53	0.19	0.14	0.11	0.76	0.37	0.28	0.21	0.66	n/a	n/a	n/a
9 (229)	0.69	0.63	0.60	0.58	0.82	0.41	0.30	0.22	0.62	0.56	0.55	0.54	0.63	0.22	0.17	0.13	0.82	0.41	0.30	0.22	0.70	n/a	n/a	n/a
10 (254)	0.71	0.65	0.61	0.58	0.88	0.44	0.33	0.24	0.64	0.57	0.56	0.55	0.74	0.26	0.20	0.15	0.88	0.44	0.33	0.24	0.74	n/a	n/a	n/a
11 (279)	0.73	0.66	0.62	0.59	0.94	0.48	0.35	0.26	0.65	0.57	0.56	0.55	0.86	0.30	0.23	0.17	0.94	0.48	0.35	0.26	0.78	n/a	n/a	n/a
12 (305)	0.75	0.68	0.63	0.60	1.00	0.51	0.38	0.28	0.66	0.58	0.57	0.56	0.98	0.34	0.26	0.19	1.00	0.51	0.38	0.28	0.81	n/a	n/a	n/a
13 (330)	0.77	0.69	0.64	0.61		0.55	0.41	0.30	0.68	0.59	0.57	0.56	1.00	0.39	0.29	0.22		0.55	0.41	0.30	0.84	n/a	n/a	n/a
14 (356)	0.80	0.71	0.66	0.62		0.60	0.44	0.32	0.69	0.60	0.58	0.56		0.43	0.32	0.24		0.60	0.44	0.32	0.87	0.62	n/a	n/a
14-1/4(362)	0.80	0.71	0.66	0.62		0.61	0.45	0.33	0.69	0.60	0.58	0.57		0.44	0.33	0.25		0.61	0.45	0.33	0.88	0.62	n/a	n/a
15 (381)	0.82	0.72	0.67	0.63		0.64	0.47	0.35	0.70	0.60	0.58	0.57		0.48	0.36	0.27		0.64	0.47	0.35	0.91	0.64	n/a	n/a
16 (406)	0.84	0.74	0.68	0.63		0.68	0.50	0.37	0.72	0.61	0.59	0.57		0.53	0.40	0.30		0.68	0.50	0.37	0.94	0.66	n/a	n/a
17 (432)	0.86	0.75	0.69	0.64		0.72	0.53	0.39	0.73	0.62	0.60	0.58		0.58	0.43	0.33		0.72	0.53	0.39	0.96	0.68	n/a	n/a
18 (457)	0.88	0.77	0.70	0.65		0.77	0.56	0.42	0.75	0.62	0.60	0.58		0.63	0.47	0.35		0.77	0.56	0.42	0.99	0.70	0.64	n/a
20 (508)	0.92	0.80	0.72	0.67		0.85	0.63	0.46	0.77	0.64	0.61	0.59		0.74	0.55	0.42		0.85	0.63	0.46	1.00	0.74	0.67	n/a
22 (559)	0.96	0.83	0.74	0.68		0.94	0.69	0.51	0.80	0.65	0.62	0.60		0.85	0.64	0.48		0.94	0.69	0.51		0.77	0.70	n/a
24 (610)	1.00	0.86	0.77	0.70		1.00	0.75	0.56	0.83	0.66	0.63	0.61		0.97	0.73	0.55		1.00	0.75	0.56		0.81	0.73	0.67
26 (660)		0.89	0.79	0.72			0.81	0.60	0.86	0.68	0.65	0.62		1.00	0.82	0.62			0.81	0.60		0.84	0.76	0.69
28 (711)		0.91	0.81	0.73			0.88	0.65	0.88	0.69	0.66	0.63			0.92	0.69			0.88	0.65		0.87	0.79	0.72
30 (762)		0.94	0.83	0.75			0.94	0.70	0.91	0.70	0.67	0.64			1.00	0.76			0.94	0.70		0.90	0.82	0.75
36 (914)		1.00	0.90	0.80			1.00	0.83	0.99	0.75	0.70	0.67				1.00			1.00	0.83		0.99	0.90	0.82
> 48 (1219)			1.00	0.90				1.00	1.00	0.83	0.77	0.72								1.00		1.00	1.00	0.94

¹ Linear interpolation not permitted

² Shaded area with reduced edge distance is permitted provided the installation torque is reduced to 0.30 T_{max} for 5d < s < 16-in. and to 0.5 T_{max} for s > 16-in.

³ When combining multiple load adjustment factors (e.g. for a four-anchor pattern in a corner with thin concrete member) the design can become very conservative. To optimize the design, perform anchor calculation using design equations from ACI 318 Chapter 17.

⁴ Spacing factor reduction in shear applicable when c < 3*h_{ef}. f_{AV} is applicable when edge distance, c < 3*h_{ef}. If c ≥ 3*h_{ef}, then f_{AV} = f_{AN}.

⁵ Concrete thickness reduction factor in shear, f_{HV}, is applicable when edge distance, c < 3*h_{ef}. If c ≥ 3*h_{ef}, then f_{HV} = 1.0.

CANADIAN LIMIT STATE DESIGN

Limit State Design of anchors is described in the provisions of CSA A23.3-14 Annex D for post-installed anchors tested and assessed in accordance with ACI 355.4 for adhesive anchors. This section contains the Limit State Design tables with unfactored characteristic loads that are based on testing and assessment in accordance with ACI 355.4. These tables are followed by factored resistance tables. The factored resistance tables have characteristic design loads that are prefactored by the applicable reduction factors for a single anchor with no anchor-to-anchor spacing or edge distance adjustments for the convenience of the user of this document. All the figures in the previous ACI 318-14 Chapter 17 design section are applicable to Limit State Design and the tables will reference these figures.

For a detailed explanation of the tables developed in accordance with CSA A23.3-14 Annex D, refer to Section 3.1.8 of the Hilti Product Technical Guide Volume 2 Ed. 17. Technical assistance is available by contacting Hilti Canada at (800) 363-4458 or at www.hilti.ca.

Table 25 - Specifications for Canadian rebar installed with HIT-RE 10 adhesive¹



Setting information	Symbol	Units	Nominal reinforcing bar size				
			10M	15M	20M	25M	30M
Nominal bit diameter	d_0	in.	9/16	3/4	1	1-1/4	1-3/8
Effective minimum embedment	$h_{ef,min}$	mm.	70	80	90	101	120
Effective maximum embedment	$h_{ef,max}$	mm.	226	320	390	500	500
Minimum concrete thickness	h_{min}	mm.	$h_{ef} + 30$	$h_{ef} + 2d_0$			

¹ See Figure 2 for installation information.

Table 26 - Hilti HIT-RE10 adhesive design information with CA rebar per CSA A23.3-14 Annex D¹



Design parameter	Symbol	Units	Rebar size					Ref A23.3-14	
			10M	15M	20M	25M	30M		
Anchor O.D.	d_0	mm	11.3	16.0	19.5	25.2	29.9		
Effective minimum embedment ¹	$h_{ef,min}$	mm	70	80	90	101	120		
Effective maximum embedment ¹	$h_{ef,max}$	mm	226	320	390	500	500		
Minimum concrete thickness ¹	h_{min}	mm	$h_{ef} + 30$	$h_{ef} + 2d_0$					
Critical edge distance	c_{ac}	mm	$c_{ac} = h_{ef} * \left(\frac{\tau_{k,uncr}}{8} \right)^{0.4} * \left[3.1 - 0.7 * \frac{h}{h_{ef}} \right]; \left(\frac{h}{h_{ef}} \right) \text{ need not be larger than } 2.4$ $\tau_{k,uncr} \text{ need not be taken as greater than: } \tau_{k,uncr} = \frac{k_{uncr} \sqrt{h_{ef} * f'_c}}{\pi * d_a}$						
Minimum edge distance	c_{min}^2	mm	57	80	98	126	150		
Minimum anchor spacing	s_{min}	mm	57	80	98	126	150		
Coefficient for factored concrete breakout resistance, uncracked concrete	$k_{c,uncr}^3$	-	10					D.6.2.2	
Concrete material resistance factor	ϕ_c	-	0.65					8.4.2	
Resistance modification factor for tension and shear, concrete failure modes, Condition B ⁴	R_{conc}	-	1.00					D.5.3 (c)	
Temp. range A ⁵	Characteristic bond stress in uncracked concrete ⁶	τ_{uncr}	psi (MPa)	1,201 (8.3)	1,172 (8.1)	1,150 (7.9)	1,115 (7.7)	1,086 (7.5)	D.6.5.2
Permissible installation conditions	Resistance modification factor tension & shear, bond failure dry concrete	Anchor category	-	2	2	2	2	2	D.5.3 (c)
		R_{dry}	-	0.85	0.85	0.85	0.85	0.85	
	Resistance modification factor tension & shear, bond failure water-saturated concrete	Anchor category	-	2	2	2	2	2	D.5.3 (c)
		R_{ws}	-	0.85	0.85	0.85	0.85	0.85	

¹ See figure 2.

² Minimum edge distance may be reduced to 45mm provided rebar remains untorqued.

³ For all design cases, $\psi_{c,N} = 1.0$. The appropriate coefficient for breakout resistance for cracked concrete ($k_{c,cr}$) or uncracked concrete ($k_{c,uncr}$) must be used.

⁴ For use with the load combinations of CSA A23.3-14 chapter 8. Condition B applies where supplementary reinforcement in conformance with CSA A23.3-14 section D.5.3 is not provided, or where pullout or pryout strength governs. For cases where the presence of supplementary reinforcement can be verified, the resistance modification factors associated with Condition A may be used.

⁵ Temperature range: Max. short term temperature = 130°F (55°C), maximum long term temperature = 110°F (43°C). Short term elevated concrete temperatures are those that occur over brief intervals, e.g., as a result of diurnal cycling. Long term concrete temperatures are roughly constant over significant periods of time.

⁶ Bond strength values corresponding to concrete compressive strength $f'_c = 2,500$ psi (17.2 MPa). For concrete compressive strength, f'_c , between 2,500 psi (17.2 MPa) and 8,000 psi (55.2 MPa), the tabulated characteristic bond strength may be increased by a factor of $(f'_c/2,500)^{0.26}$ [for SI: $(f'_c/17.2)^{0.26}$].

Table 27 - Hilti RE-10 adhesive factored resistance with concrete / bond failure for CA rebar in uncracked concrete ^{1,2,3,4,5,6,7,8}

Rebar size	Effective embedment in. (mm)	Tension - N_t				Shear - V_t			
		$f'_c = 20$ MPa (2,900 psi) lb (kN)	$f'_c = 25$ MPa (3,625 psi) lb (kN)	$f'_c = 30$ MPa (4,350 psi) lb (kN)	$f'_c = 40$ MPa (5,800 psi) lb (kN)	$f'_c = 20$ MPa (2,900 psi) lb (kN)	$f'_c = 20$ MPa (2,900 psi) lb (kN)	$f'_c = 20$ MPa (2,900 psi) lb (kN)	$f'_c = 40$ MPa (5,800 psi) lb (kN)
10M	4-1/2 (115)	3,580 (15.9)	3,795 (16.9)	3,975 (17.7)	4,285 (19.1)	7,160 (31.8)	7,585 (33.7)	7,955 (35.4)	8,570 (38.1)
	7-1/16 (180)	5,600 (24.9)	5,935 (26.4)	6,225 (27.7)	6,710 (29.8)	11,205 (49.8)	11,870 (52.8)	12,450 (55.4)	13,415 (59.7)
	8-7/8 (226)	7,035 (31.3)	7,455 (33.2)	7,815 (34.8)	8,420 (37.5)	14,065 (62.6)	14,905 (66.3)	15,630 (69.5)	16,845 (74.9)
15M	5-11/16 (145)	6,265 (27.9)	6,640 (29.5)	6,960 (31.0)	7,505 (33.4)	12,530 (55.7)	13,280 (59.1)	13,925 (61.9)	15,005 (66.8)
	9-13/16 (250)	10,805 (48.1)	11,450 (50.9)	12,005 (53.4)	12,935 (57.5)	21,605 (96.1)	22,895 (101.8)	24,010 (106.8)	25,875 (115.1)
	12-5/8 (320)	13,830 (61.5)	14,655 (65.2)	15,365 (68.3)	16,560 (73.7)	27,655 (123.0)	29,310 (130.4)	30,730 (136.7)	33,115 (147.3)
20M	7-7/8 (200)	10,380 (46.2)	11,000 (48.9)	11,535 (51.3)	12,430 (55.3)	20,760 (92.3)	22,000 (97.9)	23,070 (102.6)	24,860 (110.6)
	14 (355)	18,425 (82.0)	19,525 (86.9)	20,475 (91.1)	22,065 (98.1)	36,850 (163.9)	39,050 (173.7)	40,945 (182.1)	44,125 (196.3)
	15-3/8 (390)	20,240 (90.0)	21,450 (95.4)	22,490 (100.0)	24,240 (107.8)	40,485 (180.1)	42,900 (190.8)	44,985 (200.1)	48,475 (215.6)
25M	9-1/16 (230)	15,055 (67.0)	15,955 (71.0)	16,725 (74.4)	18,025 (80.2)	30,105 (133.9)	31,905 (141.9)	33,455 (148.8)	36,050 (160.4)
	15-15/16 (405)	26,505 (117.9)	28,090 (125.0)	29,455 (131.0)	31,740 (141.2)	53,015 (235.8)	56,180 (249.9)	58,910 (262.0)	63,485 (282.4)
	19-11/16 (500)	32,725 (145.6)	34,680 (154.3)	36,365 (161.8)	39,185 (174.3)	65,450 (291.1)	69,360 (308.5)	72,725 (323.5)	78,375 (348.6)
30M	10-1/4 (260)	19,775 (88.0)	20,960 (93.2)	21,975 (97.8)	23,685 (105.3)	39,555 (175.9)	41,915 (186.5)	43,950 (195.5)	47,365 (210.7)
	17-15/16 (455)	34,610 (154.0)	36,680 (163.2)	38,460 (171.1)	41,445 (184.4)	69,220 (307.9)	73,355 (326.3)	76,915 (342.1)	82,890 (368.7)
	19-11/16 (500)	38,035 (169.2)	40,305 (179.3)	42,260 (188.0)	45,545 (202.6)	76,065 (338.4)	80,610 (358.6)	84,525 (376.0)	91,090 (405.2)

¹ See Section 3.1.8 of Hilti Product Technical Guide 17 Volume 2 for explanation on development of load values.

² See Section 3.1.8.6 of Hilti Product Technical Guide 17 Volume 2 to convert design strength value to ASD value.

³ Linear interpolation between embedment depths and concrete compressive strengths is not permitted.

⁴ Apply spacing, edge distance, and concrete thickness factors in tables 29 - 33 as necessary. Compare to the steel values in table 28. The lesser of the values is to be used for the design.

⁵ Max. short term temperature = 130°F (55°C), maximum long term temperature = 110°F (43°C). Short term elevated concrete temperatures are those that occur over brief intervals, e.g., as a result of diurnal cycling. Long term concrete temperatures are roughly constant over significant periods of time.

⁶ Tabular values are for dry concrete and water saturated concrete

⁷ Tabular values are for short term loads only. For sustained loads including overhead use, see Section 3.1.8.8 of Hilti Product Technical Guide 17 Volume 2.

⁸ Tabular values are for normal-weight concrete only. For lightweight concrete multiply design strength by λ_s as follows:

For sand-lightweight, $\lambda_s = 0.51$. For all-lightweight, $\lambda_s = 0.45$.

Table 28 - Steel factored resistance for CA rebar ¹

Rebar size	CSA-G30.18 Grade 40 ²	
	Tensile ³ N_{sar} lb (kN)	Shear ⁴ V_{sar} lb (kN)
10M	7,245 (32.2)	4,035 (17.9)
15M	14,525 (64.6)	8,090 (36.0)
20M	21,570 (95.9)	12,020 (53.5)
25M	36,025 (160.2)	20,070 (89.3)
30M	50,715 (225.6)	28,255 (125.7)

¹ See Section 3.1.8.6 to convert design strength value to ASD value.

² CSA-G30.18 Grade 400 rebar are considered ductile steel elements.

³ Tensile = $A_{se,N} \phi_s f_{da} R$ as noted in CSA A23.3-14 Annex D

⁴ Shear = $A_{se,V} \phi_s 0.60 f_{da} R$ as noted in CSA A23.3-14 Annex D.



Table 29 - Load adjustment factors for 10M rebar in uncracked concrete ^{1,2,3}

10M uncracked concrete	Spacing factor in tension			Edge distance factor in tension			Spacing factor in shear ⁴			Edge distance in shear						Concrete thickness factor in shear ⁵		
	f_{AN}			f_{RN}			f_{AV}			⊥ Toward edge f_{RV}			∥ To edge f_{RV}			f_{HV}		
Embedment in h_{ef} (mm)	4-1/2 (115)	7-1/16 (180)	8-7/8 (226)	4-1/2 (115)	7-1/16 (180)	8-7/8 (226)	4-1/2 (115)	7-1/16 (180)	8-9/9 (226)	4-1/2 (115)	7-1/16 (180)	8-7/8 (226)	4-1/2 (115)	7-1/16 (180)	8-7/8 (226)	4-1/2 (115)	7-1/16 (180)	8-7/8 (226)
1-3/4 (44)	n/a	n/a	n/a	0.24	0.15	0.12	n/a	n/a	n/a	0.10	0.06	0.05	0.19	0.12	0.10	n/a	n/a	n/a
2-3/16 (55)	0.58	0.55	0.54	0.27	0.17	0.13	0.54	0.53	0.53	0.13	0.08	0.07	0.26	0.17	0.13	n/a	n/a	n/a
3 (76)	0.61	0.57	0.56	0.32	0.20	0.16	0.56	0.54	0.54	0.22	0.14	0.11	0.32	0.20	0.16	n/a	n/a	n/a
4 (102)	0.65	0.59	0.57	0.39	0.24	0.19	0.58	0.56	0.55	0.33	0.21	0.17	0.39	0.24	0.19	n/a	n/a	n/a
5 (127)	0.68	0.62	0.59	0.48	0.30	0.24	0.60	0.57	0.56	0.47	0.30	0.24	0.48	0.30	0.24	n/a	n/a	n/a
5-11/16 (145)	0.71	0.63	0.61	0.55	0.34	0.27	0.61	0.58	0.57	0.57	0.36	0.29	0.55	0.34	0.27	0.68	n/a	n/a
6 (152)	0.72	0.64	0.61	0.58	0.36	0.28	0.62	0.59	0.58	0.61	0.39	0.31	0.58	0.36	0.28	0.69	n/a	n/a
7 (178)	0.76	0.66	0.63	0.67	0.42	0.33	0.64	0.60	0.59	0.77	0.49	0.39	0.67	0.42	0.33	0.75	n/a	n/a
8 (203)	0.79	0.69	0.65	0.77	0.48	0.38	0.66	0.62	0.60	0.94	0.60	0.48	0.77	0.48	0.38	0.80	n/a	n/a
8-1/4 (210)	0.80	0.69	0.65	0.79	0.49	0.39	0.67	0.62	0.61	0.99	0.63	0.50	0.79	0.49	0.39	0.81	0.70	n/a
10-1/16 (256)	0.87	0.74	0.69	0.97	0.60	0.47	0.70	0.65	0.63	1.00	0.85	0.68	0.97	0.60	0.47	0.90	0.77	0.72
12 (305)	0.94	0.78	0.72	1.00	0.72	0.56	0.74	0.68	0.65		1.00	0.88	1.00	0.72	0.56	0.98	0.84	0.78
14 (356)	1.00	0.83	0.76		0.83	0.66	0.78	0.71	0.68			1.00		0.83	0.66	1.00	0.91	0.85
16 (406)		0.88	0.80		0.95	0.75	0.82	0.74	0.70					0.95	0.75		0.98	0.90
18 (457)		0.92	0.84		1.00	0.85	0.86	0.77	0.73					1.00	0.85		1.00	0.96
24 (610)		1.00	0.95			1.00	0.98	0.86	0.81						1.00			1.00
30 (762)			1.00				1.00	0.95	0.88									
36 (914)								1.00	0.96									
> 48 (1219)									1.00									

¹ Linear interpolation not permitted

² Shaded area with reduced edge distance is permitted provided the rebar has no installation torque.

³ When combining multiple load adjustment factors (e.g. for a four-anchor pattern in a corner with thin concrete member) the design can become very conservative. To optimize the design, perform anchor calculation using design equations from CSA A23.3-14 Annex D.

⁴ Spacing factor reduction in shear applicable when $c < 3 \cdot h_{ef}$. f_{AV} is applicable when edge distance, $c < 3 \cdot h_{ef}$. If $c \geq 3 \cdot h_{ef}$, then $f_{AV} = f_{AN}$.

⁵ Concrete thickness reduction factor in shear, f_{HV} , is applicable when edge distance, $c < 3 \cdot h_{ef}$. If $c \geq 3 \cdot h_{ef}$, then $f_{HV} = 1.0$.

Table 30 - Load adjustment factors for 15M rebar in uncracked concrete ^{1,2,3}



15M uncracked concrete	Spacing factor in tension			Edge distance factor in tension			Spacing factor in shear ⁴			Edge distance in shear						Concrete thickness factor in shear ⁵		
	f_{AN}			f_{RN}			f_{AV}			⊥ Toward edge f_{RV}			∥ To edge f_{RV}			f_{HV}		
Embedment in h_{ef} (mm)	5-11/16 (145)	9-13/16 (250)	12-5/8 (320)	5-11/16 (145)	9-13/16 (250)	12-5/8 (320)	5-11/16 (145)	9-13/16 (250)	12-5/8 (320)	5-11/16 (145)	9-13/16 (250)	12-5/8 (320)	5-11/16 (145)	9-13/16 (250)	12-5/8 (320)	5-11/16 (145)	9-13/16 (250)	12-5/8 (320)
1-3/4 (44)	n/a	n/a	n/a	0.22	0.13	0.10	n/a	n/a	n/a	0.07	0.04	0.03	0.13	0.08	0.06	n/a	n/a	n/a
3-1/8 (80)	0.59	0.55	0.54	0.29	0.16	0.12	0.55	0.53	0.53	0.16	0.09	0.07	0.29	0.16	0.12	n/a	n/a	n/a
4 (102)	0.62	0.57	0.55	0.33	0.18	0.14	0.56	0.54	0.54	0.23	0.13	0.10	0.33	0.18	0.14	n/a	n/a	n/a
5 (127)	0.65	0.58	0.57	0.38	0.21	0.16	0.58	0.55	0.55	0.31	0.18	0.14	0.38	0.21	0.16	n/a	n/a	n/a
6 (152)	0.68	0.60	0.58	0.43	0.24	0.19	0.59	0.56	0.55	0.41	0.24	0.19	0.43	0.24	0.19	n/a	n/a	n/a
7 (178)	0.70	0.62	0.59	0.50	0.28	0.22	0.61	0.58	0.56	0.52	0.30	0.24	0.50	0.28	0.22	n/a	n/a	n/a
7-1/4 (184)	0.71	0.62	0.60	0.52	0.29	0.23	0.61	0.58	0.57	0.55	0.32	0.25	0.52	0.29	0.23	0.67	n/a	n/a
8 (203)	0.73	0.64	0.61	0.57	0.32	0.25	0.62	0.59	0.57	0.64	0.37	0.29	0.57	0.32	0.25	0.70	n/a	n/a
10 (254)	0.79	0.67	0.63	0.72	0.40	0.31	0.65	0.61	0.59	0.89	0.52	0.40	0.72	0.40	0.31	0.79	n/a	n/a
11-3/8 (289)	0.83	0.69	0.65	0.82	0.46	0.35	0.68	0.62	0.60	1.00	0.63	0.49	0.82	0.46	0.35	0.84	0.70	n/a
12 (305)	0.85	0.70	0.66	0.86	0.48	0.37	0.69	0.63	0.61		0.68	0.53	0.86	0.48	0.37	0.86	0.72	n/a
14-1/8 (359)	0.91	0.74	0.69	1.00	0.57	0.44	0.72	0.65	0.63		0.87	0.68	1.00	0.57	0.44	0.93	0.78	0.72
16 (406)	0.97	0.77	0.71		0.64	0.50	0.75	0.67	0.65		1.00	0.82		0.64	0.50	0.99	0.83	0.76
18 (457)	1.00	0.80	0.74		0.72	0.56	0.78	0.69	0.66			0.97		0.72	0.56	1.00	0.88	0.81
20 (508)		0.84	0.76		0.81	0.62	0.81	0.71	0.68			1.00		0.81	0.62		0.93	0.85
22 (559)		0.87	0.79		0.89	0.69	0.84	0.74	0.70					0.89	0.69		0.97	0.89
24 (610)		0.91	0.82		0.97	0.75	0.87	0.76	0.72					0.97	0.75		1.00	0.93
30 (762)			1.00		1.00	0.93	0.96	0.82	0.77					1.00	0.93			1.00
36 (914)					0.98	1.00	1.00	0.89	0.83						1.00			
> 48 (1219)			1.00					1.00	0.94									

¹ Linear interpolation not permitted

² Shaded area with reduced edge distance is permitted provided the rebar has no installation torque.

³ When combining multiple load adjustment factors (e.g. for a four-anchor pattern in a corner with thin concrete member) the design can become very conservative. To optimize the design, perform anchor calculation using design equations from CSA A23.3-14 Annex D.

⁴ Spacing factor reduction in shear applicable when $c < 3 \cdot h_{ef}$. f_{AV} is applicable when edge distance, $c < 3 \cdot h_{ef}$. If $c \geq 3 \cdot h_{ef}$, then $f_{AV} = f_{AN}$.

⁵ Concrete thickness reduction factor in shear, f_{HV} , is applicable when edge distance, $c < 3 \cdot h_{ef}$. If $c \geq 3 \cdot h_{ef}$, then $f_{HV} = 1.0$.



Table 33 - Load adjustment factors for 30M rebar in uncracked concrete ^{1,2,3}

30M uncracked concrete	Spacing factor in tension f_{AN}			Edge distance factor in tension f_{RN}			Spacing factor in shear ⁴ f_{AV}			Edge distance in shear						Concrete thickness factor in shear ⁵ f_{HV}			
										⊥ Toward edge f_{RV}			∥ To edge f_{RV}						
	Embedment in h_{ef} (mm)	10-1/4 (260)	17-5/16 (455)	19-11/16 (500)	10-1/4 (260)	17-5/16 (455)	19-11/16 (500)	10-1/4 (260)	17-5/16 (455)	19-11/16 (500)	10-1/4 (260)	17-5/16 (455)	19-11/16 (500)	10-1/4 (260)	17-5/16 (455)	19-11/16 (500)	10-1/4 (260)	17-5/16 (455)	19-11/16 (500)
Spacing (s) / edge distance (ca) / concrete thickness (h _c) - in (mm)	1-3/4 (44)	n/a	n/a	n/a	0.23	0.13	0.11	n/a	n/a	n/a	0.03	0.02	0.01	0.05	0.03	0.03	n/a	n/a	n/a
	5-7/8 (150)	0.60	0.55	0.55	0.35	0.19	0.17	0.55	0.53	0.53	0.17	0.09	0.09	0.33	0.19	0.17	n/a	n/a	n/a
	6 (152)	0.60	0.56	0.55	0.35	0.19	0.17	0.55	0.54	0.53	0.17	0.10	0.09	0.34	0.19	0.17	n/a	n/a	n/a
	7 (178)	0.61	0.57	0.56	0.38	0.21	0.19	0.56	0.54	0.54	0.21	0.12	0.11	0.38	0.21	0.19	n/a	n/a	n/a
	8 (203)	0.63	0.57	0.57	0.42	0.23	0.21	0.57	0.55	0.54	0.26	0.15	0.14	0.42	0.23	0.21	n/a	n/a	n/a
	9 (229)	0.65	0.58	0.58	0.45	0.25	0.22	0.58	0.55	0.55	0.31	0.18	0.16	0.45	0.25	0.22	n/a	n/a	n/a
	10 (254)	0.66	0.59	0.58	0.49	0.27	0.24	0.59	0.56	0.56	0.37	0.21	0.19	0.49	0.27	0.24	n/a	n/a	n/a
	11 (279)	0.68	0.60	0.59	0.52	0.29	0.26	0.59	0.56	0.56	0.42	0.24	0.22	0.52	0.29	0.26	n/a	n/a	n/a
	12 (305)	0.70	0.61	0.60	0.57	0.31	0.28	0.60	0.57	0.57	0.48	0.27	0.25	0.57	0.31	0.28	n/a	n/a	n/a
	13-1/4 (337)	0.72	0.62	0.61	0.63	0.35	0.31	0.61	0.58	0.57	0.56	0.32	0.29	0.63	0.35	0.31	0.67	n/a	n/a
	14 (356)	0.73	0.63	0.62	0.66	0.36	0.33	0.62	0.58	0.58	0.60	0.35	0.31	0.66	0.36	0.33	0.69	n/a	n/a
	16 (406)	0.76	0.65	0.64	0.76	0.42	0.38	0.64	0.59	0.59	0.74	0.42	0.38	0.76	0.42	0.38	0.74	n/a	n/a
	18 (457)	0.79	0.67	0.65	0.85	0.47	0.42	0.65	0.61	0.60	0.88	0.50	0.46	0.85	0.47	0.42	0.78	n/a	n/a
	20 (508)	0.83	0.69	0.67	0.95	0.52	0.47	0.67	0.62	0.61	1.00	0.59	0.54	0.95	0.52	0.47	0.83	n/a	n/a
	20-7/8 (531)	0.84	0.69	0.68	0.99	0.54	0.49	0.68	0.62	0.62		0.63	0.57	0.99	0.54	0.49	0.84	n/a	n/a
	22 (559)	0.86	0.70	0.69	1.00	0.57	0.52	0.69	0.63	0.62		0.68	0.62	1.00	0.57	0.52	0.87	0.72	n/a
	24 (610)	0.89	0.72	0.70		0.63	0.57	0.70	0.64	0.63		0.78	0.71		0.63	0.57	0.90	0.75	0.73
	26-9/16 (675)	0.93	0.75	0.73		0.69	0.63	0.73	0.66	0.65		0.90	0.82		0.69	0.63	0.95	0.79	0.77
	28 (711)	0.96	0.76	0.74		0.73	0.66	0.74	0.66	0.65		0.98	0.89		0.73	0.66	0.98	0.81	0.79
30 (762)	0.99	0.78	0.75		0.78	0.71	0.76	0.68	0.67		1.00	0.99		0.78	0.71	1.00	0.84	0.81	
36 (914)	1.00	0.83	0.80		0.94	0.85	0.81	0.71	0.70			1.00		0.94	0.85		0.92	0.89	
> 48 (1219)		0.95	0.91		1.00	1.00	0.91	0.78	0.76					1.00	1.00		1.00	1.00	

¹ Linear interpolation not permitted

² Shaded area with reduced edge distance is permitted provided the rebar has no installation torque.

³ When combining multiple load adjustment factors (e.g. for a four-anchor pattern in a corner with thin concrete member) the design can become very conservative. To optimize the design, perform anchor calculation using design equations from CSA A23.3-14 Annex D.

⁴ Spacing factor reduction in shear applicable when $c < 3 \cdot h_{ef}$. f_{AV} is applicable when edge distance, $c < 3 \cdot h_{ef}$. If $c \geq 3 \cdot h_{ef}$, then $f_{AV} = f_{AN}$.

⁵ Concrete thickness reduction factor in shear, f_{HV} , is applicable when edge distance, $c < 3 \cdot h_{ef}$. If $c \geq 3 \cdot h_{ef}$, then $f_{HV} = 1.0$.

Table 34 - Hilti HIT-RE 10 design information with HAS threaded rods per CSA A23.3-14 Annex D

Design parameter	Symbol	Units	Nominal rod diameter (in.)							Ref A23.3- 14
			3/8	1/2	5/8	3/4	7/8	1	1-1/4	
Nominal anchor diameter	d_a	mm	9.5	12.7	15.9	19.1	22.2	25.4	31.8	
Effective minimum embedment ²	$h_{ef,min}$	mm	60	70	80	89	89	102	127	
Effective maximum embedment ²	$h_{ef,max}$	mm	191	254	318	381	445	500	500	
Minimum concrete thickness ²	h_{min}	mm	$h_{ef} + 30 > 100$		$h_{ef} + 2d_0^{(6)}$					
Critical edge distance	c_{ac}	mm	$c_{ac} = h_{ef} * \left(\frac{\tau_{k,uncr}}{8}\right)^{0.4} * \left[3.1 - 0.7 * \frac{h}{h_{ef}}\right]; \left(\frac{h}{h_{ef}}\right)$ need not be larger than 2.4 $\tau_{k,uncr}$ need not be taken as greater than: $\tau_{k,uncr} = \frac{k_{uncr} \sqrt{h_{hef} * f'_c}}{\pi * d_a}$							
Minimum edge distance	c_{min}^3	mm	48	64	79	95	111	127	159	
Minimum anchor spacing	s_{min}	mm	48	64	79	95	111	127	159	
Coefficient for factored concrete breakout resistance, uncracked concrete	$k_{c,uncr}^4$	-	10							D.6.2.2
Concrete material resistance factor	ϕ_c	-	0.65							8.4.2
Resistance modification factor for tension and shear, concrete failure modes, Condition B ⁵	R_{conc}	Psi (N/mn ²)	1.00							D.5.3
Characteristic bond stress in uncracked concrete ^{6,7}	τ_{uncr}	Psi (MPa)	1,246 (8.6)	1,191 (8.2)	1,136 (7.8)	1,082 (7.5)	1,029 (7.1)	974 (6.7)	864 (6.0)	D.6.5.2
Anchor category, dry concrete	-	-	2	2	3	3	3	3	3	
Resistance modification factor	R_{dry}	-	0.85	0.85	0.75	0.75	0.75	0.75	0.75	
Anchor category, water saturated concrete	-	-	2	2	3	3	3	3	3	
Resistance modification factor	R_{wf}	-	0.85	0.85	0.75	0.75	0.75	0.75	0.75	

¹ Design information in this table is based on testing in accordance with ACI 355.4.

² See figure 4 of this section.

³ Minimum edge distance may be reduced to 45mm < c_{min} < 5d provided T_{inst} is reduced.

⁴ For all design cases, $\psi_{c,N} = 1.0$.

⁵ For use with the load combinations of CSA A23.3-14 chapter 8. Condition B applies where supplementary reinforcement in conformance with CSA A23.3-14 section D.5.3 is not provided, or where pullout or pryout strength governs. For cases where the presence of supplementary reinforcement can be verified, the resistance modification factors associated with Condition A may be used. Condition B applies where supplementary reinforcement in conformance with CSA A23.3-14 section D.5.3 is not provided, or where pullout or pryout strength governs.

For cases where the presence of supplementary reinforcement can be verified, the reduction factors associated with Condition A may be used.

⁶ Max. short term temperature = 55°C, maximum long term temperature = 43°C.

Short term elevated concrete temperatures are those that occur over brief intervals, e.g., as a result of diurnal cycling. Long term concrete temperatures are roughly constant over significant periods of time.

⁷ Bond strength values corresponding to concrete compressive strength $f'_c = 17.2$ MPa. For concrete compressive strength, f'_c , between 17.2 MPa and 55.2 MPa, the tabulated characteristic bond strength may be increased by a factor of $(f'_c/17.2)^{0.15}$
⁶ d_0 = drilled hole diameter, see figure 4.



Table 35 - Hilti HIT-RE 10 adhesive factored resistance with concrete / bond failure for threaded rod in uncracked concrete ^{1,2,3,4,5,6,7,8}

Nominal anchor diameter in.	Effective embedment in. (mm)	Tension - ΦN_n				Shear - ΦV_n			
		$f'_c = 20 \text{ MPa}$ (2,900 psi) lb (kN)	$f'_c = 25 \text{ MPa}$ (3,625 psi) lb (kN)	$f'_c = 30 \text{ MPa}$ (4,350 psi) lb (kN)	$f'_c = 40 \text{ MPa}$ (5,800 psi) lb (kN)	$f'_c = 20 \text{ MPa}$ (2,900 psi) lb (kN)	$f'_c = 25 \text{ MPa}$ (3,625 psi) lb (kN)	$f'_c = 30 \text{ MPa}$ (4,350 psi) lb (kN)	$f'_c = 40 \text{ MPa}$ (5,800 psi) lb (kN)
3/8	2-3/8 (60)	1,955 (8.7)	2,000 (8.9)	2,035 (9.1)	2,095 (9.3)	1,955 (8.7)	2,000 (8.9)	2,035 (9.1)	2,095 (9.3)
	3-3/8 (86)	2,780 (12.4)	2,840 (12.6)	2,895 (12.9)	2,980 (13.3)	5,560 (24.7)	5,685 (25.3)	5,790 (25.8)	5,960 (26.5)
	4-1/2 (114)	3,705 (16.5)	3,790 (16.9)	3,860 (17.2)	3,970 (17.7)	7,410 (33.0)	7,580 (33.7)	7,720 (34.3)	7,945 (35.3)
	7-1/2 (191)	6,175 (27.5)	6,315 (28.1)	6,430 (28.6)	6,620 (29.4)	12,355 (55.0)	12,630 (56.2)	12,865 (57.2)	13,240 (58.9)
1/2	2-3/4 (70)	2,885 (12.8)	2,950 (13.1)	3,005 (13.4)	3,095 (13.8)	5,775 (25.7)	5,905 (26.3)	6,010 (26.7)	6,185 (27.5)
	4-1/2 (114)	4,725 (21.0)	4,830 (21.5)	4,920 (21.9)	5,060 (22.5)	9,445 (42.0)	9,660 (43.0)	9,835 (43.8)	10,125 (45.0)
	6 (152)	6,300 (28.0)	6,440 (28.6)	6,560 (29.2)	6,750 (30.0)	12,595 (56.0)	12,880 (57.3)	13,115 (58.3)	13,500 (60.0)
	10 (254)	10,495 (46.7)	10,735 (47.7)	10,930 (48.6)	11,250 (50.0)	20,990 (93.4)	21,465 (95.5)	21,860 (97.2)	22,500 (100.1)
5/8	3-1/8 (79)	3,600 (16.0)	3,680 (16.4)	3,750 (16.7)	3,860 (17.2)	7,200 (32.0)	7,360 (32.7)	7,495 (33.3)	7,715 (34.3)
	5-5/8 (143)	6,480 (28.8)	6,625 (29.5)	6,745 (30.0)	6,945 (30.9)	12,960 (57.6)	13,250 (58.9)	13,495 (60.0)	13,890 (61.8)
	7-1/2 (191)	8,640 (38.4)	8,835 (39.3)	8,995 (40.0)	9,260 (41.2)	17,275 (76.9)	17,665 (78.6)	17,990 (80.0)	18,515 (82.4)
	12-1/2 (318)	14,400 (64.0)	14,725 (65.5)	14,995 (66.7)	15,430 (68.6)	28,795 (128.1)	29,445 (131.0)	29,985 (133.4)	30,860 (137.3)
3/4	3-1/2 (89)	4,390 (19.5)	4,490 (20.0)	4,570 (20.3)	4,705 (20.9)	8,775 (39.0)	8,975 (39.9)	9,140 (40.7)	9,405 (41.8)
	6-3/4 (171)	8,465 (37.6)	8,655 (38.5)	8,815 (39.2)	9,070 (40.4)	16,930 (75.3)	17,310 (77.0)	17,630 (78.4)	18,140 (80.7)
	9 (229)	11,285 (50.2)	11,540 (51.3)	11,750 (52.3)	12,095 (53.8)	22,570 (100.4)	23,080 (102.7)	23,505 (104.6)	24,190 (107.6)
	15 (381)	18,810 (83.7)	19,235 (85.6)	19,585 (87.1)	20,160 (89.7)	37,615 (167.3)	38,465 (171.1)	39,175 (174.3)	40,315 (179.3)
7/8	3-1/2 (89)	5,050 (22.5)	5,165 (23.0)	5,260 (23.4)	5,410 (24.1)	10,095 (44.9)	10,325 (45.9)	10,515 (46.8)	10,820 (48.1)
	7-7/8 (200)	11,360 (50.5)	11,615 (51.7)	11,830 (52.6)	12,175 (54.2)	22,720 (101.1)	23,230 (103.3)	23,660 (105.2)	24,350 (108.3)
	10-1/2 (267)	15,145 (67.4)	15,490 (68.9)	15,775 (70.2)	16,235 (72.2)	30,290 (134.7)	30,975 (137.8)	31,545 (140.3)	32,465 (144.4)
	17-1/2 (445)	25,245 (112.3)	25,815 (114.8)	26,290 (116.9)	27,055 (120.3)	50,485 (224.6)	51,625 (229.6)	52,575 (233.9)	54,110 (240.7)
1	4 (102)	6,530 (29.1)	6,680 (29.7)	6,800 (30.3)	7,000 (31.1)	13,065 (58.1)	13,360 (59.4)	13,605 (60.5)	14,000 (62.3)
	9 (229)	14,695 (65.4)	15,030 (66.8)	15,305 (68.1)	15,750 (70.1)	29,395 (130.7)	30,055 (133.7)	30,610 (136.2)	31,505 (140.1)
	12 (305)	19,595 (87.2)	20,040 (89.1)	20,405 (90.8)	21,000 (93.4)	39,190 (174.3)	40,075 (178.3)	40,815 (181.5)	42,005 (186.8)
	20 (508)	32,660 (145.3)	33,395 (148.6)	34,010 (151.3)	35,005 (155.7)	65,320 (290.6)	66,795 (297.1)	68,020 (302.6)	70,005 (311.4)
1-1/4	5 (127)	9,355 (41.6)	10,140 (45.1)	10,325 (45.9)	10,625 (47.3)	18,705 (83.2)	20,275 (90.2)	20,650 (91.9)	21,250 (94.5)
	11-1/4 (286)	22,310 (99.2)	22,810 (101.5)	23,230 (103.3)	23,910 (106.4)	44,615 (198.5)	45,620 (202.9)	46,460 (206.7)	47,815 (212.7)
	15 (381)	29,745 (132.3)	30,415 (135.3)	30,975 (137.8)	31,880 (141.8)	59,485 (264.6)	60,830 (270.6)	61,950 (275.6)	63,755 (283.6)
	20 (508)	39,660 (176.4)	40,555 (180.4)	41,300 (183.7)	42,505 (189.1)	79,315 (352.8)	81,105 (360.8)	82,600 (367.4)	85,010 (378.1)

¹ See Section 3.1.8 of Hilti Product Technical Guide-17 Volume 2 for explanation on development of load values.
² See Section 3.1.8.6 of Hilti Product Technical Guide-17 Volume 2 to convert design strength value to ASD value.
³ Linear interpolation between embedment depths and concrete compressive strengths is not permitted.
⁴ Apply spacing, edge distance, and concrete thickness factors in tables 18-24 as necessary. Compare to the steel values in table 36. The lesser of the values is to be used for the design.
⁵ Max. short term temperature = 130°F (55°C), maximum long term temperature = 110°F (43°C). Short term elevated concrete temperatures are those that occur over brief intervals, e.g., as a result of diurnal cycling. Long term concrete temperatures are roughly constant over significant periods of time.
⁶ Tabular values are for dry concrete and water saturated concrete.
⁷ Tabular values are for short term loads only. For sustained loads including overhead use, see Section 3.1.8.8 of Hilti Product Technical Guide - 17 Volume 2.
⁸ Tabular values are for normal-weight concrete only. For lightweight concrete multiply design strength by λ_s as follows:
 For sand-lightweight, $\lambda_s = 0.51$. For all-lightweight, $\lambda_s = 0.45$.

Table 36 - Steel factored resistance for Hilti HAS threaded rods for use with CSA A23.3-14 Annex D

Nominal anchor diameter in.	HAS-V-36 / HAS-V-36 HDG ASTM F1554 Gr. 36 ^{3,5}		HAS-E-55 / HAS-E-55 HDG ASTM F1554 Gr. 55 ^{3,5}		HAS-B-105 / HAS-B-105 HDG ASTM A193 B7 and ASTM F 1554 Gr. 105 ^{3,5}		HAS-R Stainless Steel ASTM F593 (3/8-in to 1-in) ⁴ ASTM A193 (1-1/4-in) ³	
	Tensile ¹ N _{sar} lb (kN)	Shear ² V _{sar} lb (kN)	Tensile ¹ N _{sar} lb (kN)	Shear ² V _{sar} lb (kN)	Tensile ¹ N _{sar} lb (kN)	Shear ² V _{sar} lb (kN)	Tensile ¹ N _{sar} lb (kN)	Shear ² V _{sar} lb (kN)
3/8	3,055 (13.6)	1,720 (7.7)	3,955 (17.6)	2,225 (9.9)	6,570 (29.2)	3,695 (16.4)	4,610 (20.5)	2,570 (11.4)
1/2	5,595 (24.9)	3,150 (14.0)	7,240 (32.2)	4,070 (18.1)	12,035 (53.5)	6,765 (30.1)	8,445 (37.6)	4,705 (20.9)
5/8	8,915 (39.7)	5,015 (22.3)	11,525 (51.3)	6,485 (28.8)	19,160 (85.2)	10,780 (48.0)	13,445 (59.8)	7,490 (33.3)
3/4	13,190 (58.7)	7,420 (33.0)	17,060 (75.9)	9,600 (42.7)	28,365 (126.2)	15,955 (71.0)	16,920 (75.3)	9,425 (41.9)
7/8	18,210 (81.0)	10,245 (45.6)	23,550 (104.8)	13,245 (58.9)	39,150 (174.1)	22,020 (97.9)	23,350 (103.9)	13,010 (57.9)
1	23,890 (106.3)	13,440 (59.8)	30,890 (137.4)	17,380 (77.3)	51,360 (228.5)	28,890 (128.5)	30,635 (136.3)	17,065 (75.9)
1-1/4	38,225 (170.0)	21,500 (95.6)	49,425 (219.9)	27,800 (123.7)	82,175 (365.5)	46,220 (205.6)	37,565 (167.1)	21,130 (94.0)

¹ Tensile = $A_{se} N \phi_s f_{uta} R$ as noted in CSA A23.3-14 Eq. D.2.

² Shear = $A_{se} V \phi_s 0.60 f_{uta} R$ as noted in CSA A23.3-14 Eq. D.31.

³ HAS-V, HAS-E (3/8-in to 1-1/4-in), HAS-B, and HAS-R (Class 1; 1-1/4-in) threaded rods are considered ductile steel elements (including HDG rods).







⁴ HAS-R (CW1 and CW2; 3/8-in to 1-in) threaded rods are considered brittle steel elements (including HDG rods).

⁵ 3/8-inch dia. threaded rods are not included in the ASTM F1554 standard. Hilti 3/8-inch dia. HAS-V, HAS-E, and HAS-B (incl. HDG) threaded rods meet the chemical composition and mechanical property requirements of ASTM F1554.

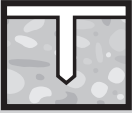
INSTALLATION INSTRUCTIONS

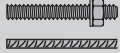
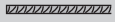
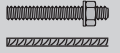
Installation Instructions For Use (IFU) are included with each product package. They can also be viewed or downloaded online at www.hilti.com (US) and www.hilti.ca (Canada). Because of the possibility of changes, always verify that downloaded IFU are current when used. Proper installation is critical to achieve full performance. Training is available on request. Contact Hilti Technical Services for applications and conditions not addressed in the IFU.

Figure 6 – HIT-RE 10 adhesive cure and working time (approx.)

					
	[°F]	[°C]	 t_{work}	 $t_{cure,ini}$	 $t_{cure,full}$
	41 ... 50	5 ... 10	5 h	30 h	72 h
	>50 ... 68	>10 ... 15	2.5 h	20 h	48 h
	>59 ... 68	>15 ... 20	2 h	15 h	36 h
	>68 ... 86	>20 ... 30	60 min	10 h	24 h
	>86 ... 104	>30 ... 40	30 min	5 h	12 h

 = 2x t_{cure}

ORDERING INFORMATION

Description	Package contents
HIT-RE 10 (19.6 fl. oz./580 ml)	Includes (1) cartridge with (1) mixer and filler tube
HIT-RE 10 (19.6 fl. oz./580 ml) MC	Includes (1) Master Carton with (12) cartridges with mixers and filler tube
HIT-RE 10 (19.6 fl. oz./580 ml) 18MC	Includes (18) Master Cartons with (12) cartridges each and mixers and filler tube
HIT-RE 10 (19.6 fl. oz./580 ml) (9MC) + HDM 500	Includes (9) master cartons with (12) cartridges each with (1) mixer and filler tube and (1) HDM 500 Manual dispenser
HIT-RE 10 (19.6 fl. oz./580 ml) (18MC) + HDM 500	Includes (18) master cartons with (12) cartridges each with mixers and filler tube and (1) HDM 500 Manual dispenser
HIT-RE 10 (19.6 fl. oz./580 ml) (18MC) + HDE 500	Includes (18) master cartons with (12) cartridges each with mixers and filler tube and (1) HDM 500 Battery dispenser



Hilti, Inc. (U.S.)
Legacy Tower, Suite 1000
7250 Dallas Parkway | Plano, TX 75024
www.facebook.com/HiltiNorthAmerica
www.hilti.com
Customer Service: 1-800-879-8000

Hilti (Canada) Corporation
2360 Meadowpine Blvd.
Mississauga, Ontario, L5N 6S2
www.facebook.com/HiltiNorthAmerica
www.hilti.ca
Customer Service: 1-800-363-4458